

# JCB WORKMAX

Brush Guard

PART # 100970

Hardware Kit: HK-099

## Kit Components:

Qty.	Part Description
1.....	Brush Guard Body
2.....	Light Guard
4.....	7/16"-14 x 1" Hex Flange Bolt
4.....	7/16"-14 Nylock Hex Flange Nut
8.....	3/8"-16 x 3/4" Hex Flange Bolt
8.....	3/8"-16 Nylock Hex Flange Nut

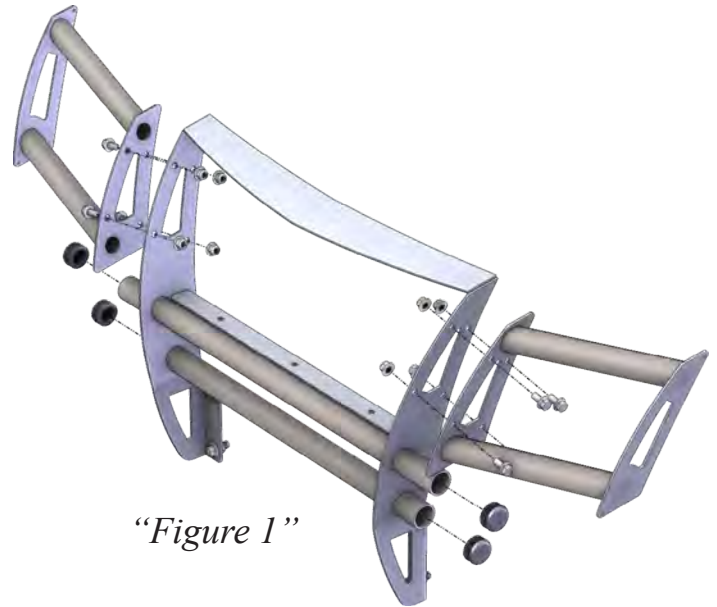

*"Figure 1"*

## INSTALLATION INSTRUCTIONS:

1. Install Left and Right Light Guards using the 3/8 Bolts and Nuts (A). See Figure 2.
2. Install the Tube Caps (B) as shown in Figure 2.
3. Install assembled Brush Guard to the machine using the 7/16 Bolts and Nuts (C) as shown in Figure 3.

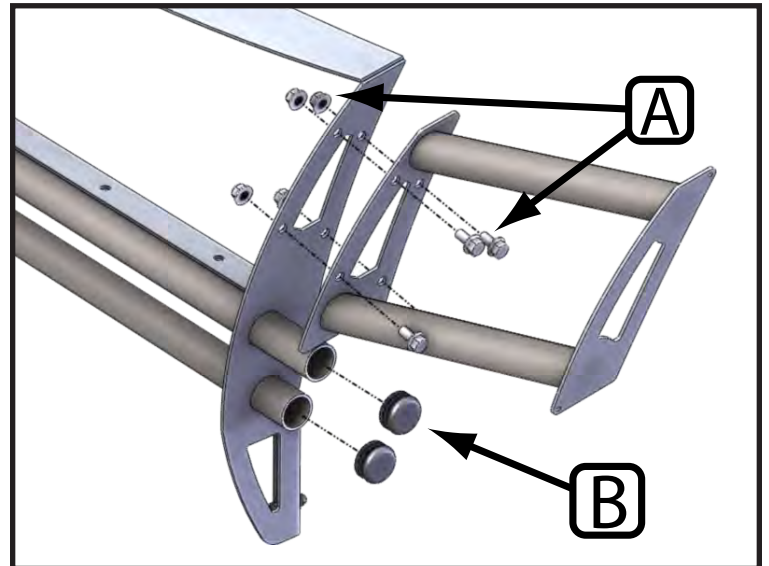

*"Figure 2" Light Guard & Tube Cap Install*



*"Figure 3" Brush Guard Install*