

# Polaris Ranger XP Midsize REAR BUMPER

Part #: 100990  
Hardware Kit: HK-034

**Contents:**

1x 100991 Ranger XP Midsize Bumper

**Hardware Kit:**

4x 3/8"-16 x 3/4" Shortneck Carriage Bolt  
4x 3/8"-16 x 1" Shortneck Carriage Bolt  
8x 3/8"-16 Hex Flange Nylock Nut  
4x 3/8" SAE Flat Washer  
2x 1/4" x 5/8L" Self-Tapping Screw  
4x Bumper Tube Caps

*Note: Additional hardware not required by this model may be included with the hardware kit.*

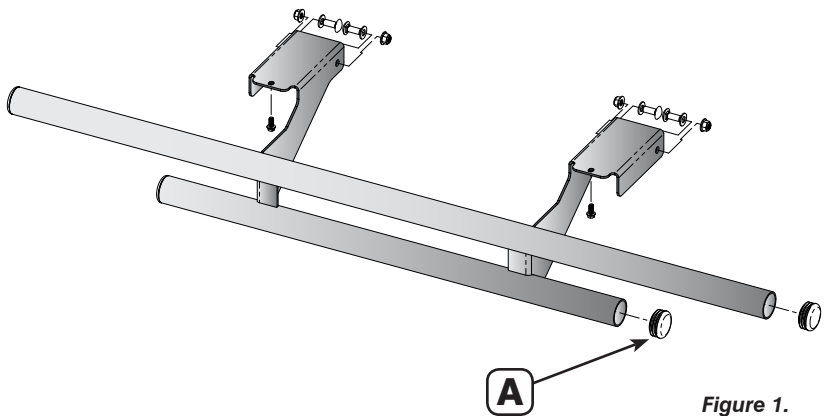

Figure 1.

**Installation:**

1. Assemble tube caps (A) to bumper tubes as shown in Figure 1.
2. Locate the OEM wiring harness under the rear most portion of the dump box.
3. Pull out two retaining clips (B) for the wiring harness; they are located towards the inside of the tubes labelled (C) in Figure 2. Pull out only the ones closest to each of the tubes labelled (C)!

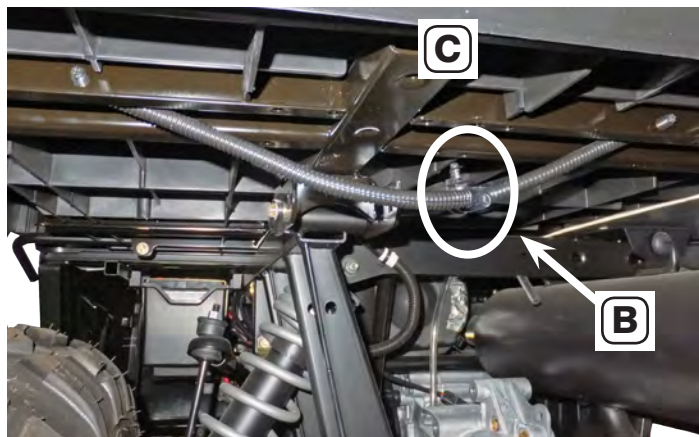

Figure 2. - Tube opposite is not shown.

4. Maneuver the bumper into position by sliding the brackets over top of the wiring harness and onto the frame mounts as shown in Figure 3.
5. Hold the bumper in place and run 4x 3/8"-16 x 1" carriage bolts through the square slots in the frame and holes in the bumper brackets (D). Bolt heads will be towards the inside of the bracket.



Figure 3.

6. Loosely fasten 3/8" washers and nuts as shown in Figures 1 & 3. Do not tighten.
7. Run 2x Self-Tapping screws up through slot (E) and into the box frame as shown in Figure 4. Turn until hand-tight only! Do not over-tighten or strip the hole.
8. Tighten all remaining hardware evenly.

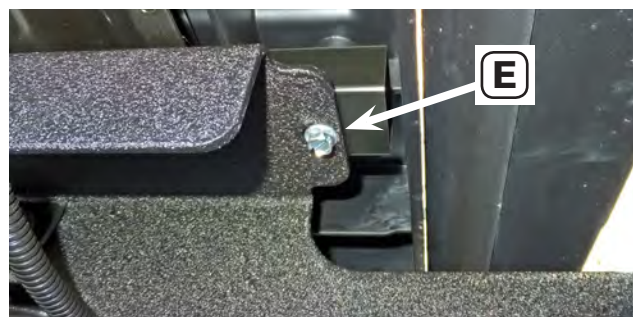

Figure 4.

