

POLARIS RANGER XP 900

Wide Winch Mount

Part #: 101024
 Hardware Kit: HK-305, HK-031

Contents:

- 1x 101021 Winch Mount Plate
- 1x 101023 Replacement Grill Wide

Hardware Kit:

- 3x 5/16"-18 x 1" Hex Flange Bolt
- 1x 5/16"-18 Hex Flange Nylock Nut
- 2x M10x1.50 x 25mm Hex Head Bolt
- 2x M10 Lock Washer
- 2x 3/8"-16 x 1.00" Carriage Bolt
- 2x 3/8"-16 Hex Flange Nylock Nut
- 1x HK-031 (UTV Mini-Rocker Hardware)
- 1x 22-18GA Spade Insulated Terminal

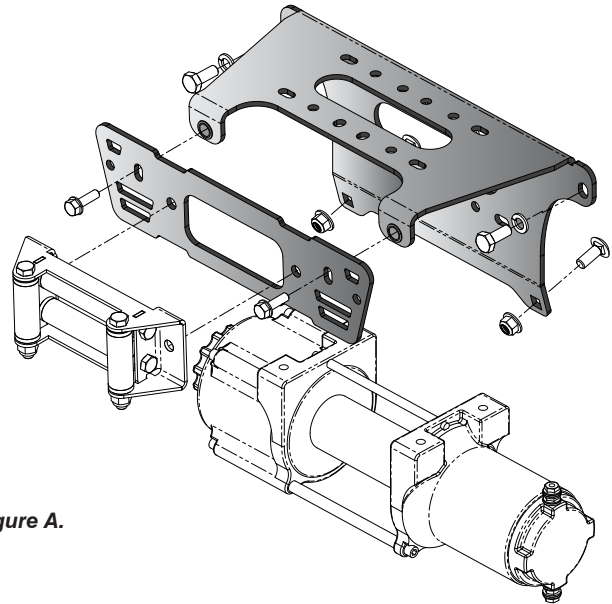

Figure A.

Installation:

Prepare Machine

1. Begin by turning machine off and disconnect the battery cables. Locate the battery compartment under the passenger or rear passenger seat. Lift bench seat up and pull out storage compartment. First remove the ground, then positive terminal.
2. Open the hood and find the recommended contactor location shown in **Figure 1**. Affix the contactor to recommended location. *

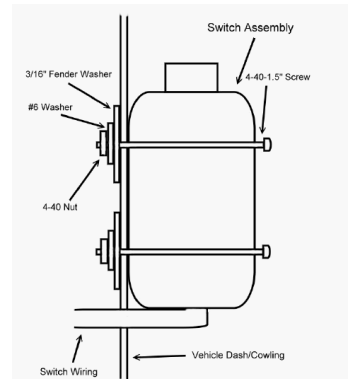

Figure 1.

* Note: This is the standard location for contactor with standard length winch wires; if your wires are too short, you can drill holes on the opposite side of the hood compartment and affix contactor as needed. Use caution when drilling holes, there is a radiator hose directly under this location.

3. Use included Mini-Rocker Switch Hardware Kit (HK-031) to fasten a handle bar mounted mini-rocker switch to the dash or any desired location.

- a. Remove handlebar mount hardware from the switch.
- b. Locate desired mounting location.
- c. Mark & drill 2 switch holes thru dash using switch housing as a template.
- d. Drill a 3rd hole for switch wiring.
- e. Assemble per **Figure 2**.



Optional Switch Mount Instructions*
 Figure 2.

Lead Rotation

4. For all wide winches with leads on the **end of the motor** in a **vertical** orientation, you will need to **rotate** the leads so they do not interfere with the bumper frame once re-assembled. If your winch has leads on the *inside* (near the spool), then move to Step 5, otherwise see **Figure 3** and continue.
- In general, to rotate the leads, loosen the two screws on the endcap in **Figure 3**, then rotate the entire motor housing 90 or 45 degrees (depending on your winch). For detailed instructions go to the **Support** section at www.kfiproducs.com and download "[Winch Motor Lead Rotation Instructions](#)".

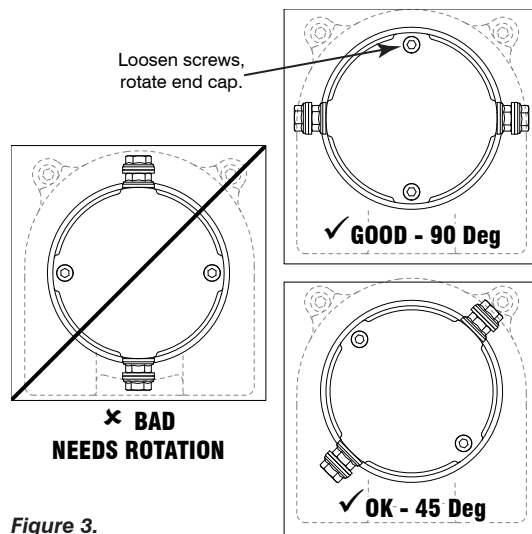

Figure 3.

Install Winch to Mount

- Connect the shortest wires (usually **RED & BLACK**) to the motor end of the winch per the **ALTERNATE WIRING DIAGRAM** shown in **Figure 15 (pg 4)**. Connect **BLACK** wire to **NEG(-) BLUE** winch post; connect **RED** wire to **POS(+)** **YELLOW** winch post.
- Assemble your winch to the mount plate as shown in **Figure 4**, using hardware included with your winch. *Most winches will be installed in the orientation shown in **Figure 4**, upside down with the clutch end on the passenger side of the machine and the motor to the driver's side once bolted to the machine.*

Wide Winch Assembled

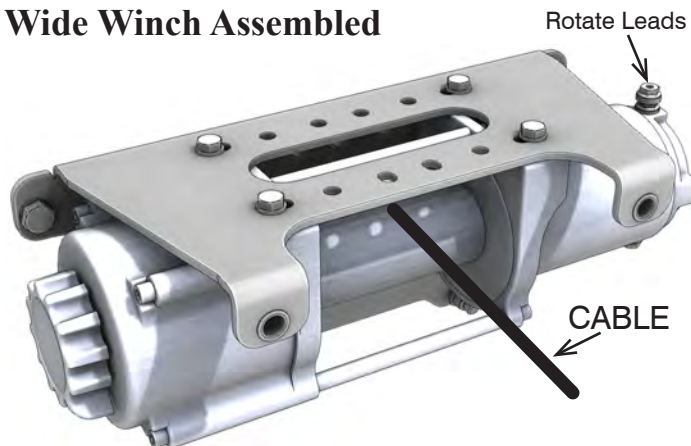
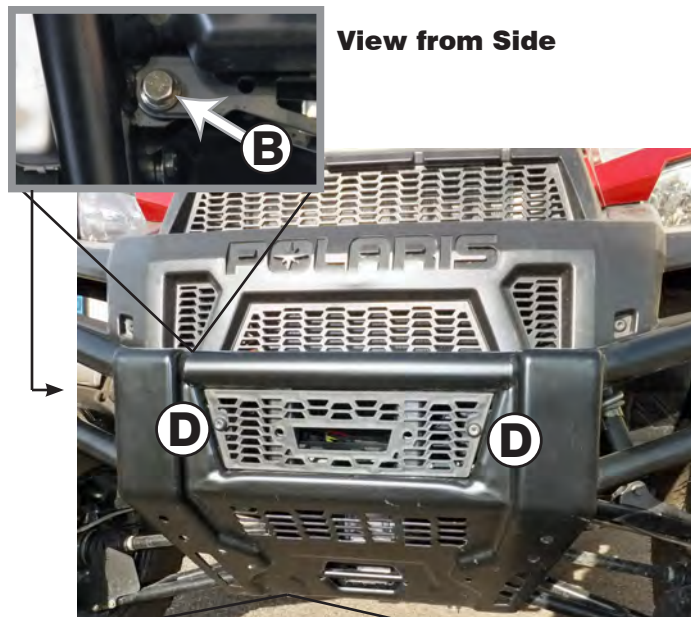

Figure 4.

Install Winch/Mount Assembly and Grill

- Remove the front bumper. Remove the 4 bolts attaching front bumper (B) and (C) as shown in **Figure 5**. See inset views. Remove OEM plastic grill from bumper frame held in place by 2 Torx head screws (D). Discard OEM grill.
- Install replacement grill to bumper as shown in **Figure 6** using original Torx screws (D).



Front

Figure 5.

Front Lower

- Install your fairlead to grill & bumper assembly as shown in **Figure 6**, using hardware provided with your winch. Pass bolts (X & Y) through fairlead, grill and bumper frame rails, then tighten.

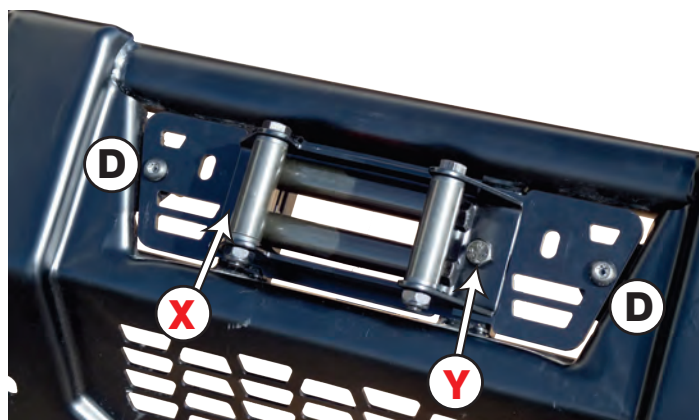

Figure 6.

- Lift assembled winch and mount into position on machine frame as shown in **Figure 7**. Fasten to frame using two M10 bolts & lock washers at positions (E) and two 3/8" carriage bolts & flange nuts at positions (F). Loosely start the top bolts first to make install easier. Install carriage bolts (F) with the head to the rear of the frame and nut on the front side with the mount plate as shown in **Figure 7 (pg3)** and **Figure A (pg1)**. Tighten all hardware evenly.
- Re-assemble bumper to frame using bolts removed in step 7. Loosely affix nuts to bolts allowing for final adjustment of grill to mount plate. Fasten grill

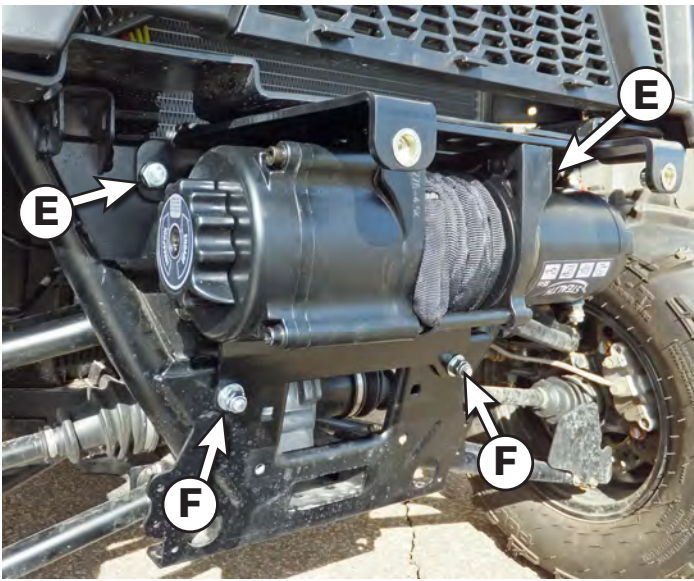

Figure 7.

to mount using two 5/16" Flange Bolts included in hardware kit (See Figure A, pg1). Evenly tighten all mount and frame hardware.

Route Wires

12. If you have a Crew model, you will need to use the extended 11" cables included with the Crew Kit (KFI#: UTV-WEK)

Locate starter solenoid next to battery as shown in Figure 8. Using the ALTERNATE WIRING DIAGRAM (Figure 15, pg4) as a guide, attach the **YELLOW POS(+)** wire to the battery fed solenoid as shown in Figures 8 and 9. Then, attach the **BLUE NEG(-)** wire to the ground post as shown in Figure 9.

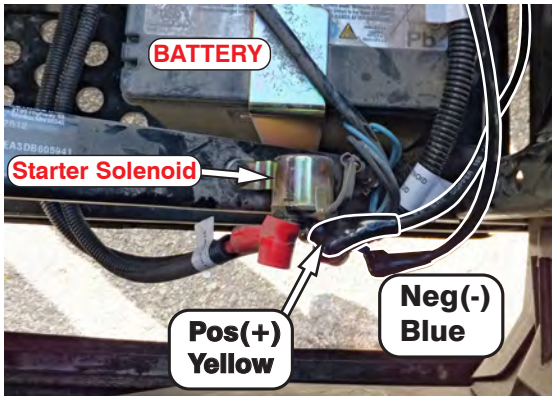

Figure 8.

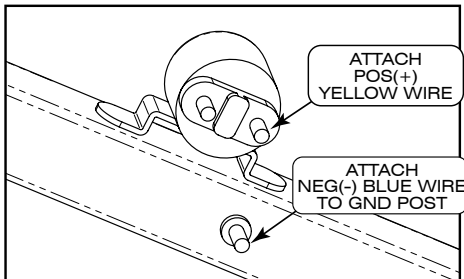

Figure 9.

13. Remove plastic shroud covering center floor console by taking out the the 4 plastic rivets (A) shown in Figure 10. Route the longest wires (usually **BLUE & YELLOW**) included with your winch from the battery to the contactor location by passing through the opening to the battery compartment and through the front foot well as shown in Figure 11.

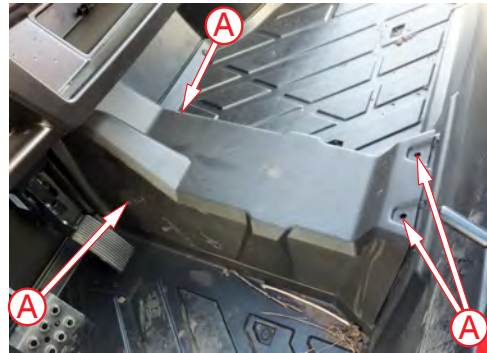

Figure 10.

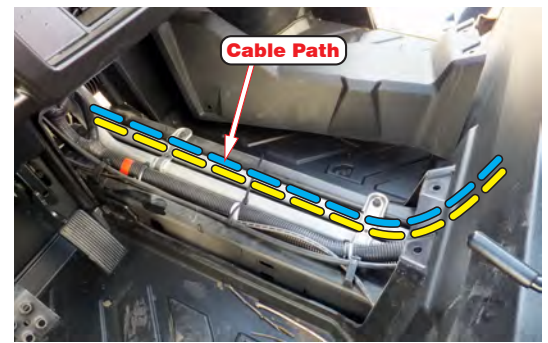

Figure 11.

13. Finish routing longest wires up along frame and through outlet noted in Figures 1 (pg1) and 12. Do **NOT** connect wires to contactor at this time.

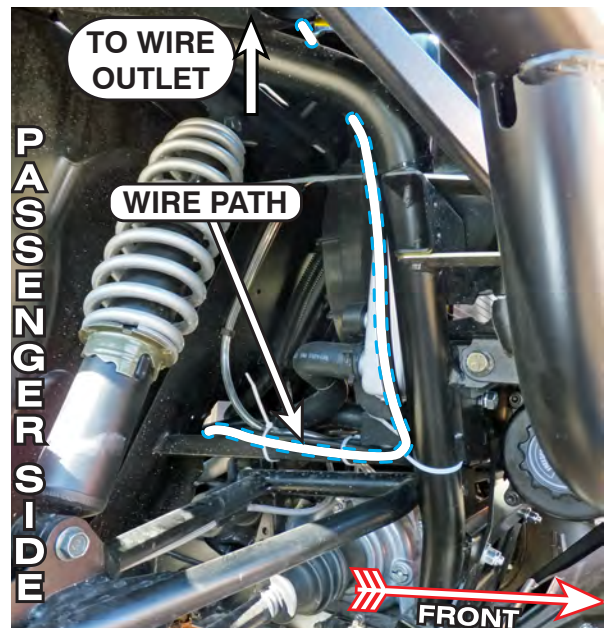

Figure 12.

15. Route wires from winch motor end to the contactor location (**Figure 1 pg1**) by running them in front of the radiator. Do **NOT** connect wires to contactor at this time.
16. Route switch wiring behind front dash and through a wiring grommet located behind the glove box. See grommet (G) located in **Figure 13**. You may remove the top access panel (H) to aid in routing and securing wiring.

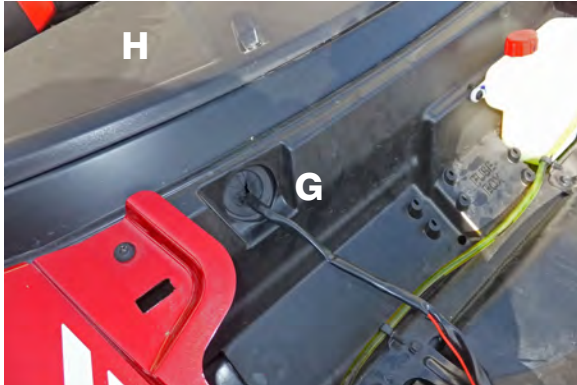

Figure 13.

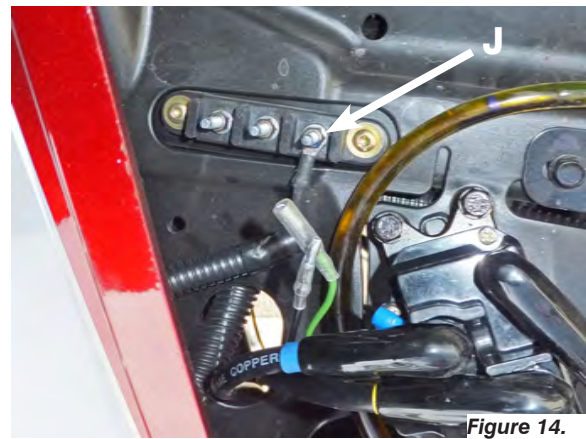

Figure 14.

Finalize Wiring

17. Attach the ignition fed wire (RED) from your switch to the post labelled (J) in **Figure 14**, using the 22-18GA Spade Insulated Terminal included in the winch mount hardware kit.
18. Connect wire to contactor according to **ALTERNATE WINCH WIRING DIAGRAM** shown in **Figure 15**.
19. **Secure all wires, reconnect battery positive & ground cable, and replace access panels and shrouds removed in steps 1, 2, and 13.**

ALTERNATE WINCH WIRING DIAGRAM

Figure 15.

