

POLARIS RANGER 900 XP

2" Receiver Mount PART # 101080
Hardware Kit: HK-305, HK-031

Kit Components:

Qty.	Part Description
1.....	Receiver Plate (101081)
1.....	Receiver Grill Plate (101085)
3.....	5/16"-18 x 1" Hex Flange Bolt (1 NOT USED)
1.....	5/16"-18 Nylock Flange Nut (NOT USED)
2.....	M10-1.5 x 25mm Hex Bolt
2.....	M10-1.5 Lock Washer
2.....	3/8"-16 x 1" Shortneck Carriage Bolt
2.....	3/8"-16 Nylock Flange Nut
1.....	Spade Terminal (NOT USED)
1.....	M10x1.50 x 35mm Hex Head Bolt (NOT USED)
1.....	M10x1.50 Hex Nut (NOT USED)
1.....	UTV Mini Rocker Hardware Kit (HK-031)

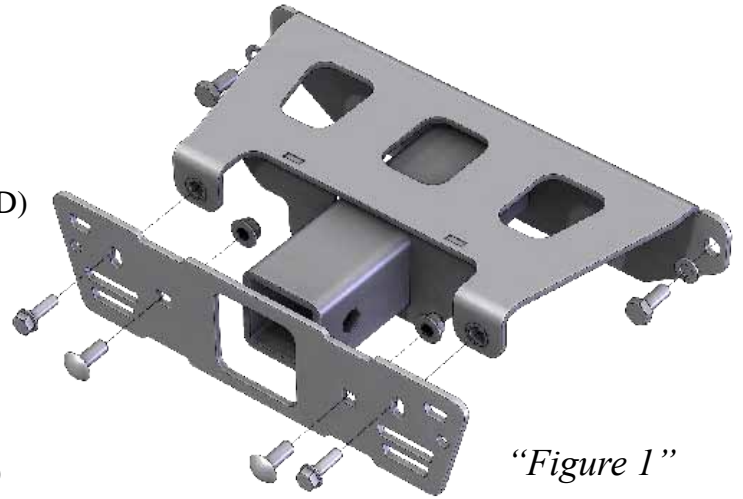

"Figure 1"

INSTALLATION INSTRUCTIONS:

1. Take off the front bumper by removing 4 Bolts (A) as shown in Figure 2.
2. Mount the Receiver Plate to the frame using pre-threaded holes (B) and M10 Bolts and Lock washers (C) supplied in the hardware kit.

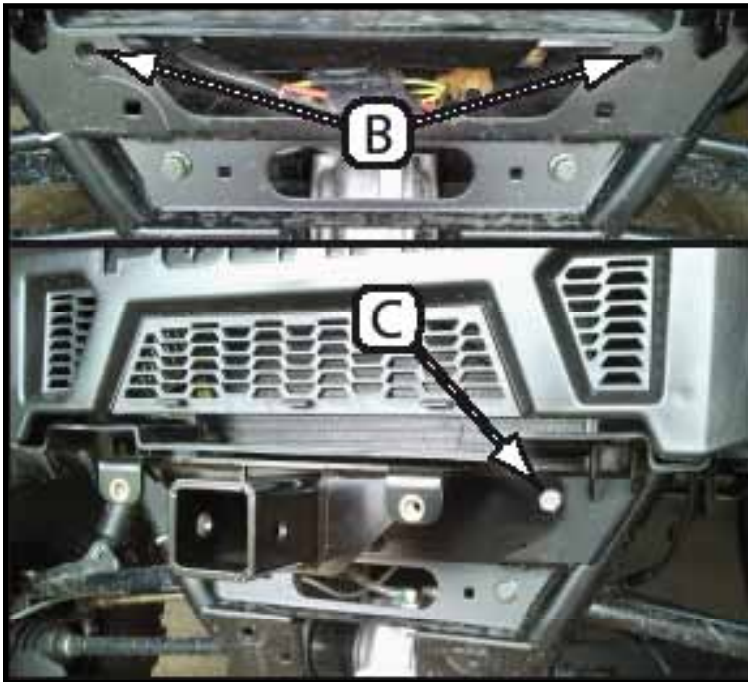

"Figure 3" Receiver Plate Install

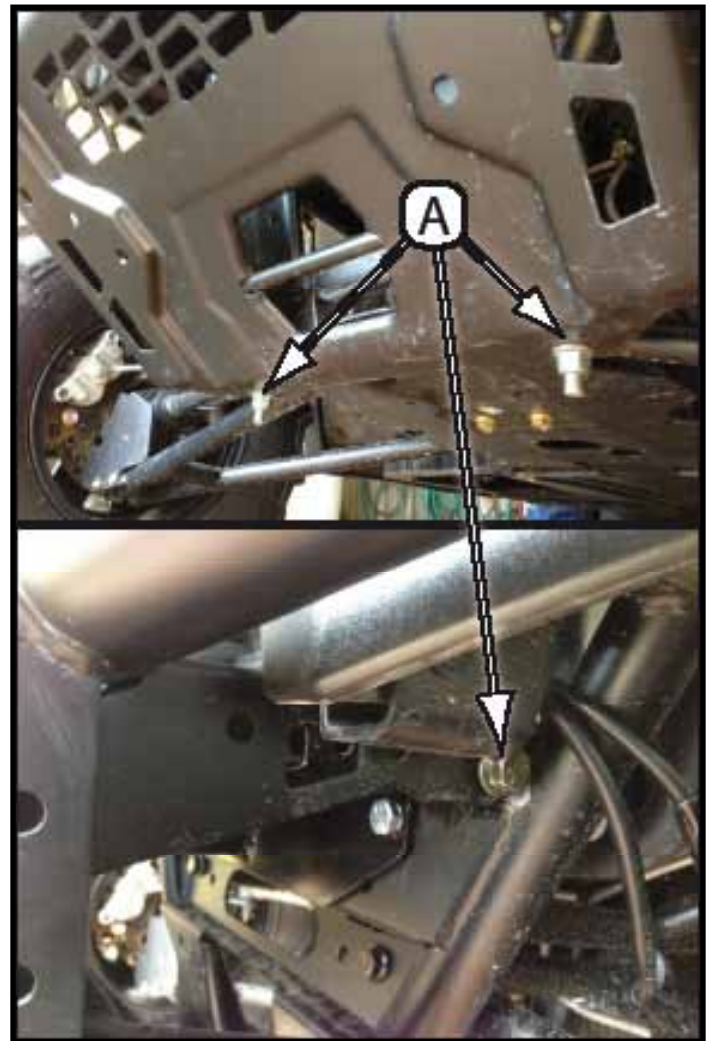

"Figure 2" Bumper Removal

3. Remove grill from bumper as shown in Figure 4. Retain screws (D) to reuse later.

4. Loosely reinstall bumper as removed in Step 1.

Note: make sure to leave the bolts loose as you may need to be able to move the bumper around in order to line up all the bolts in the next step.

5. Loosely install Receiver Grill Plate to bumper using the screws (D) removed in Step 3. See Figure 5.

6. Loosely install Receiver Grill Plate to the Receiver Plate using the 5/16" Flange Bolts (E) and install Carriage bolts and 3/8" nuts to location (F) through the holes on the bumper as shown in Figure 1,5.

Note: you may need to move the bumper around in order to get them to line up.

7. Tighten all bolts.



“Figure 4” Bumper Grill Removal

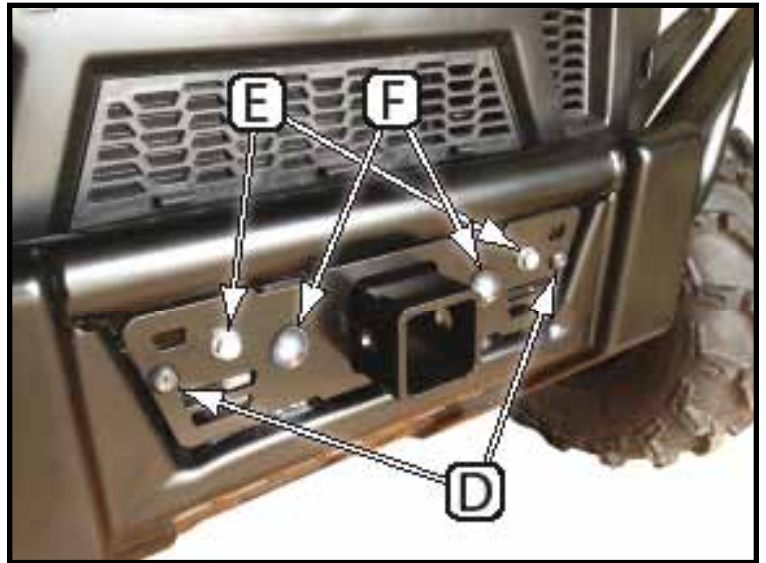

“Figure 5” Receiver Grill Install

