

# Polaris Ranger XP 900/570 Full Size/Diesel REAR BUMPER

Part #: **101090**  
Hardware Kit: **HK-001 (2X)**

Contents:

1x 101091 Ranger Bumper  
2x 101094 Bumper Hanger

Hardware Kit (Total):

8x 5/16"-18 x 1" Hex Flange Bolt  
8x 5/16"-18 Nylock Nut  
4x Bumper Tube Caps

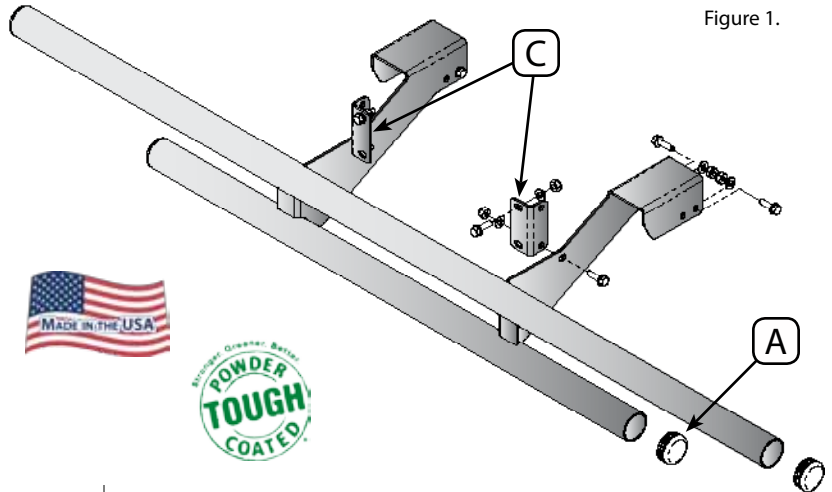

Figure 1.

## Installation:

1. Assemble tube caps (A) to bumper tubes as shown in [Figure 1](#).
2. Locate the strip with square cutouts (B) shown in [Figure 2](#) at the rear of the dump box
3. Position each of the Hanger Brackets (C) according to diagrams shown in [Figures 1&3](#). Loosely bolt to rear of strip using 2x 5-16"-18 Hex Flange Bolts (D), and nuts as seen in [Figure 2](#).
4. Position bumper over frame mounts as shown in [Figure 4](#).

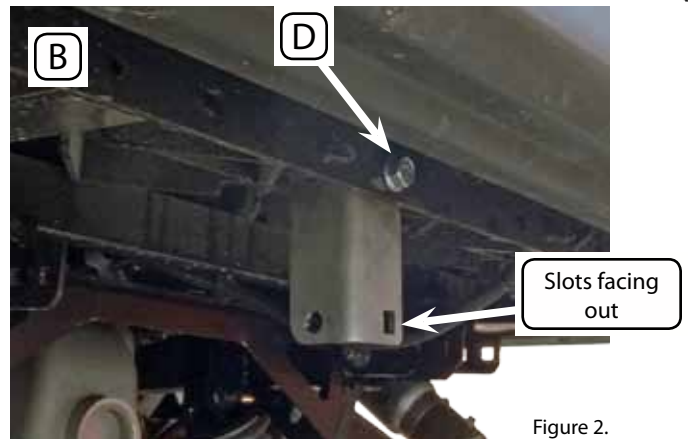

Figure 2.

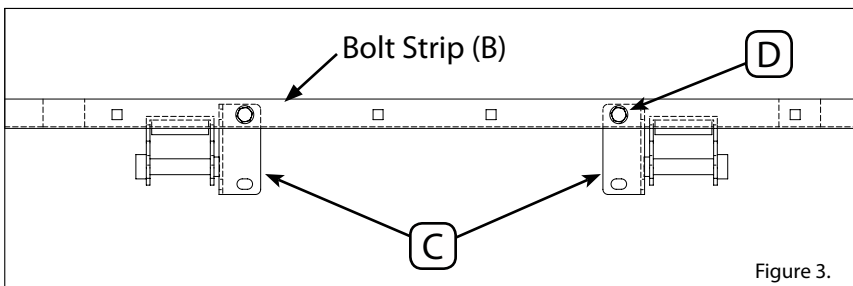

Figure 3.

5. Hold the bumper in place and run 4x 5/16"-18 x 1" Hex Flange Bolts (D) through holes in bumper and frame as shown in [Figure 4](#).

Loosely affix nuts. *Bolt only through the holes farthest away from the tailgate, labeled (E) in [Figure 4](#).*

6. Rotate bumper assembly up and into alignment with Hanger Brackets previously installed as seen in [Figure 1&4](#).
7. Bolt Bumper to Hanger Brackets using 2x 5/16"-18 Hex Flange Bolts, and nuts (D).
8. Evenly tighten all hardware..

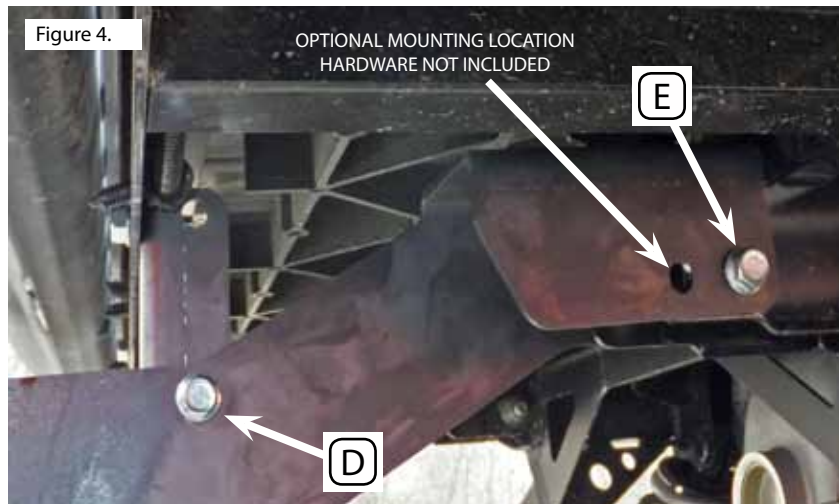

Figure 4.