

POLARIS RZR XP 1000

Winch Mount PART # 101174
 Hardware Kit: HK-034, HK-031

Kit Components:

Qty.	Part Description
1.....	Winch Mount Plate (101171)
1.....	Wide Fairlead Plate (101173)
4.....	3/8"-16 x 3/4" Shortneck Carriage Bolt
4.....	3/8"-16 x 1" Shortneck Carriage Bolt
8.....	3/8"-16 Flanged Nylock Hex Nut
4.....	3/8" SAE Flat Washer (2 Used)
1.....	UTV Mini Rocker Kit (HK-031)
2.....	1/4"-20 x 5/8" Hex Flanged Self Tapping Screw (Not Used)

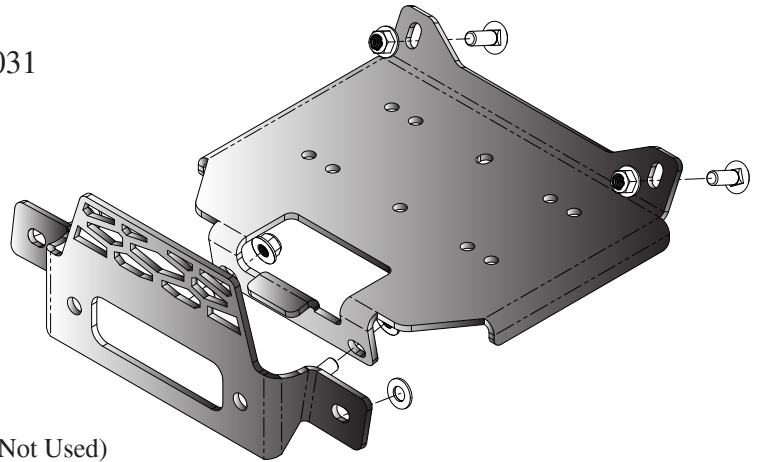

“Figure 1”

INSTALLATION INSTRUCTIONS:

1. Remove the hood. (See Figure 2)
2. Take off the access cover by removing the 2 bolts (A) as shown in Figure 3.
3. Detach front fascia by removing the 10 Torx Bolts (B) as shown in Figure 4.

Note: Be sure to detach the head lights from their wiring before pulling front fascia off the machine.

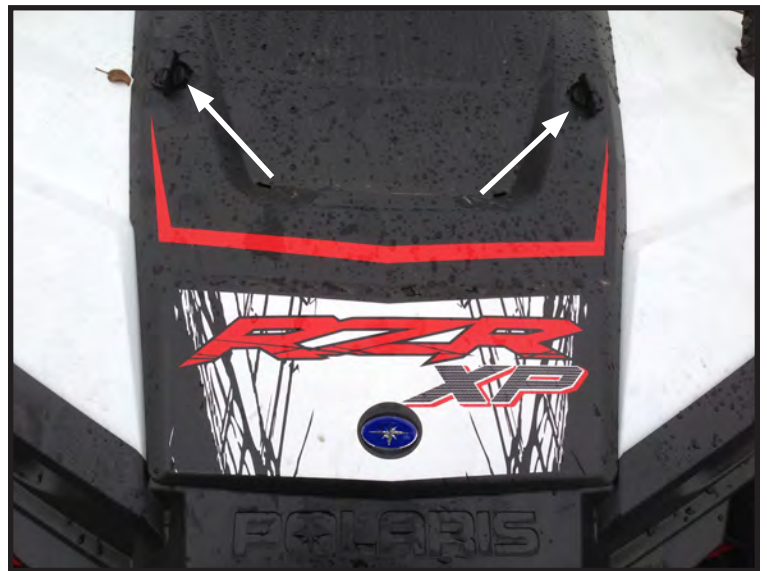

“Figure 2” Hood Removal

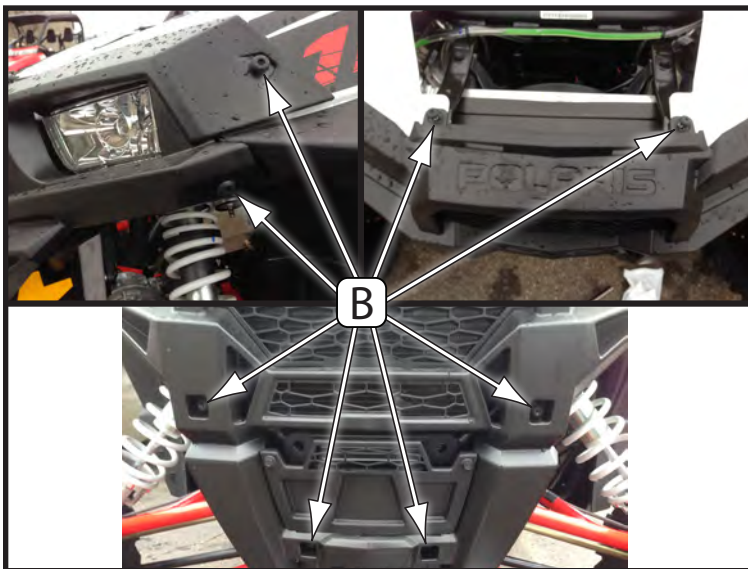

“Figure 4” Front Fascia Removal

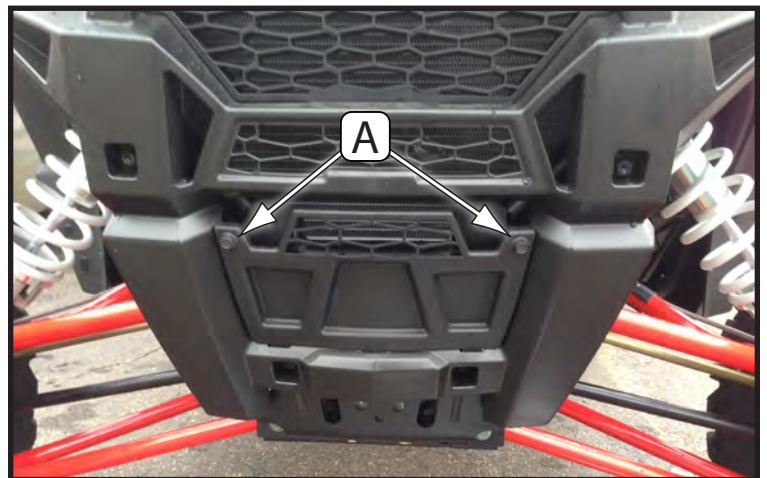

“Figure 3” Access Cover Removal

Note: When installing your wide winch (hole pattern 6.6 inches) you will need to grind away some of the frame in the front and rear of the winch cable holes as shown in Figure 5. The front hole needs to have at least a 1/16th" taken off each side and the rear hole needs to have at least a 1/4" taken off each side.

If installing a wide synthetic cable winch you MUST grind the frame; however, if installing a wide steel cable winch it is up to you if you grind or not (winch cable will rub if not ground).

- Place mount into position from the drivers side of the machine (Figure 7) in order to avoid the breather hose for the front differential. Align the mount with the bolt holes as shown in Figure 6 (C&D). Fasten mount to the front frame rail using the 3/8" x 1" Carriage Bolts and Nuts (F), with nuts to the inside so the carriage bolts sit in the square cutout. Use the 3/8" x 3/4" Carriage Bolts and Nuts (E) with the bolt head inside the frame channel, for the rear holes. Tighten all bolts.

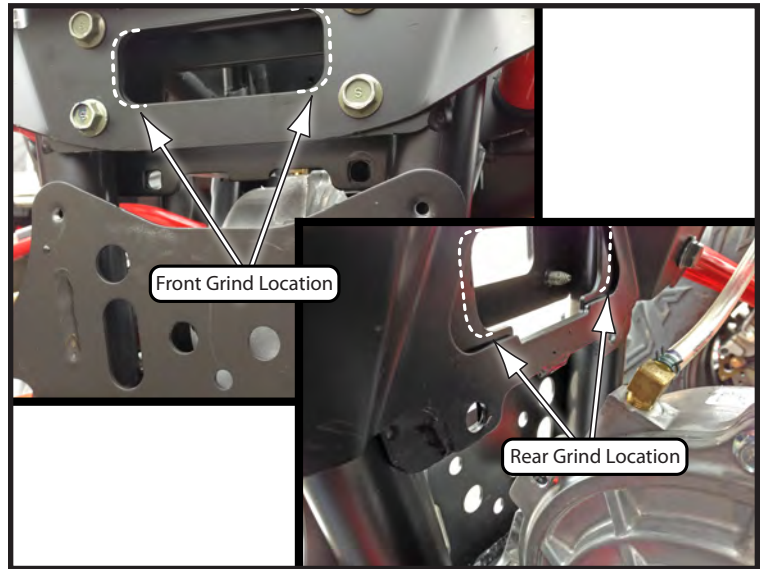

"Figure 5" Wide Winch Frame Modification

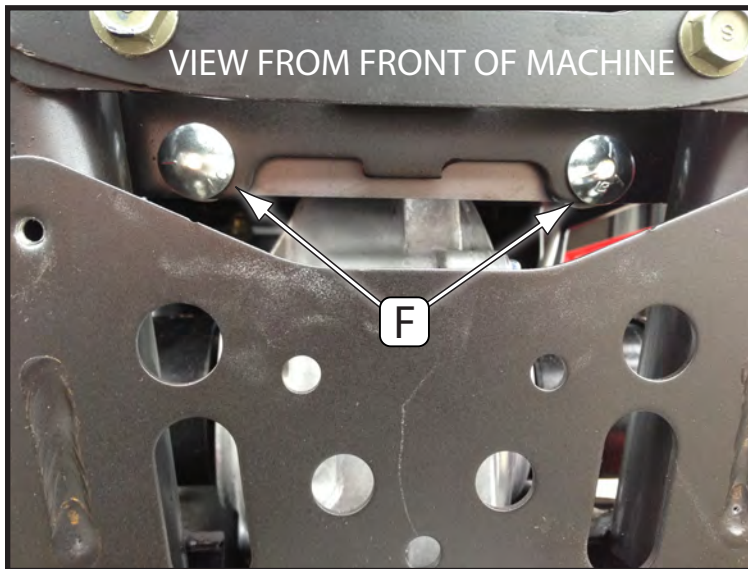

"Figure 8" Front Bolts for Mount

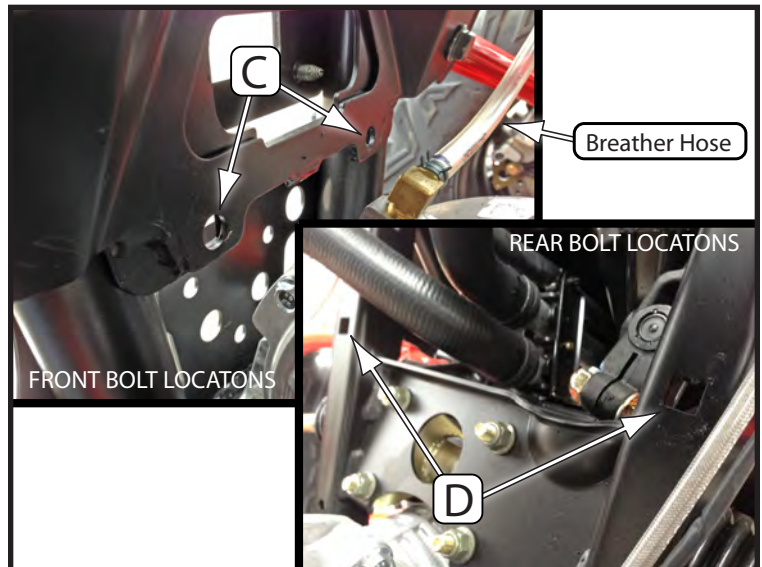

"Figure 6" Winch Mount Bolt Locations

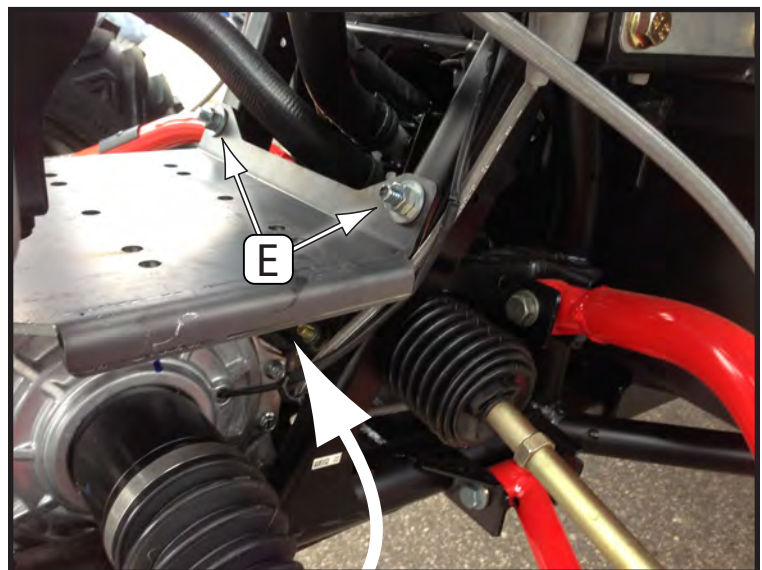

"Figure 7" Winch Mount Install

5. Install your winch to the mount using the hardware provided with your winch as shown in Figure 10.

Note: Figure 9 shows the winch hole pattern for mounting your wide winch. You will also have to maneuver the winch under the radiator hoses that are there. These hoses are designed to fit around the winch.

6. Install your roller fairlead or hawse to the fairlead plate as shown in Figure 11 using the hardware provided with your winch.
7. Install the fairlead assembly by removing the nuts (G) from the upper A-arms. (Do not remove the A-arm bolts) Place ONE 3/8" Washer over each bolt, then the fairlead assembly over the bolts and washers and replace the nuts.
8. Tighten all hardware.
9. Replace front fascia and hood removed in steps 1&3, replace all torx bolts and tighten. Reconnect headlight wires.
10. See page 4 for wiring specs.

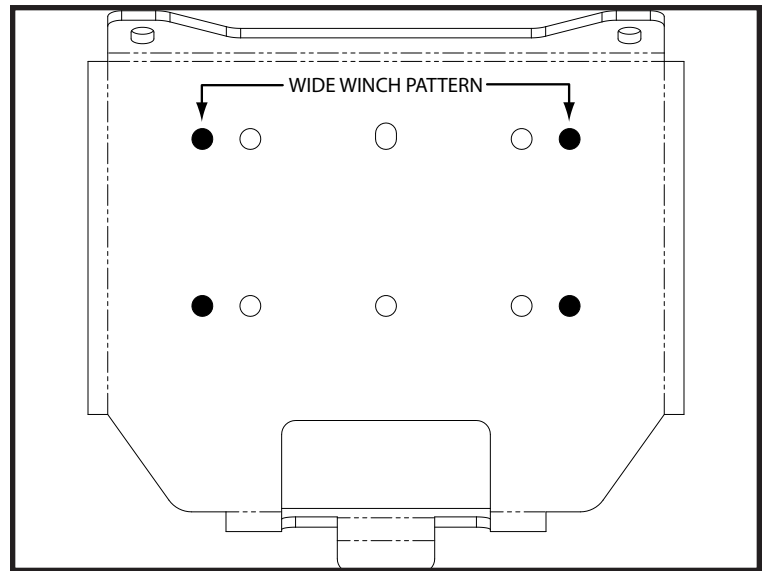

“Figure 9” Mount Hole Pattern

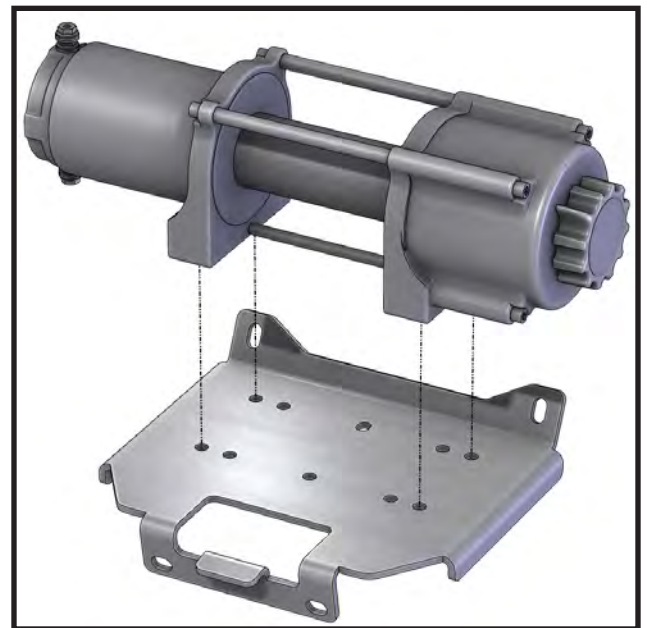

“Figure 10” Winch Install

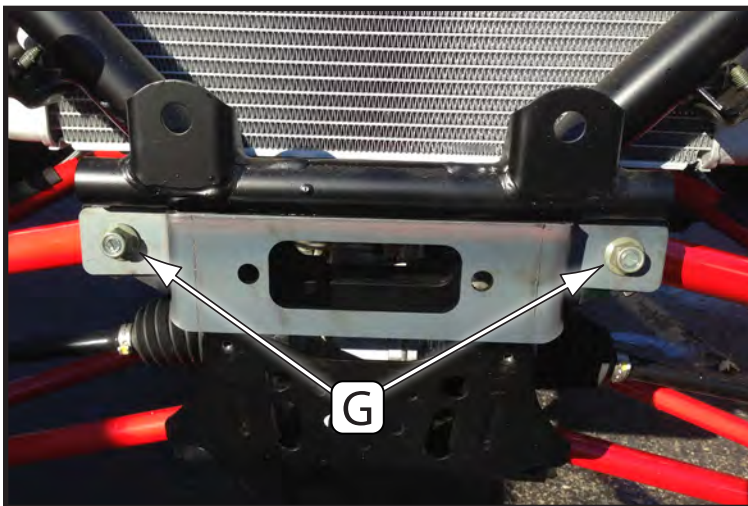

“Figure 12” Fairlead Bracket Install

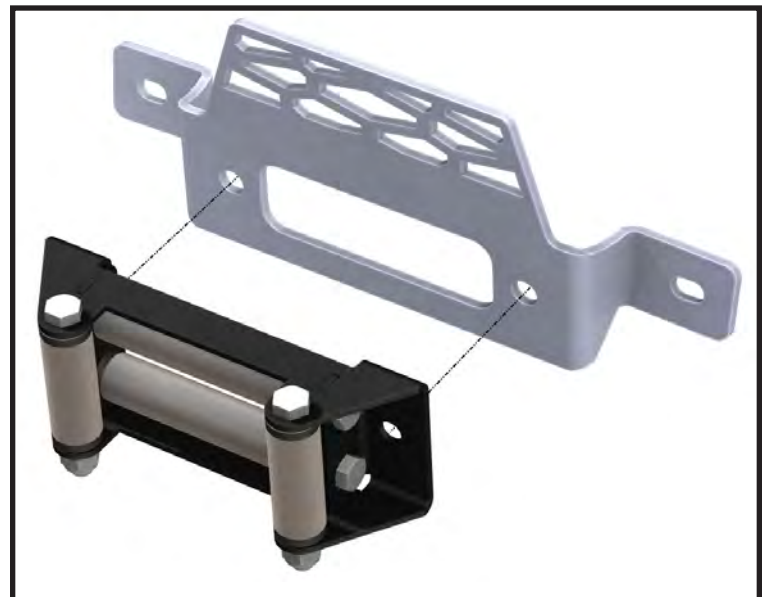

“Figure 11” Roller Fairlead Install

WIRING INFORMATION

1. For contactor location please see “Figure 13”. There is no set location for the contactor on this machine. *We suggest placing it some where under the hood that is out of the elements.*
2. *The wires will need to be switched for this machine. The longer wires (Blue/Yellow) will be used to go from the battery to the contactor. The shorter wires (Black/Red) will be used to go from the winch to the contactor. See Figure 17 on Page 5.*
3. Mini-Rocker Switch Hardware kit. This allows you to mount your usual handle bar mounted switch to almost any desired location.
 - a. Remove handlebar mount hardware from the switch.
 - b. Locate desired mounting location
 - c. Mark and drill two switch holes through dash using switch housing as a template
 - d. Drill a 3rd hole for the switch wiring.
 - e. Assemble per Figure 16.
4. Find a location that suits your purposes for the mini-rocker switch and hand remote.
5. Wire the red ignition wires from controllers to the acc post (+) as shown in Figure 15.

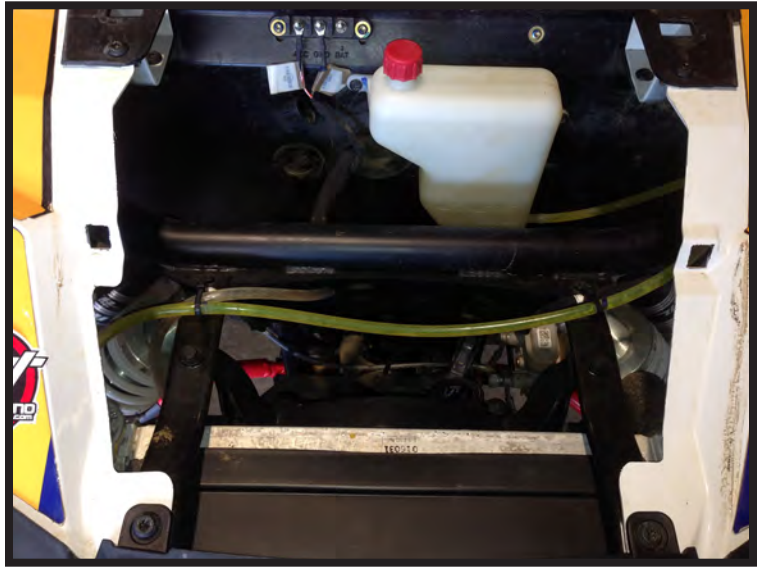

“Figure 13” Contactor Location
(Located under the hood.)



“Figure 14” Battery Location
(Battery is located under driver seat.)

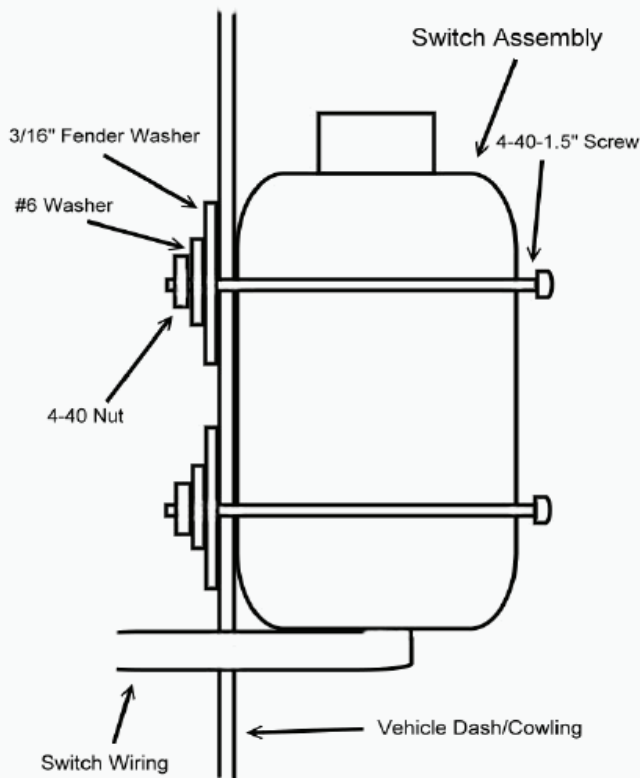

Optional Switch Mount Instructions*

“Figure 16” Mini-Rocker Mounting

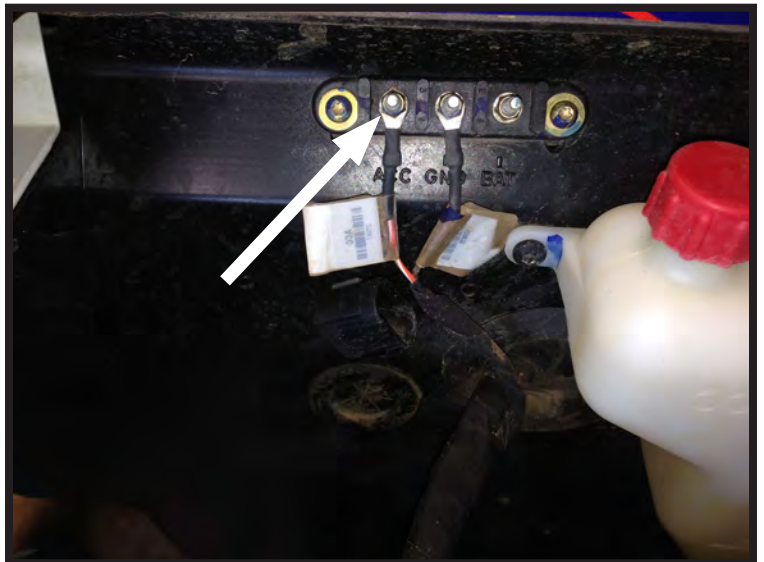

“Figure 15” Wire Location
(Located under the hood.)

ALTERNATE WINCH WIRING DIAGRAM

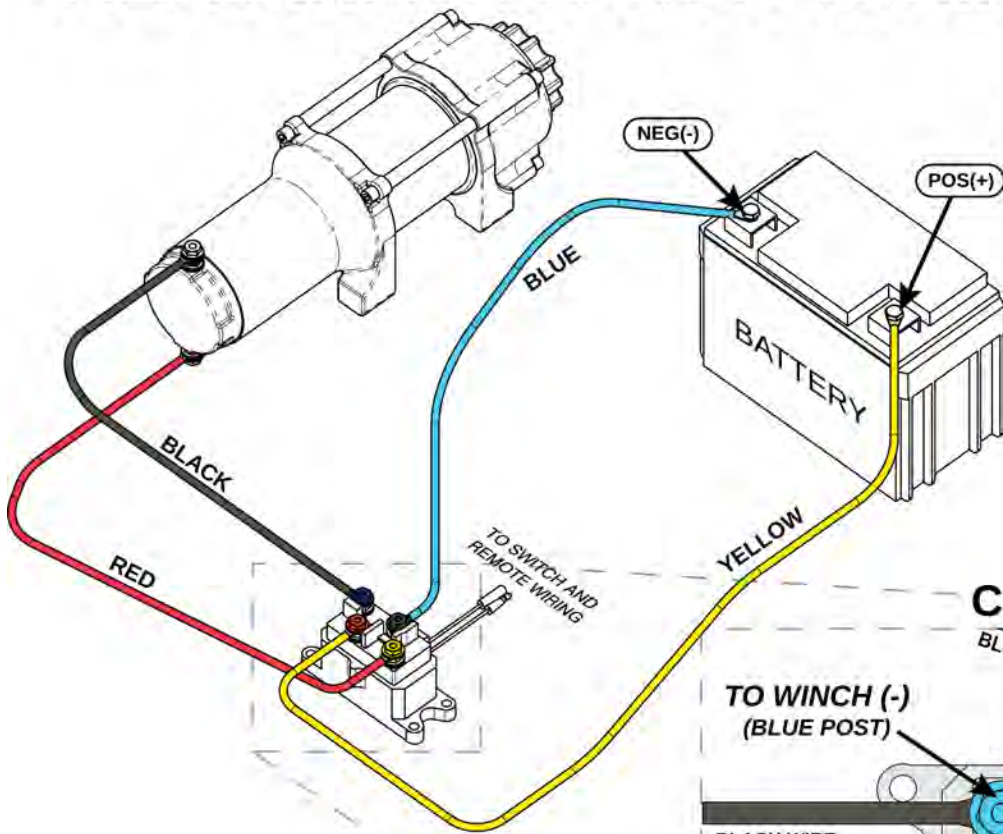

* For use with ATV/UTV applications where contactor cannot be located close to vehicle battery.

* Run shortest wires, usually red & black from contactor to winch; run longest wires, usually blue & yellow from contactor to battery.

⚠ CAUTION ⚠
 These two posts must be wired to the battery!

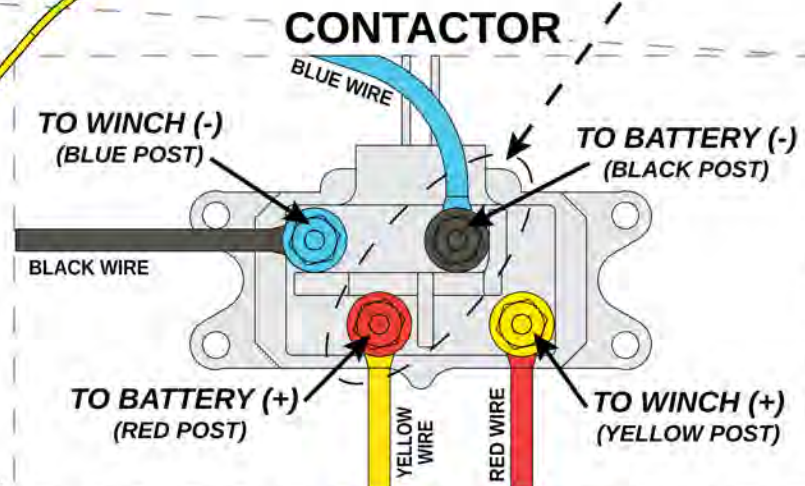

⚠ CAUTION ⚠
 FAILURE TO FOLLOW WIRING DIRECTIONS AS SHOWN MAY RESULT IN DAMAGE TO YOUR WIRING SYSTEM OR EQUIPMENT.

- WIRE WINCH NEGATIVE (BLACK WIRE) TO --> BLUE CONTACTOR POST
- WIRE WINCH POSITIVE (RED WIRE) TO --> YELLOW CONTACTOR POST
- WIRE BATTERY NEGATIVE (BLUE WIRE) TO --> BLACK CONTACTOR POST
- WIRE BATTERY POSITIVE (YELLOW WIRE) TO --> RED CONTACTOR POST

“Figure 17” Alternate Wiring Diagram