

POLARIS RZR 900/1000/GENERAL

Winch Mount

PART # 101220

Hardware Kit: HK-034, HK-031, HK-318

Kit Components:

Qty.	Part Description
1.....	Winch Mount Plate (101223)
1.....	Standard Fairlead Plate (101221)
4.....	3/8"-16 x 3/4" Shortneck Carriage Bolt (Not Used)
4.....	3/8"-16 x 1" Shortneck Carriage Bolt
8.....	3/8"-16 Flanged Nylock Hex Nut
4.....	3/8" SAE Flat Washer (2 Used)
1.....	UTV Mini Rocker Kit (HK-031)
2.....	1/4"-20 x 5/8" Hex Flanged Self Tapping Screw (Not Used)
2.....	3/8"-16 x 1-1/2" Hex Flanged Bolt (RZR 1000)
12.....	3/8" USS Flat Washer (RZR 1000)

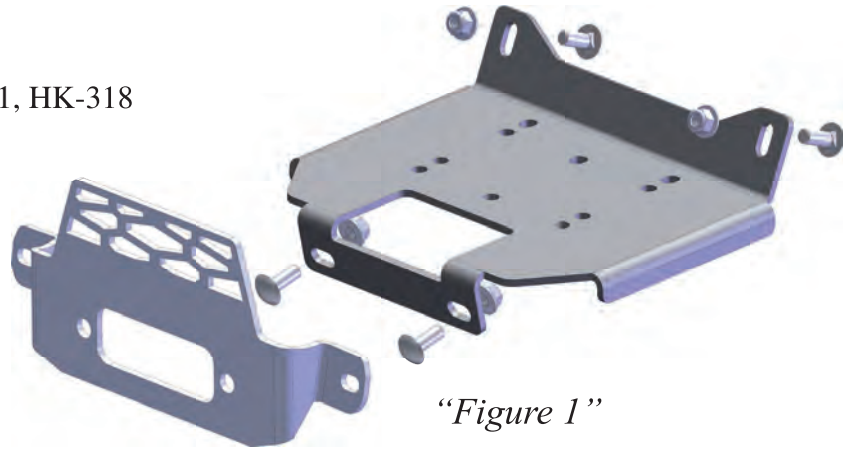

“Figure 1”

INSTALLATION INSTRUCTIONS:

POLARIS GENERAL: START ON STEP 4

1. Remove the hood. (See Figure 2)
2. Take off the access cover by removing the 2 bolts (A) as shown in Figure 3.
3. Detach front fascia by removing the 10 Torx Bolts (B) as shown in Figure 4.

Note: Be sure to detach the head lights from their wiring before pulling front fascia off the machine.

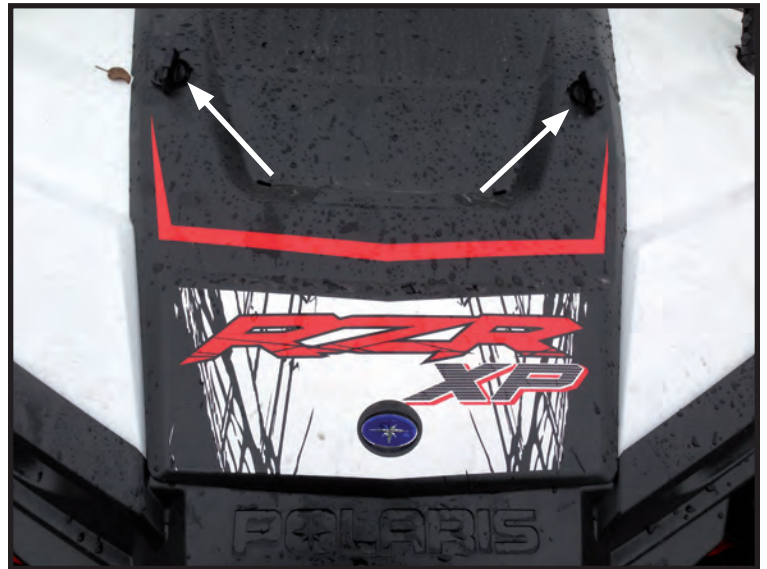

“Figure 2” Hood Removal

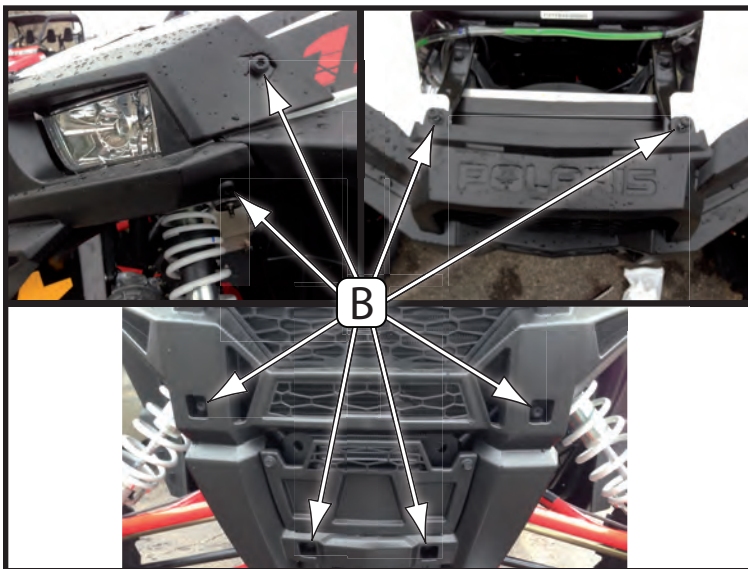

“Figure 4” Front Fascia Removal

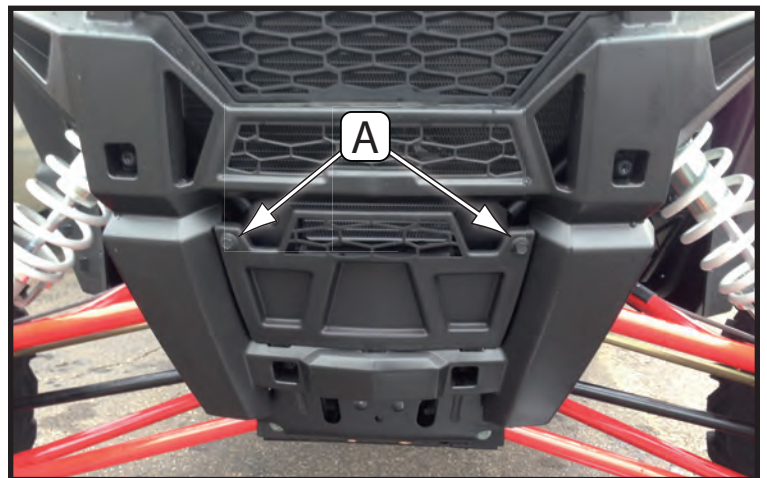

“Figure 3” Access Cover Removal

- Place mount into position from the drivers side of the machine in order to avoid the breather hose for the front differential. Align the mount with the bolt holes as shown in Figure 5 (C&D). Fasten mount to the front frame rail using the 3/8" x 1" Carriage Bolts and Nuts (F), with nuts to the inside so the carriage bolts sit in the square cutout. Use the 3/8" x 1" Carriage Bolts and Nuts (E) with the bolt head inside the frame channel, for the rear holes. Get all hardware started loosely, then evenly tighten the four nuts. If there is space between the frame and winch mount, refer to page 4 and use the spacer kit. Depending on where the winch sits (too close on front or back side) you may need to place washers in front or behind the mount plate to move the winch and mount forward or back to provide the clearance needed. If there is no space between the mount and frame move on to step 5.

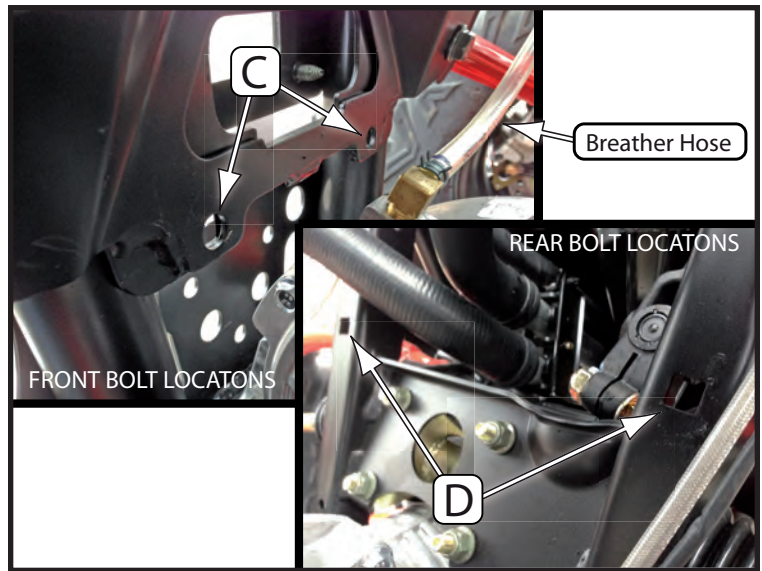

“Figure 5” Winch Mount Bolt Locations

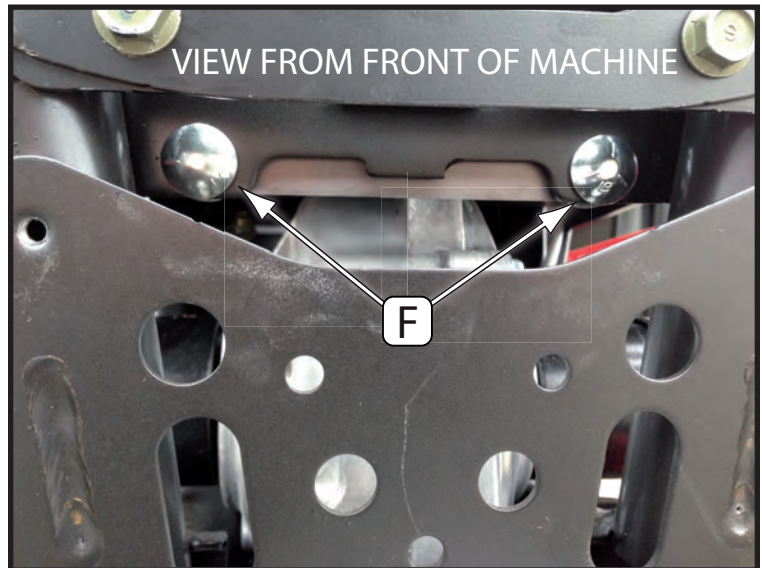

“Figure 6” Front Bolts for Mount

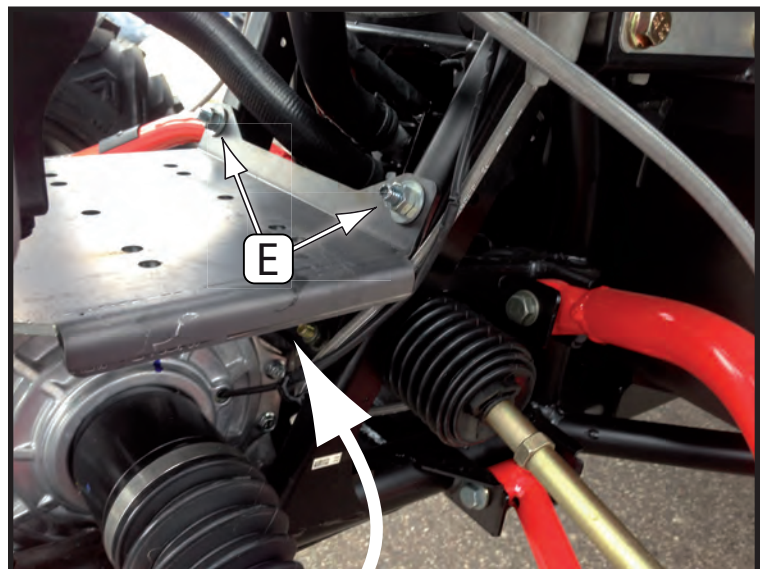

“Figure 7” Winch Mount Install

5. Install your winch to the mount using the hardware provided with your winch as shown in Figure 8.
6. Install your roller fairlead or hawse to the fairlead plate as shown in Figure 9 using the hardware provided with your winch. GENERAL 1000: install fairlead plate first, then the roller fairlead to the plate.
7. Install the fairlead assembly by removing the nuts (G) and washers from the upper A-arms. (Do not remove the A-arm bolts) Place the fairlead assembly over the bolts and replace the nuts.
8. Tighten all hardware.
9. Replace front fascia and hood removed in steps 1&3, replace all torx bolts and tighten. Reconnect headlight wires.
10. Use the instructions provided with your winch, wire accordingly.

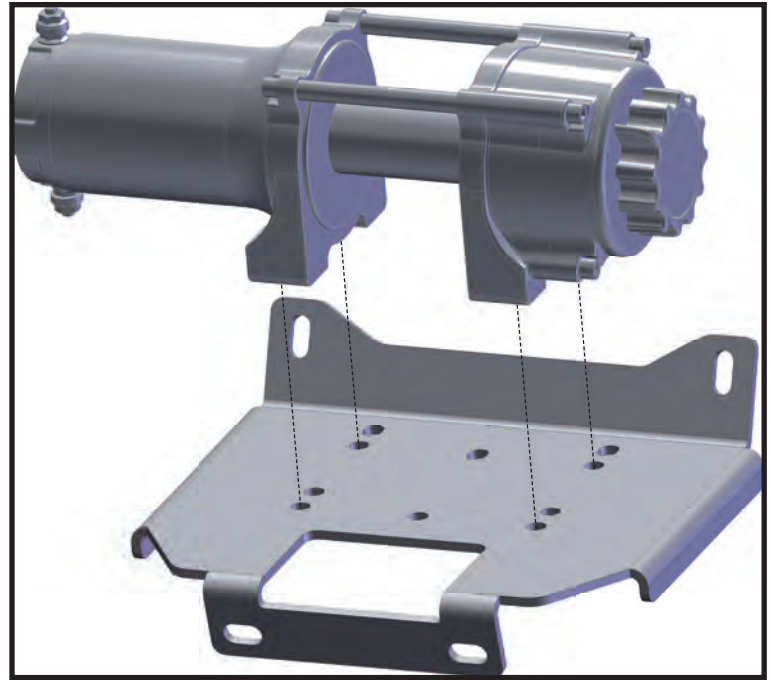

“Figure 8” Winch Install

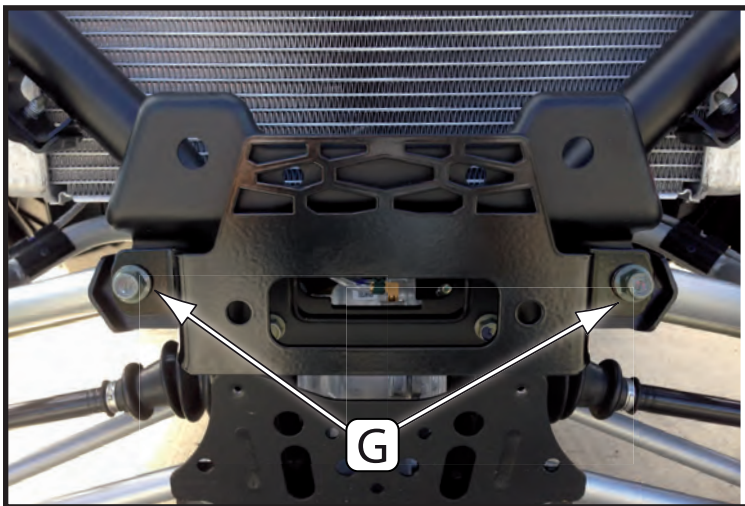

“Figure 10” Fairlead Bracket Install

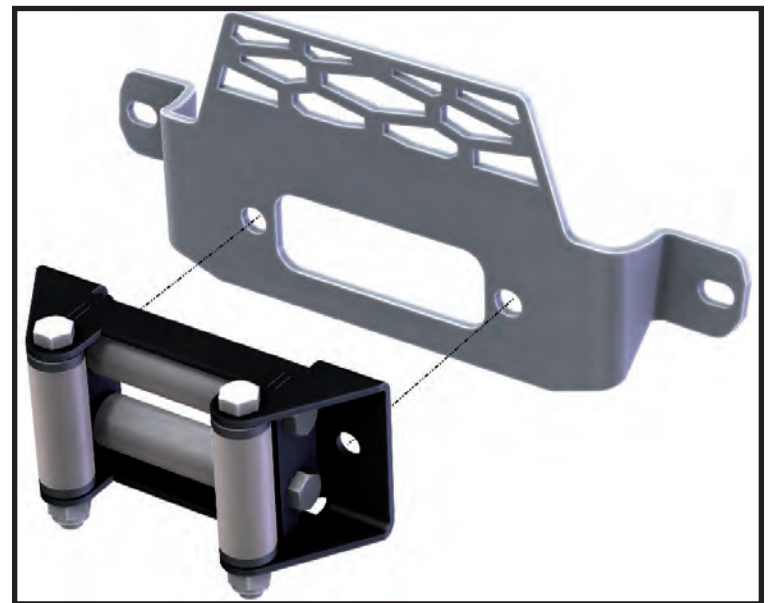

“Figure 9” Roller Fairlead Install



Polaris RZR 1000 Spacer Kit

Hardware Kit # HK-318

- (2) 3/8"-16 x 1.5" Hex Flange Bolts
- (12) 3/8" USS Flat Washers

For the Polaris RZR 1000's you may need to use this spacer kit to fill the gap between the mount and the RZR Frame. You will need to use at least 5 washers per side but we have included 6 washers for each side to accommodate variances in the frames. You will use the Hex Flange Bolts from hardware kit #HK-318.

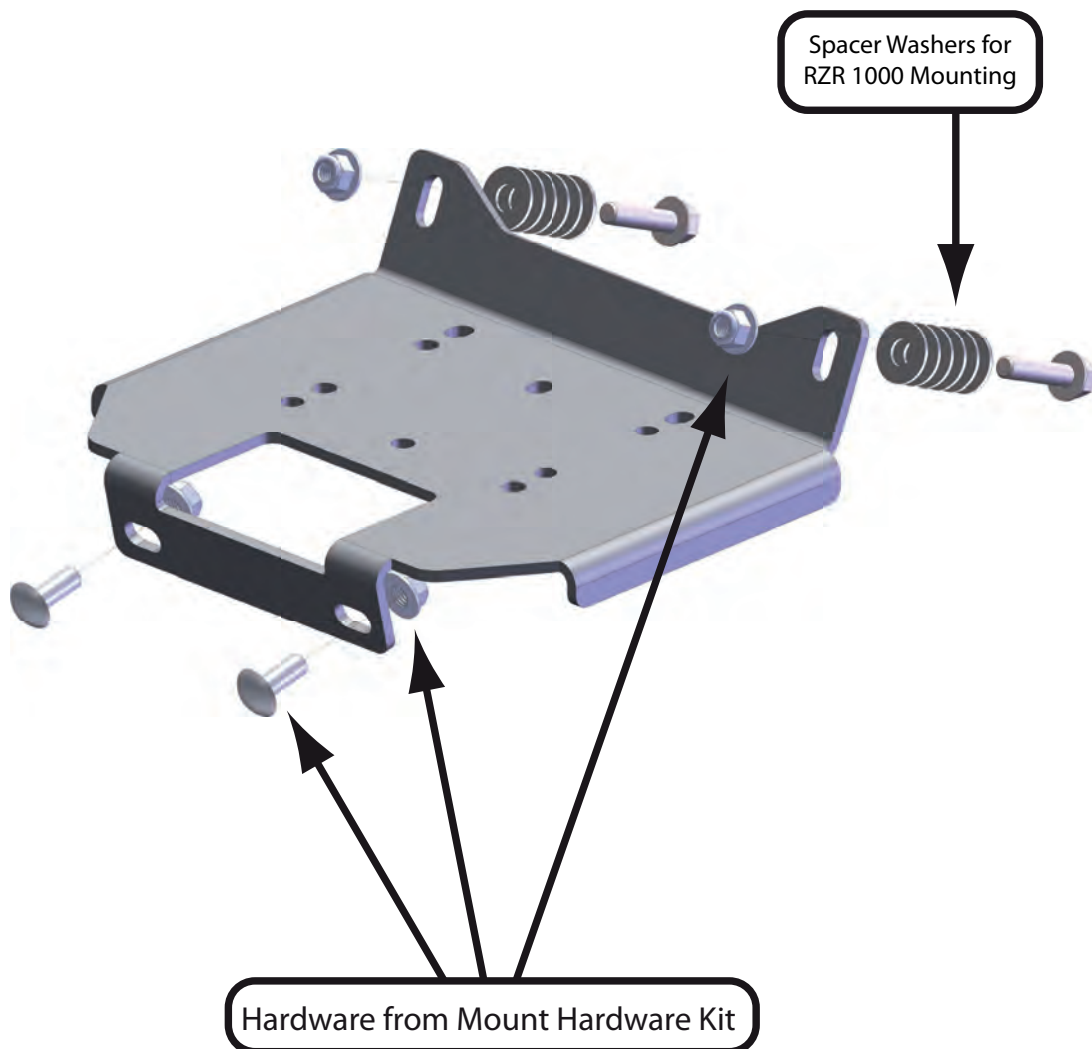

WIRING INFORMATION

1. For contactor location please see “Figure 11”. There is no set location for the contactor on this machine. *We suggest placing it some where under the hood that is out of the elements.*

Note:

The wires will need to be switched for this machine. The longer wires (Blue/Yellow) will be used to go from the battery to the contactor. The shorter wires (Black/Red) will be used to go from the winch to the contactor. See Figure 15 on Page 5.

2. Mini-Rocker Switch Hardware kit. This allows you to mount your usual handle bar mounted switch to almost any desired location.
 - a. Remove handlebar mount hardware from the switch.
 - b. Locate desired mounting location
 - c. Mark and drill two switch holes through dash using switch housing as a template
 - d. Drill a 3rd hole for the switch wiring.
 - e. Assemble per Figure 14.
3. Find a location that suits your purposes for the mini-rocker switch and hand remote.
4. Wire the red ignition wires from controllers to the acc post (+) as shown in Figure 13.

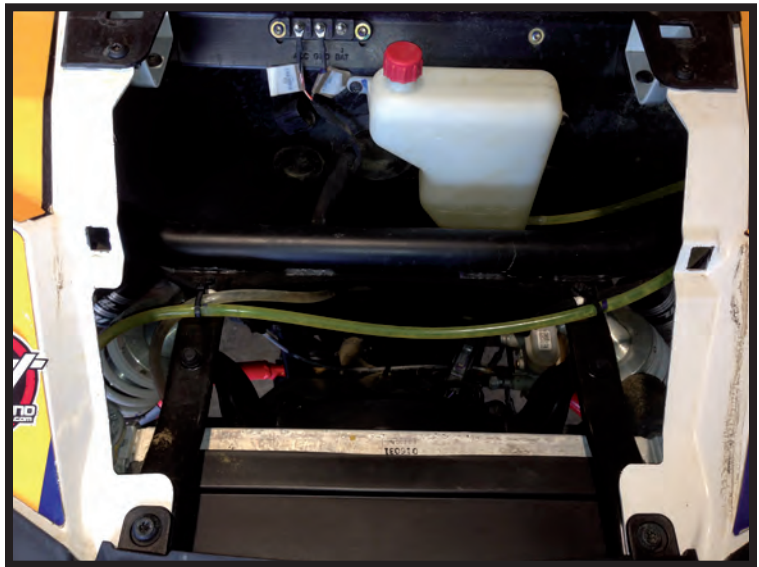

“Figure 11” Contactor Location
(Located under the hood.)



“Figure 12” Battery Location
(Battery is located under driver seat.)

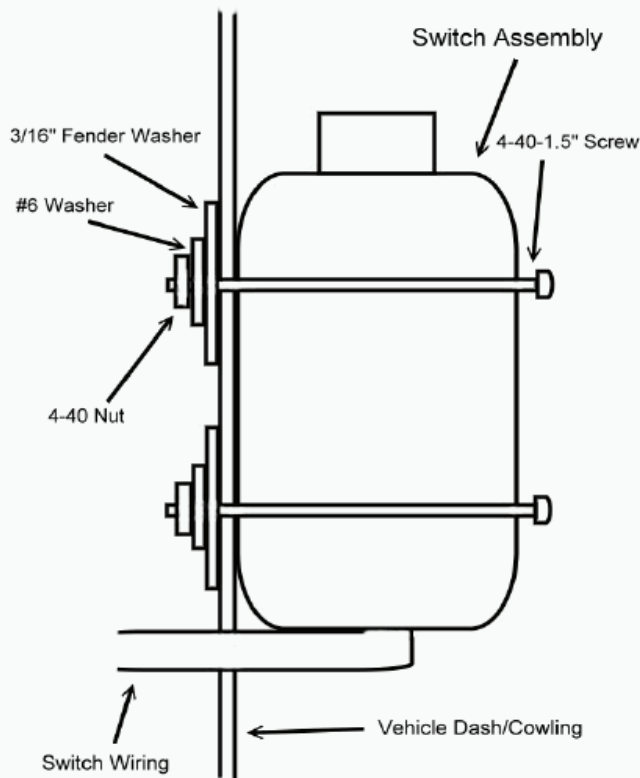

Optional Switch Mount Instructions*

“Figure 14” Mini-Rocker Mounting

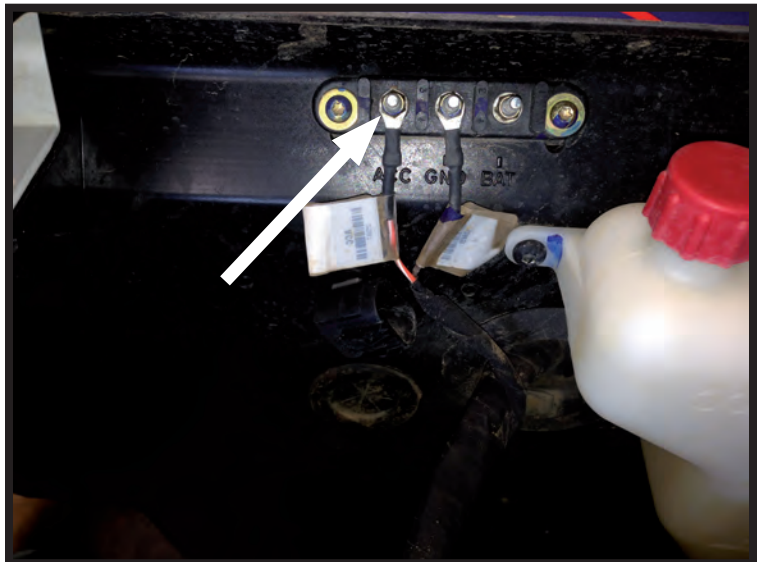

“Figure 13” Wire Location
(Located under the hood.)

ALTERNATE WINCH WIRING DIAGRAM

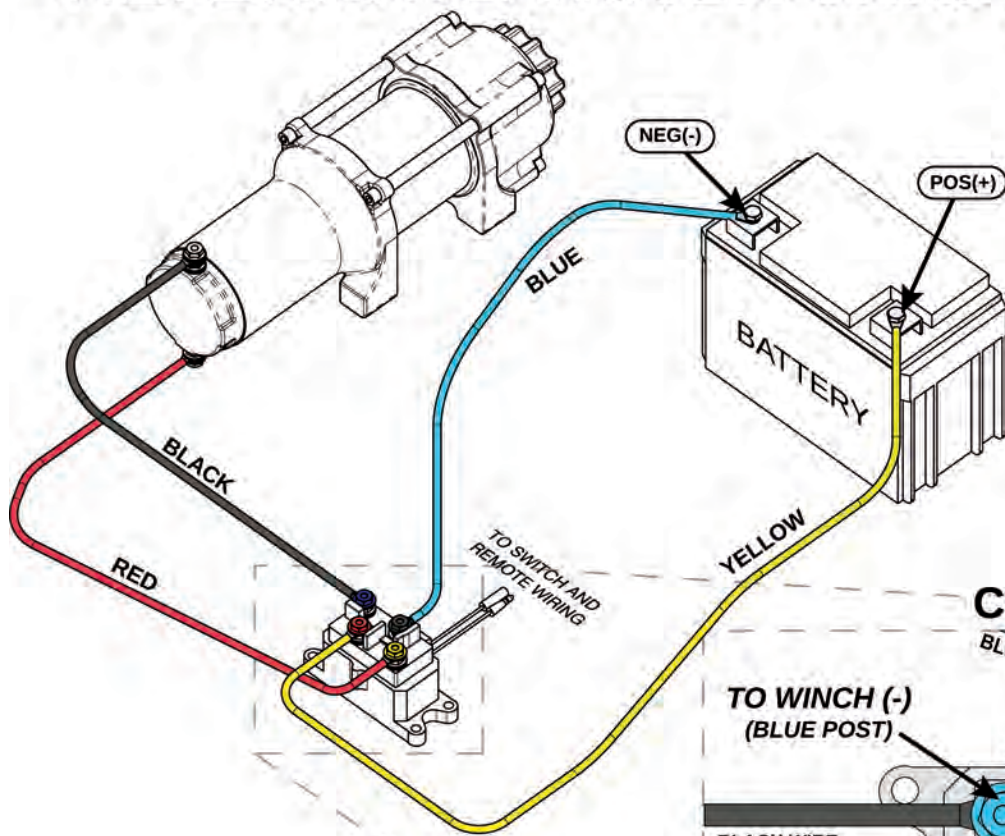

* For use with ATV/UTV applications where contactor cannot be located close to vehicle battery.

* Run shortest wires, usually red & black from contactor to winch; run longest wires, usually blue & yellow from contactor to battery.

⚠ CAUTION ⚠
 These two posts must be wired to the battery!

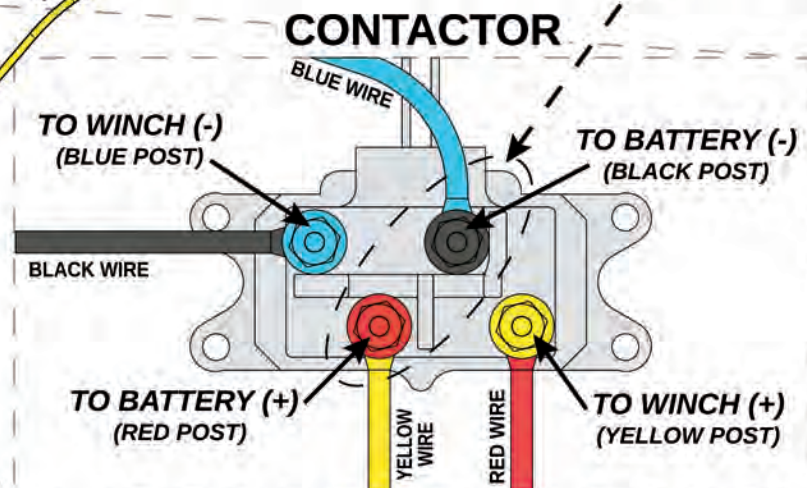

⚠ CAUTION ⚠
 FAILURE TO FOLLOW WIRING DIRECTIONS AS SHOWN MAY RESULT IN DAMAGE TO YOUR WIRING SYSTEM OR EQUIPMENT.

- WIRE WINCH NEGATIVE (BLACK WIRE) TO --> BLUE CONTACTOR POST
- WIRE WINCH POSITIVE (RED WIRE) TO --> YELLOW CONTACTOR POST
- WIRE BATTERY NEGATIVE (BLUE WIRE) TO --> BLACK CONTACTOR POST
- WIRE BATTERY POSITIVE (YELLOW WIRE) TO --> RED CONTACTOR POST

“Figure 15” Alternate Wiring Diagram