

Honda Pioneer 1000

Front Receiver

Receiver PART # 101365
 Hardware Kit: HK-037

Kit Components:

Item #	Qty.	Description
1	1	Receiver Mount
2	2	Brackets
3	2	3/8-16 x 1-1/4" Hex Flange Bolt
4	6	3/8-16 Nylock Nut
5	6	3/8-16 x 3" Flat Washer
6	4	3/8-16 x 1" Shortneck Carriage Bolt
7	3	5/16-18 x 1" Hex Bolt (Won't Use)
8	3	5/16" Lock Washer (Won't Use)

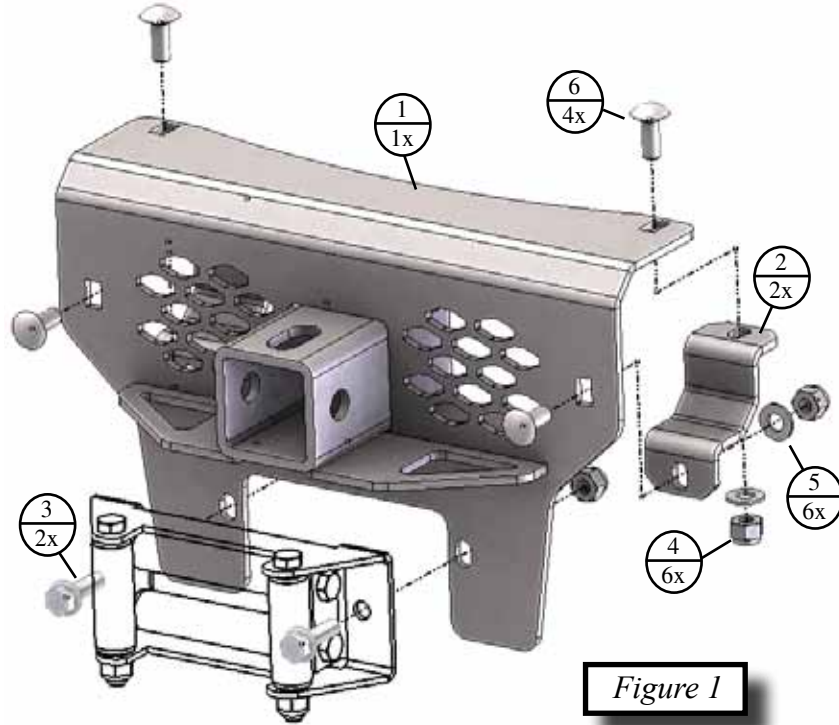

Figure 1

INSTALLATION INSTRUCTIONS:

Note: Make sure all of the hardware needed to complete this mount are in the package. You will not be using all the hardware provided. Read through and understand the instructions before installing.

1. Remove the front bumper. Start by taking off the cap screws (A) holding the plastic to the bumper on each side. Remove the two bolts (B) on the bottom of the bumper as shown in Figures 2 & 3, and the four bolts (C) in the bumper tube as shown in Figure 3.

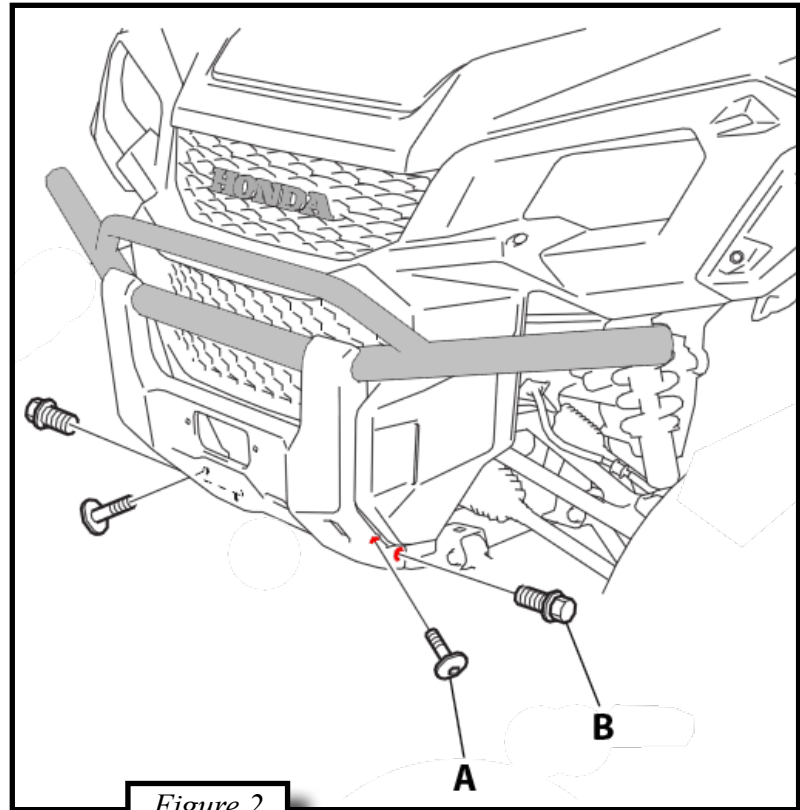

Figure 2

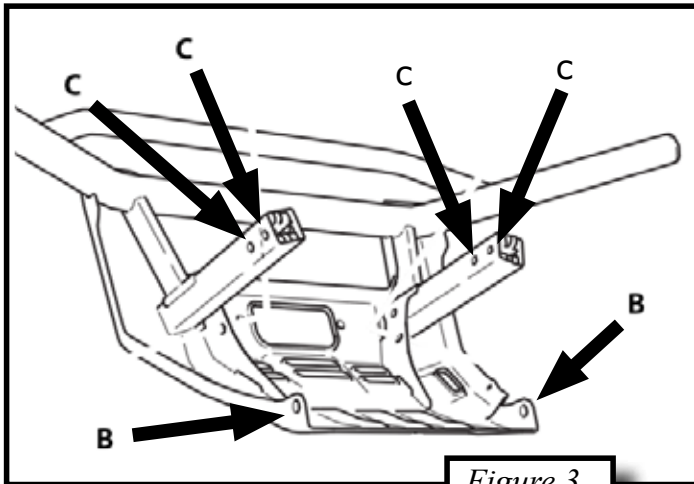

Figure 3

Note: If you have a roller fairlead attached to your bumper from a previous winch install, you will need to removed it at this time.

2. Set the receiver mount on the front of the bumper and attach it setting the brackets (2) around the bumper tubing and bolt down loosely & evenly using the four 3/8 carriage bolts, nuts and washers. As shown in Figures 1 & 4.

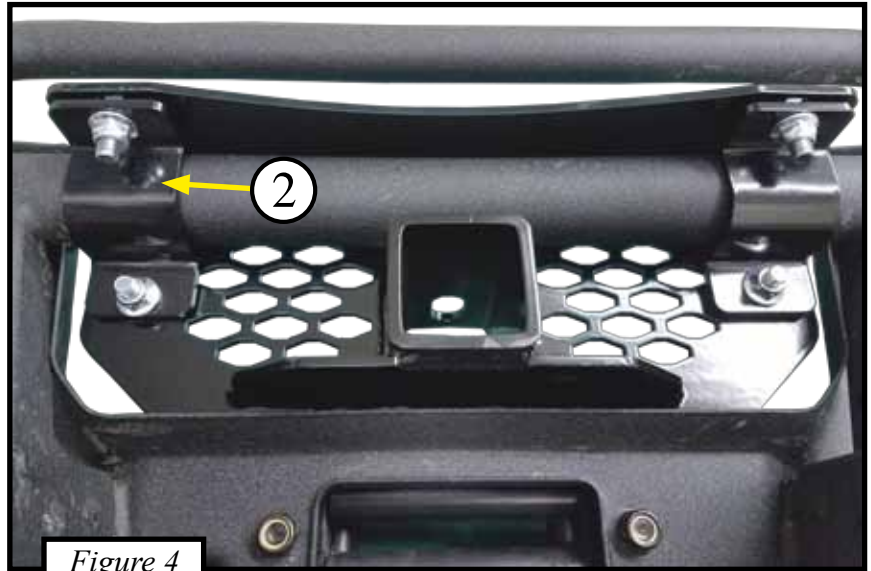

Figure 4

3. Line the receiver mount up with the OEM holes for a roller fairlead. If you have a winch continue to step 4 if not skip to step 5.

4. If you have a winch you will need to attach your roller fairlead to the receiver mount and bolt down using the two 3/8 flange bolts and nuts. Shown in Figures 4 & 5. Skip to Step 6.

5. Attach the lower part of the receiver to your bumper using the 3/8 carriage bolts going through the OEM holes.

6. Tighten all of your hardware down to your bumper, making sure that your brackets (2) are tightened evenly.

7. Reattach the bumper to your machine the same way it was removed per instructions above.



Figure 5

