

# Polaris Ranger XP Midsize

## Bumper

PART # 101435

### Kit Components:

Item #	Qty.	Description
1	1	Bumper
2	2	Bumper Brackets - Driver & Passenger Side
3	4	Bumper Tube Cap
4	1	HK-344
4.1	8	3/8"-16 x .75 Carriage Bolt GR5 Zinc
4.2	8	3/8"-16 Hex Flange Nylock Nut GR5 Zinc
4.3	6	5/16"-18 x .75 Carriage Bolt GR5 BLK
4.4	6	5/16"-18 Hex Flange Nylock Nut GR5 Zinc
4.5	2	5/16"-18 x 1" Hex Bolt Flange Self-Tapping
4.6	2	1/4"-20 x .75 Hex Bolt Flange Self-Tapping (NOT USED)

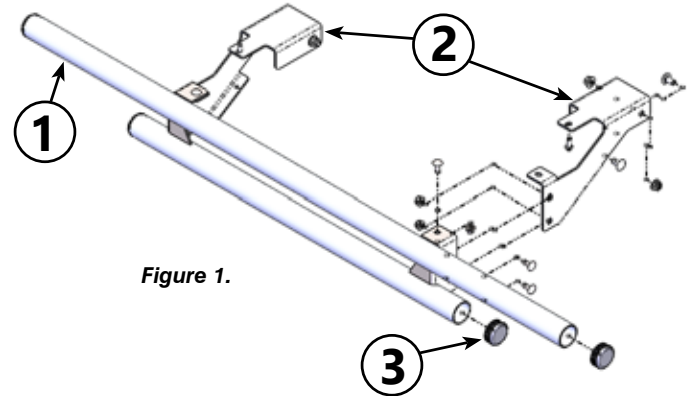

Figure 1.

### Installation:

1. Assemble tube caps (3) to bumper tubes (1) as shown in [Figure 1](#).
2. Locate the OEM wiring harness under the rear most portion of the dump box.
3. Pull out two retaining clips (A) for the wiring harness; they are located towards the inside of the frame tubes labeled (B) in [Figure 2](#). **NOTE:** Pull out only the ones closest to each of the frame tubes labeled (B)!

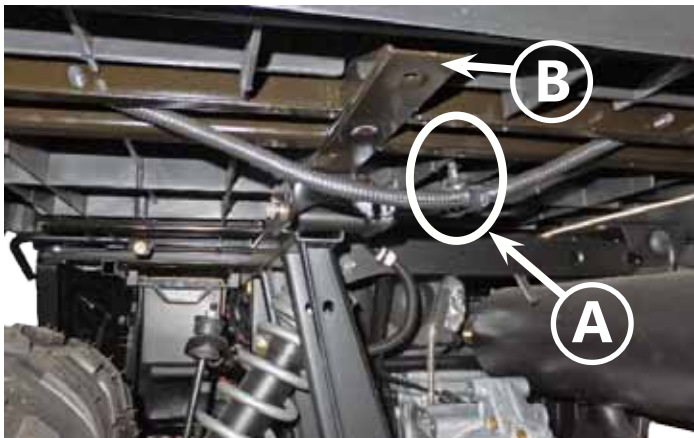

Figure 2. - Drivers Side.

4. Maneuver the bumper brackets (2) into position by sliding them over top of the wiring harness and onto the bed hinges as shown in [Figure 3](#).
5. Hold the bumper bracket in place and run 4x 3/8"-16 x .75" (4.1) carriage bolts through the square slots in the frame and holes in the bumper brackets (2). Bolt heads will be on the inside of the bracket.
6. Loosely fasten 3/8" Hex Flange Nylock Nut (4.2) as shown in [Figures 1 & 3](#). Do not tighten.

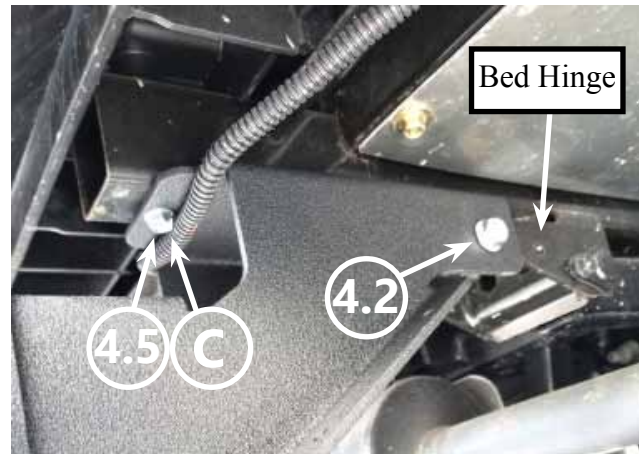

Figure 3. - Passenger Side

7. Run 2x Self-Tapping screws (4.5) up through location (C) and into the box frame as shown in [Figure 3](#). Turn until hand-tight only! Do not over-tighten or you may strip the hole.
8. Once bumper brackets are installed, fasten bumper (1) to bumper brackets (2) using 6x 5/16"-18 x .75 Carriage Bolt GR5 BLK (4.3) and 6x 5/16"-18 Hex Flange Nylock Nut GR5 Zinc (4.4) as shown in [Figure 4](#)
9. Tighten all remaining hardware evenly.

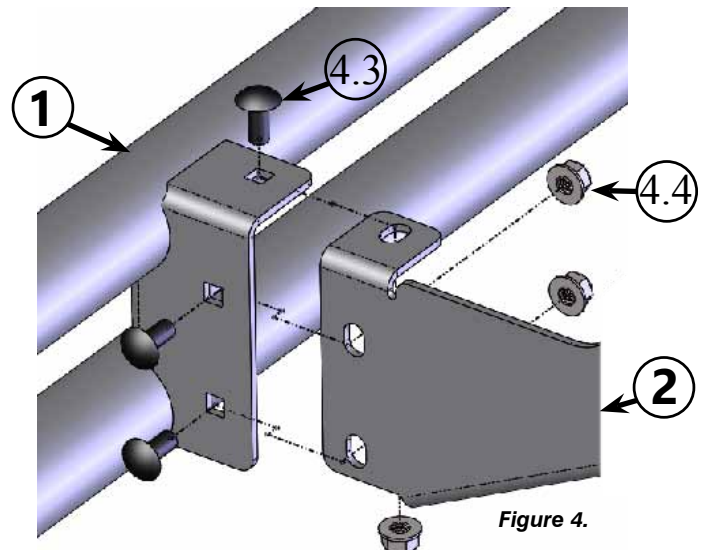

Figure 4.