

CAN-AM MAVERICK X3

WINCH MOUNT

Winch Mount

PART # 101520

Hardware Kit: HK-087

Kit Components:

Item #	Qty.	Description
1	1	Winch Mount
2	1	Fairlead Mount
3	2	3/8"-16 X 1" Hex Bolt
4	2	3/8"-16 Nylock Nut
5	4	3/8" SAE Flat Washer

INSTALLATION INSTRUCTIONS:

Note: Make sure all of the hardware needed to complete this mount is in the package. Read through and understand the instructions before installing.

FRONT BUMPER REMOVAL:

1. Remove two bolts (A) as shown in [Figure 2](#).

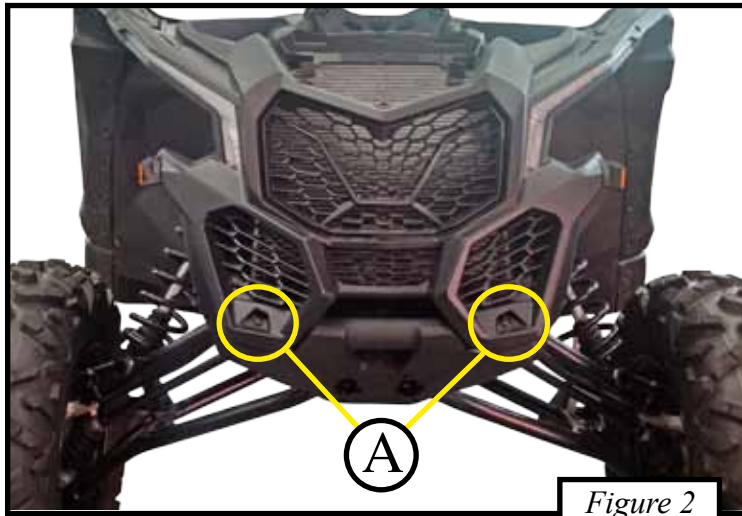

2. Remove two rear bolts (B), one on each side as shown in [Figure 3](#).

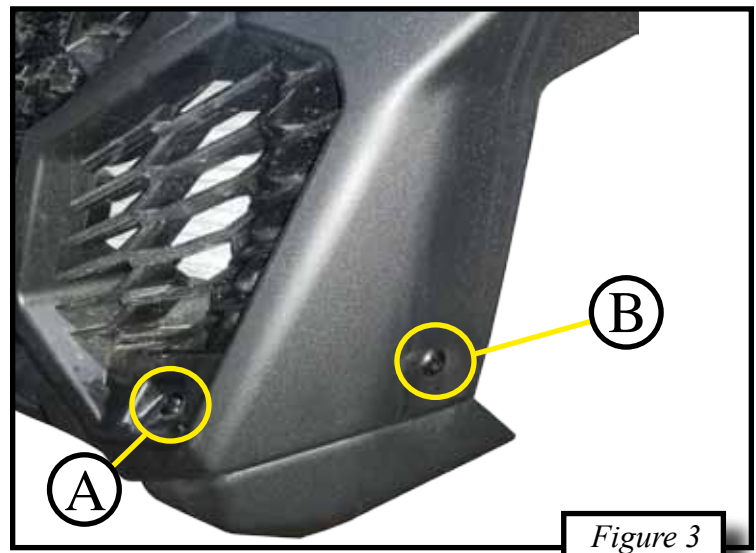

3. Remove two upper bolts (C) from both sides as shown in [Figure 4](#).

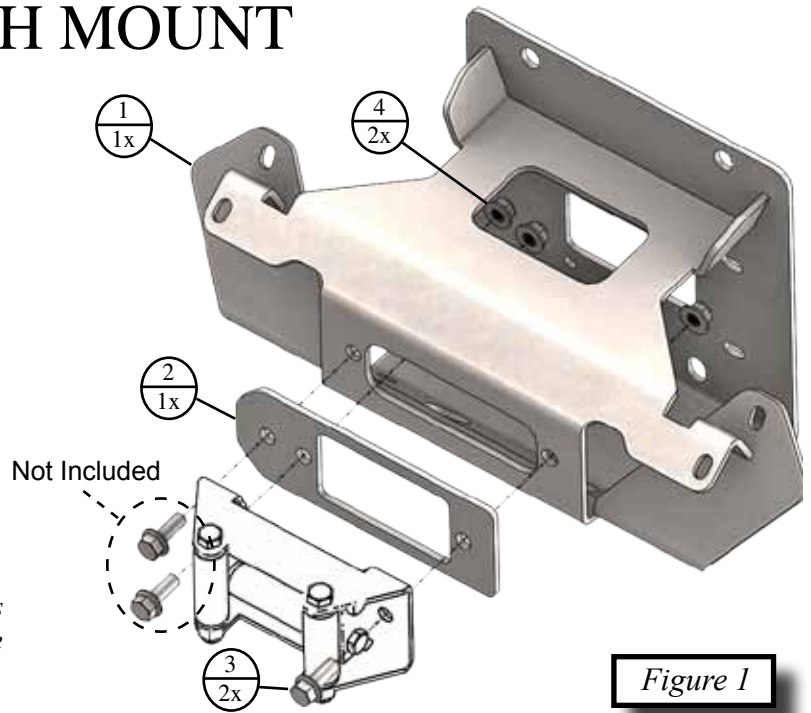
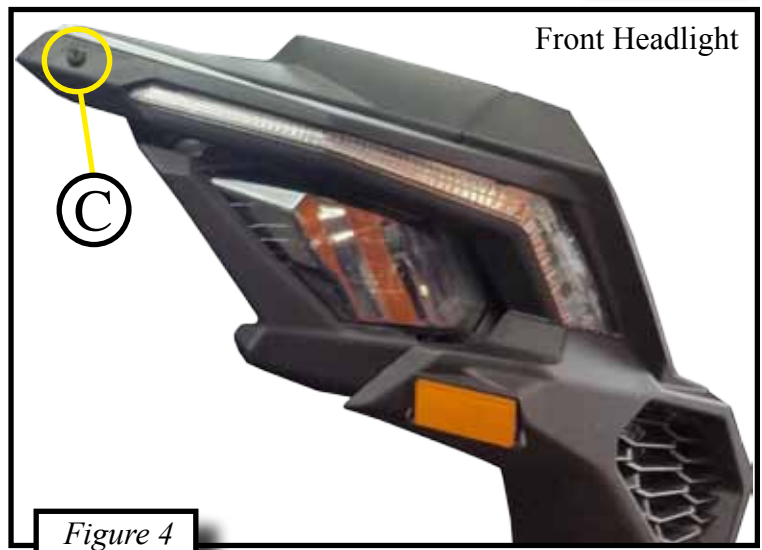
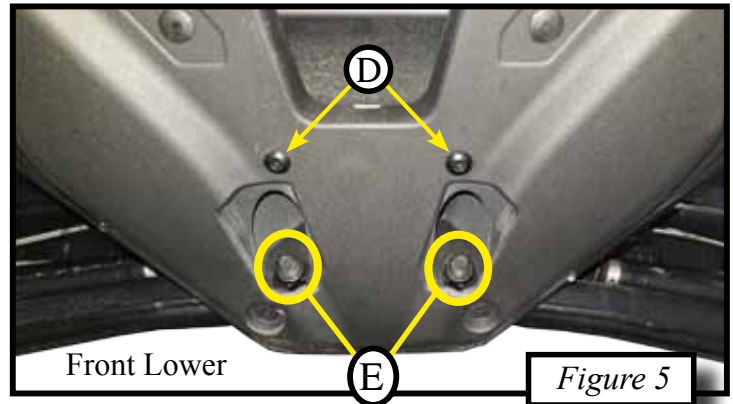

Figure 1

Figure 3

Figure 4

4. Remove two screws (D) and remove two lower A-arm nuts (E) as shown in Figure 5.



5. Remove two front upper A-arm nuts (F) as shown in Figure 6.

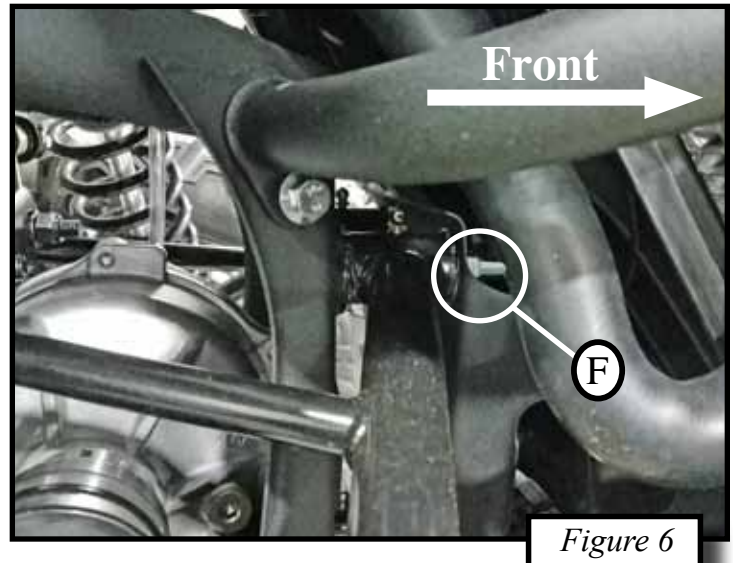

6. Remove two upper radiator bolts (G) and two lower radiator bolts (H) as shown in Figure 7.

7. Remove two threaded clips (I) as shown in Figure 7. (Keep clips, they will be used in future install step).

8. Place small strap around center of shock tower and upper radiator mount as shown in Figure 8. Tighten strap, lifting radiator to allow access to remove OEM bumper and installation of KFI winch mount.

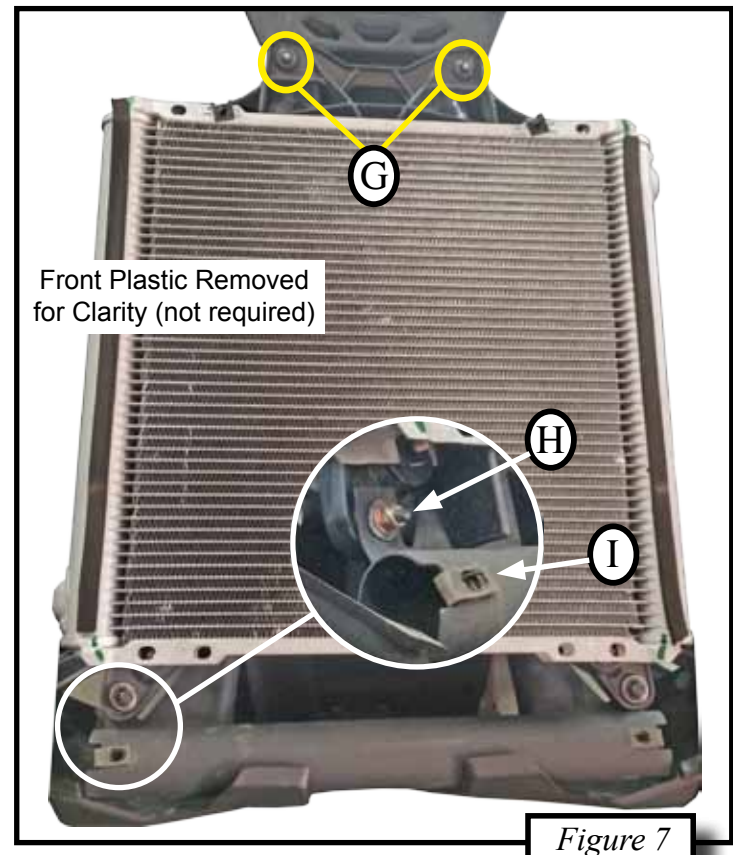

9. Remove lower factory bumper and discard.

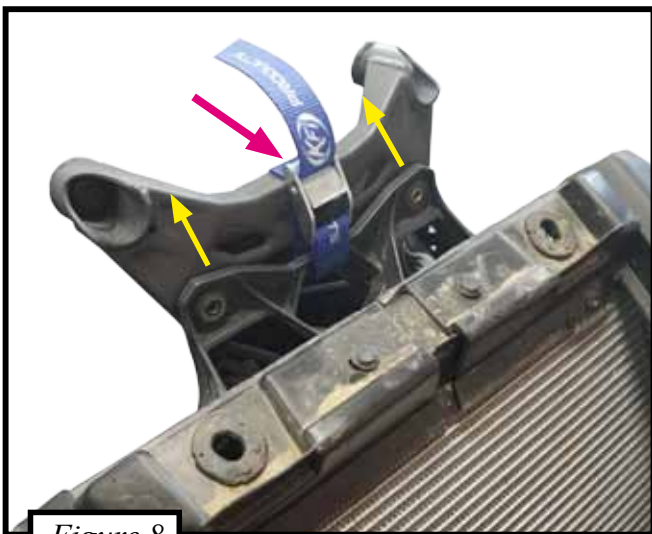

10. Place factory threaded clips (I) removed in (step 7) onto the KFI winch mount. Shown in Figure 9.

11. Place the winch mount under the grill and line up the four holes in the mount with the A-arm bolts. Attach the nuts (E) & (F) previously removed to secure the mount in place. Tighten down all four bolts. Shown in Figures 10 & 11.

12. Attach the radiator to the back side of the winch mount using the factory bolts (H) previously removed in (step 6) show in location (H). See Figures 9 & 13.

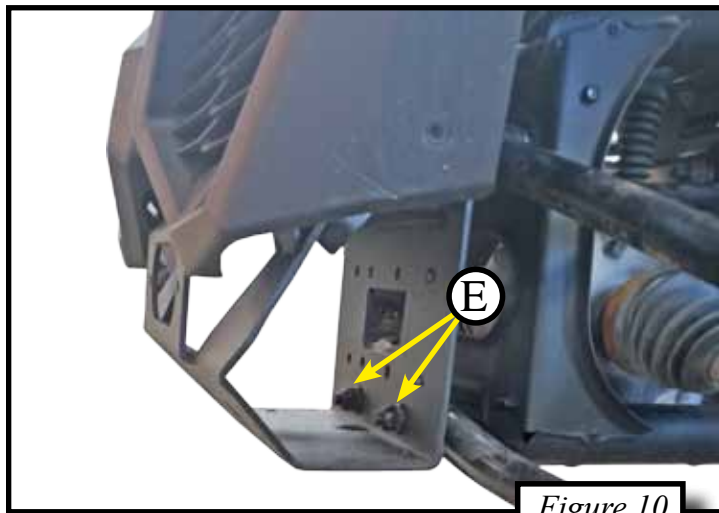

Figure 10

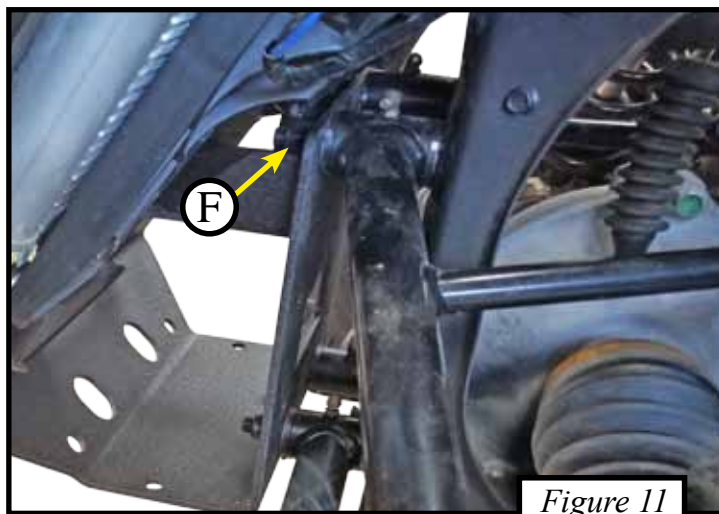

Figure 11

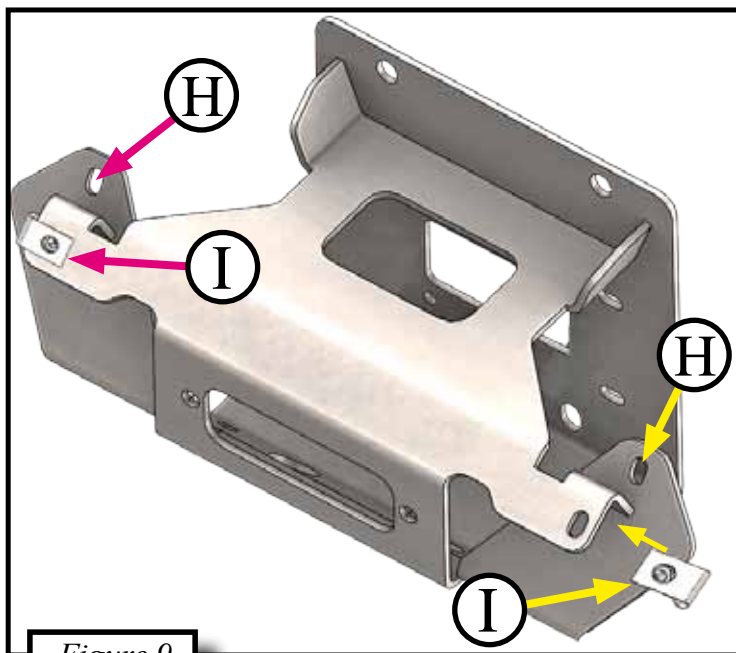
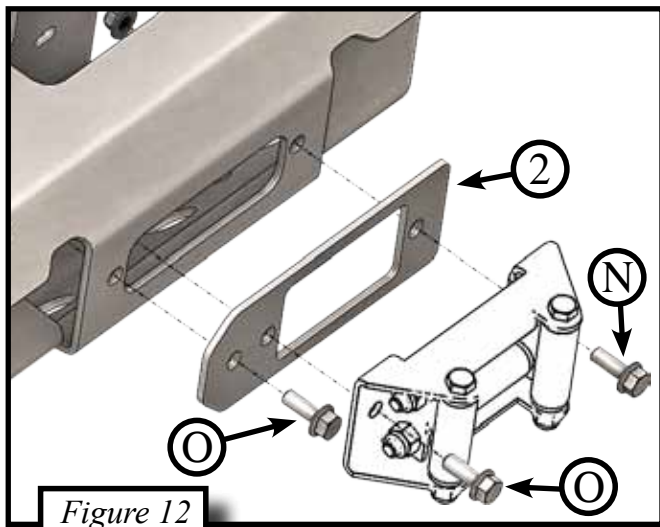

Figure 9

13. If you have a standard winch with a standard bolt pattern (4.875" x 3") attach the roller fairlead to the bumper sandwiching the fairlead bracket (2). Use the metric bolts (O) that are included in with your winch, and single 3/8" bolt (N) supplied. Shown in Figure 12.

14. If you have a WIDE winch discard the fairlead bracket and attach your roller fairlead straight to the winch mount using the hardware supplied with your winch.



NOTE: For wide winches use holes (X), for standard winches use holes (Y) and two hole winches use holes (Z). Shown in Figure 14.

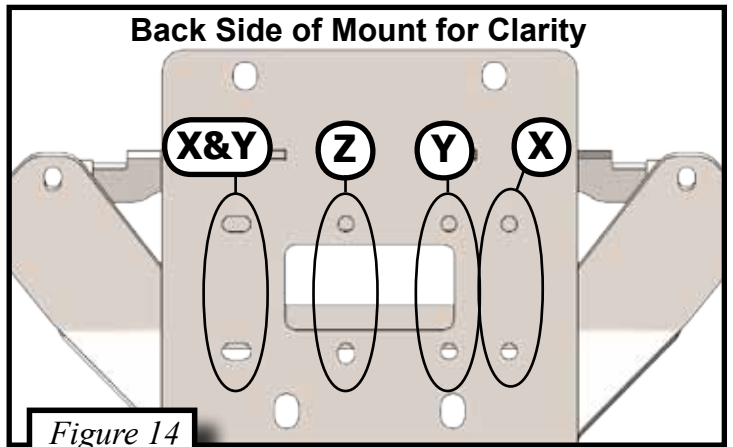

16. When the winch is installed make sure the cable is spooling off the winch between the tie bars as shown in Figure 15.

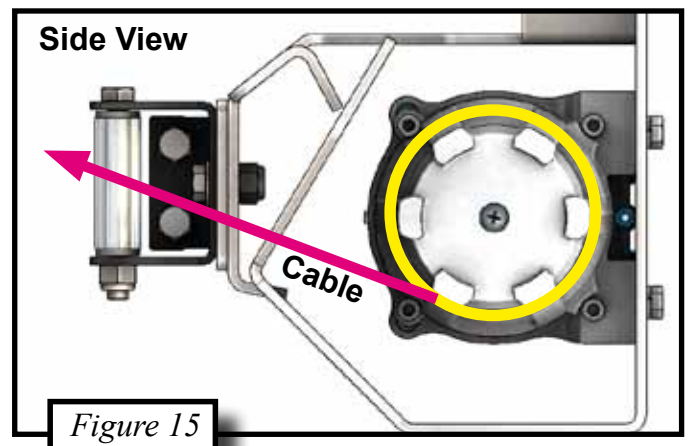

15. Place the winch inside of the mount with the mounting holes facing the rear of the machine, and the clutch on the drivers side. Bolt the winch to the mount using the hardware provided with your winch. Shown in Figures 13 & 14.

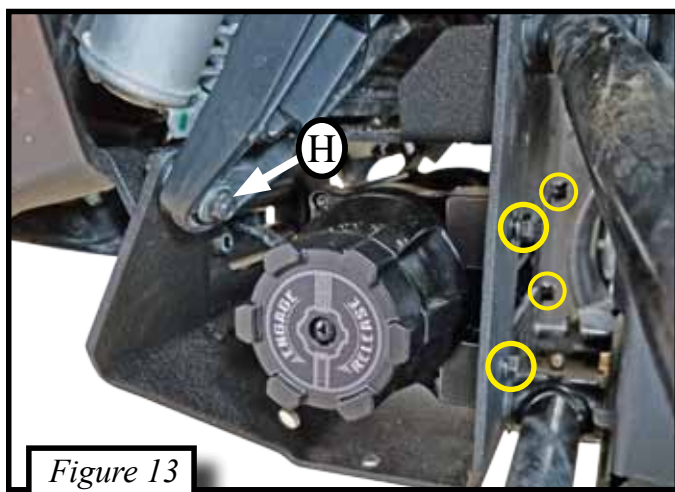

Winch Wiring

17. Before wiring first remove the two bolts (J) behind the passenger seat. Shown in [Figure 16](#).

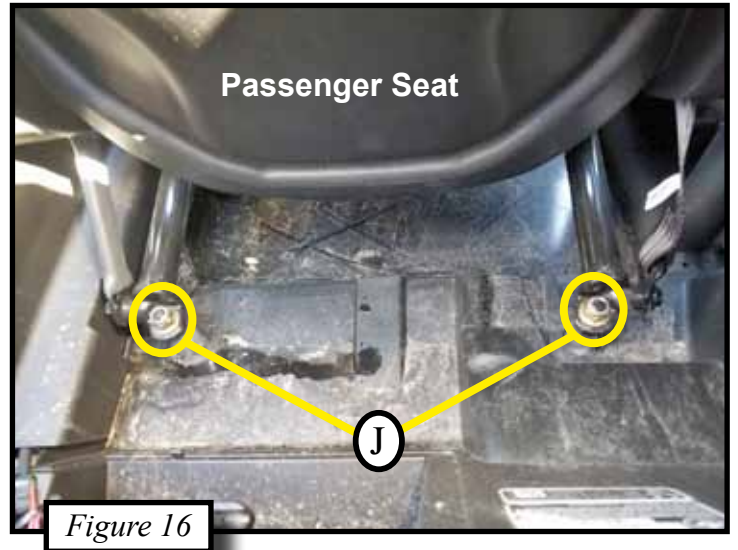

18. Remove the two bolts (K) in the front of the passenger seat, and remove the seat from the machine. Shown in [Figure 17](#).

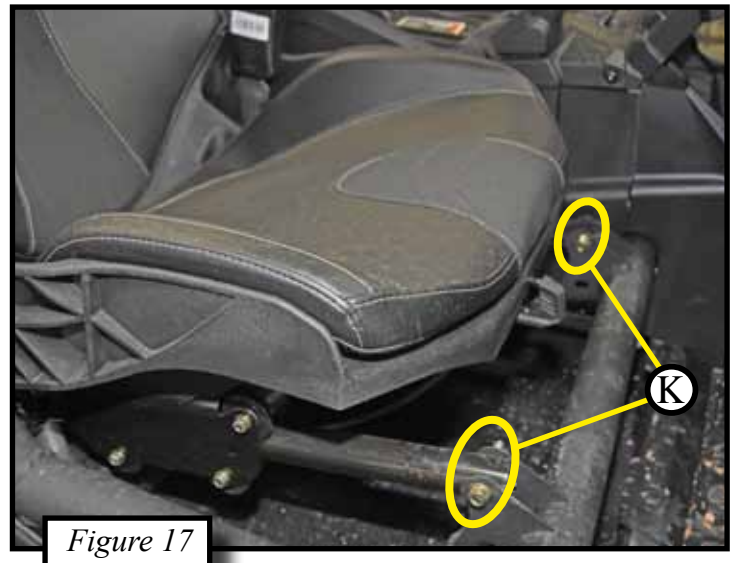

19. Next you can remove the passenger side panel under the center console to expose the wires.

20. Attach the contactor behind the passenger side panel under the center console. Shown in [Figure 18](#).

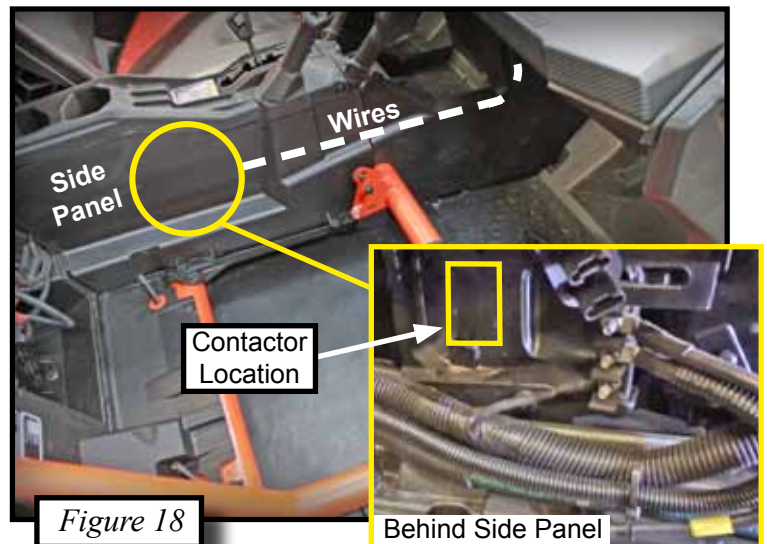

21. Attach the contactor to the bus bar located behind the passenger side panel using the red and black wires provided with your winch. The Red wire will connect to the center positive post. The Black wire will go to the to ground post. Shown in Figures 18 & 19.

22. Run your longer winch wires from the contactor up to the front of the machine following the dashed line shown in Figure 18.

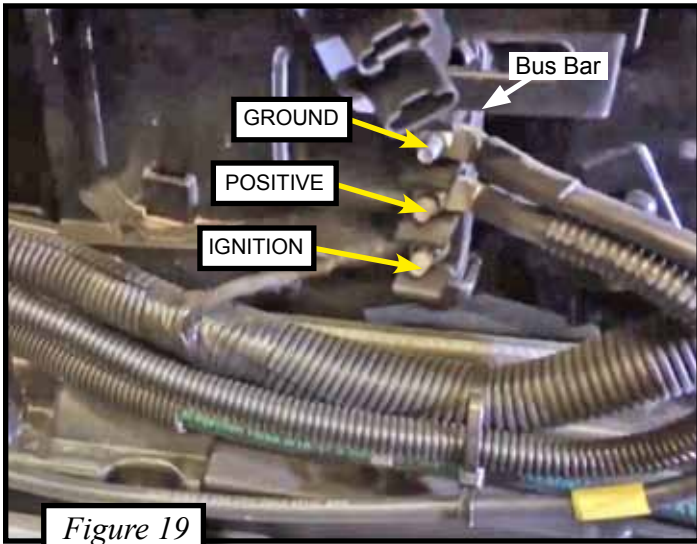

Figure 19

23. In the dash console of the Maverick X3 there are pre-notched holes for the dash rocker to mount to shown in Figure 20.



Figure 20

24. Route the switch wires from the dash down to the contactor location. Attach the ignition fed wire (RED) from your switch to the ignition post on the bus bar. Shown in Figure 19.

25. Connect the green and black switch wires to the green and black wires coming off the contactor. If you are installing an LED lit switch such as the KFI dash switch you will also need to connect the white ground wire from the switch to the ground post on the bus bar, or contactor according to your winch install manual.

26. For more details on wiring the winch see your winch manual.

