

POLARIS RZR TURBO S

Rear Receiver

PART # 101695

Hardware Kit: HK-011

Item #	Qty.	Description
A	1	KFI Linkage Plate
B	1	Receiver Plate
1	1	HK-011
1.1	4	3/8"-16 Flange Bolt
1.2	4	3/8"-16 Nylock Nut (Not Used)
1.3	4	3/8" SAE Flat Washer (Not Used)
1.4	1	3/8"-16 x 1 1/4 Flat Head Screw (Not Used)

INSTALLATION INSTRUCTIONS:

1. Find a jack to raise the rear end of the machine and take the pressure off the trailing arm linkages.
2. Remove nuts and bolts (C) on rear plate as shown in Figure 2. Plate will come off. Keep all hardware as it will be reused.
3. Using bolts and nuts removed in Step 2, replace bottom bolts through KFI linkage plate (A) and bottom trailing arms and install in the machine as shown in Figure 3. Follow same procedure for top two bolts. Tighten bolts and nuts to 33 ft. lbs. (45Nm).
4. Install the receiver plate (B) using the 3/8" Flange Bolts supplied in the hardware kit as shown in Figures 1&4.
5. Tighten all bolts.

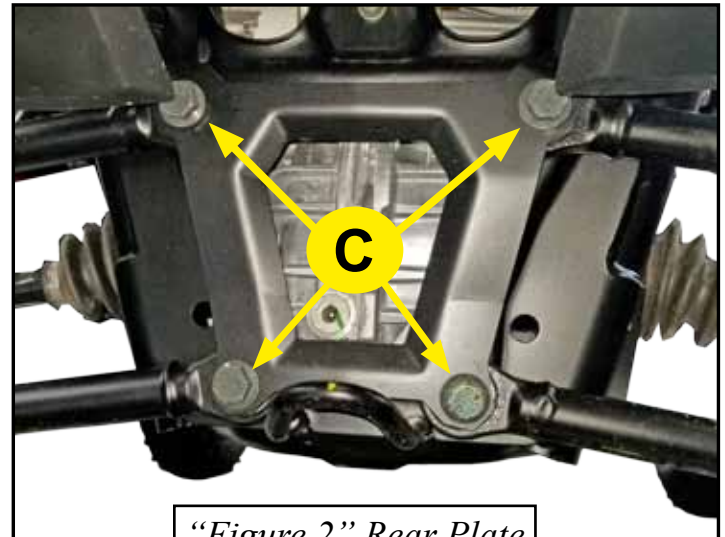
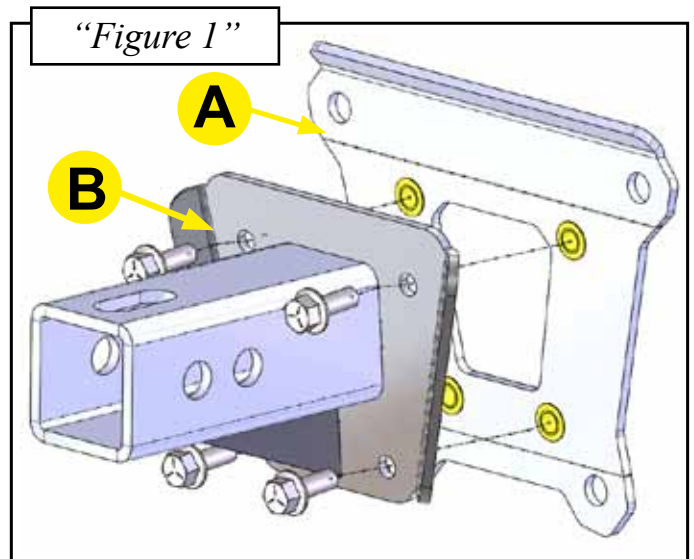

"Figure 2" Rear Plate

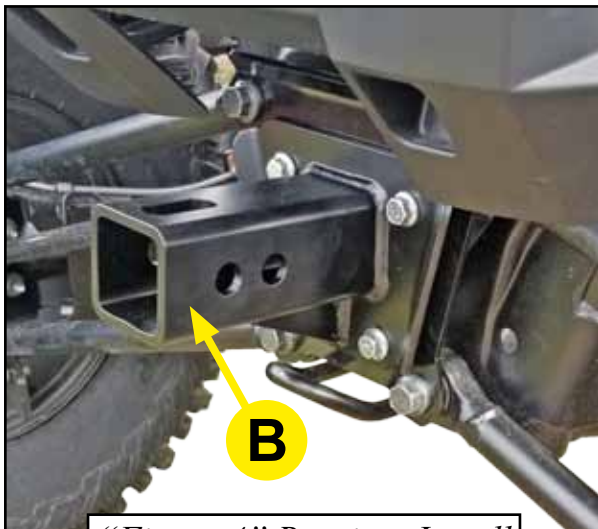

"Figure 4" Receiver Install

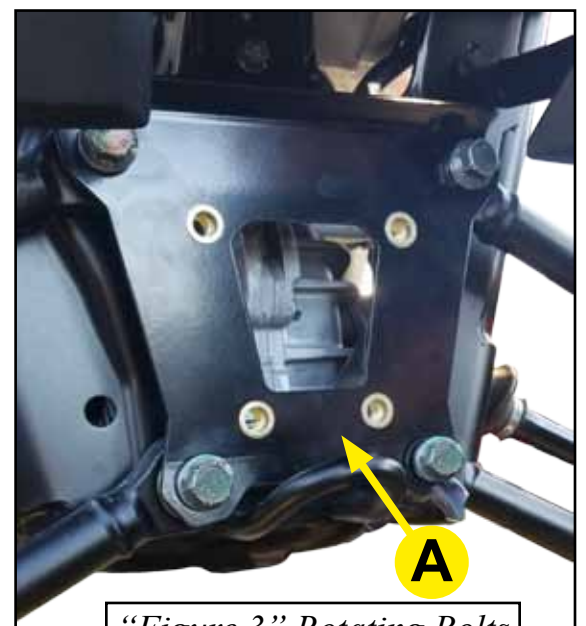

"Figure 3" Rotating Bolts

