

POLARIS SPORTSMAN XP

WINCH MOUNT

Winch Mount

PART # 101740

Hardware Kit: HK-338

Kit Components:

Item	Qty.	Description
1	1	Winch Mount
2	1	Bracket - Contactor Mount
3	4	M8-1.25 x 25MM Hex Head Bolt 8.8 Zinc
4	4	5/16" SAE Flat Washer Zinc
5	4	5/16" Lock Washer Zinc
6	2	1/4"-20 X 1" Hex Bolt GR5 Zinc
7	4	1/4"-20 Nylock Nut
8	2	1/4" SAE Flat Washer Zinc
9	2	3/8"-16 X 3/4" Shortneck Carriage Zinc
10	2	3/8"-16 Nylock Nut
11	1	M6X1.0 X 18MM Hex Head GR5 Zinc
12	1	Male Disconnect .250 X .032 22-18GA Insulated Red Vinyl
13	2	3/8"-16 X 1" Short Neck Carriage Bolt GR5 Zinc
14	2	3/8"-16 Nylock Flanged Nut GR5 Zinc
15	2	1/4"-20 X 1-1/2" Hex Flg Self-Tap Screw Zinc
16	2	1/4"-20 X .75" Carriage Bolt GR5 ZP

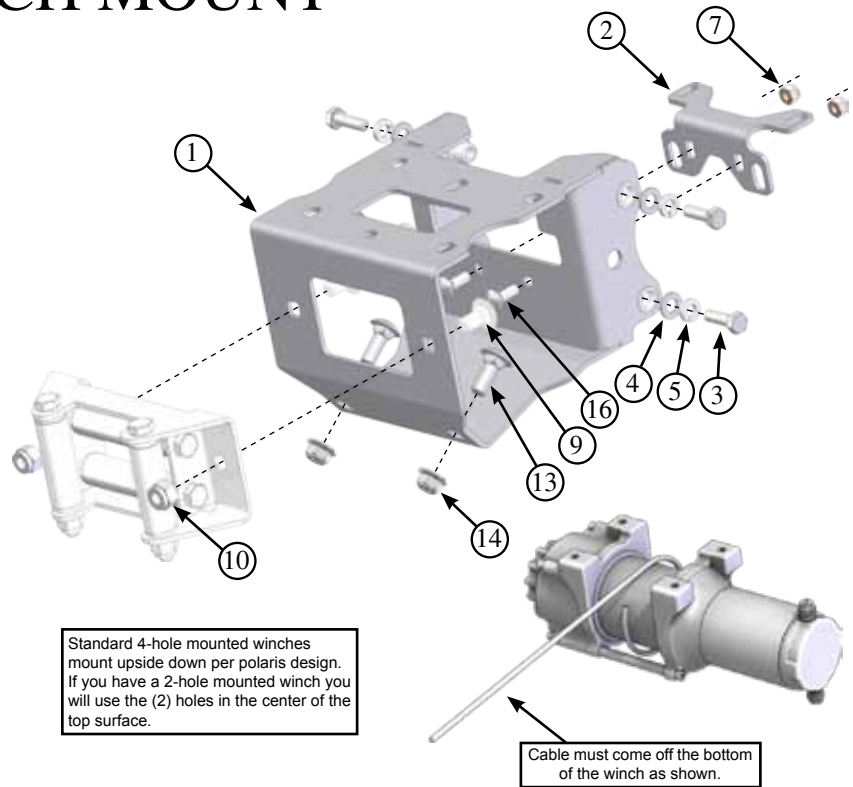

“Figure 1” Exploded View

INSTALLATION INSTRUCTIONS:

1. Assemble the Hawse or Roller Fairlead (not included) to the mount as shown using the supplied 3/8" x 3/4" carriage bolts (9) and nuts (10) “shown in figure 1”.
2. If you are planning on installing a Polaris Glacier Plow please install the included 3/8" x 1" carriage bolts (13) and nuts (14) at this time to the lower square holes. “Shown in figure 1”
3. Remove any accessory front brush guards if equipped.
4. Remove the front plastic:
 - 550/850 XP:** Remove the bolts “shown in Figure 2” and remove the plastic. Loosen the 2 bolts as “shown in Figure 3” and rotate the metal cover downwards to allow for room to install the winch assembly. If preferred, you can remove the metal/plastic cover in Figure 3 by removing the upper hardware.
 - 400/450/500/570/800:** Remove the bolts “shown in figure 2” and remove the front plastic. Cut out section (A) “shown in Figure 2”.
5. Remove the seat, disconnect battery, and remove the front rack.
6. Disassemble the light pod.
7. Remove access panel under light pod.



“Figure 2” Removal of Front Plastic

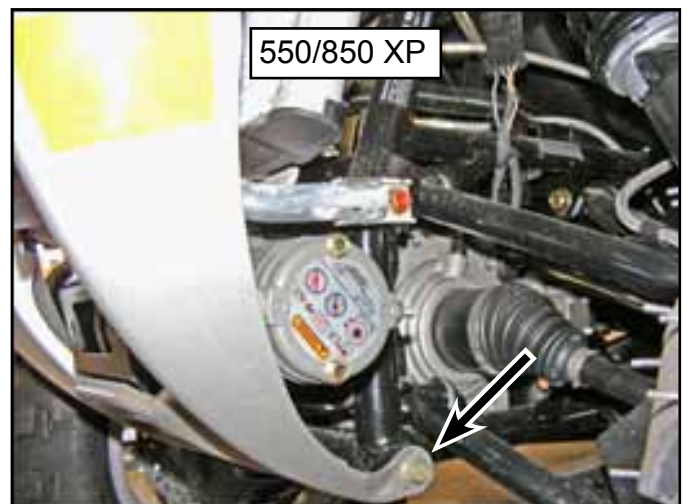

“Figure 3” Loosen Bolts

8. Depending on your machine there are five different positions for the contactor to mount. See the chart below and follow the directions on the position called out on the following pages.

WINCH MOUNTING POSITIONS

Year	CC	Model	Position
2011-2014	400	Sportsman	Position 5
2016-2018	450	Sportsman	Position 1
2011-2013	500	Sportsman	Position 5
2011-2013	500	Sportsman Touring	Position 5
2011-2014	550	Sportsman / XP	Position 4
2010	550	Sportsman Touring	Position 3
2011-2014	550	Sportsman Touring	Position 4
2010	550	Sportsman X2	Position 3
2011-2014	550	Sportsman X2	Position 4
2009-2010	550	Sportsman XP	Position 3
2014-2018	570	Sportsman	Position 1
2017-2018	570	Sportsman 6x6 Big Boss	Position 1
2014-2018	570	Sportsman Touring	Position 1
2015-2018	570	Sportsman UTE	Position 1
2015-2018	570	Sportsman X2	Position 1
2011-2014	800	Sportsman	Position 5
2011-2015	800	Sportsman 6x6 Big Boss	Position 5
2015-2018	850	Scrambler	Position 2
2013-2014	850	Scrambler XP	Position 2
2015-2016	850	Sportsman	Position 4
2017-2018	850	Sportsman	Position 2
2017-2018	850	Sportsman High Lifter	Position 2
2010	850	Sportsman Touring	Position 3
2011-2018	850	Sportsman Touring	Position 4
2009	850	Sportsman XP	Position 3
2010-2014	850	Sportsman XP	Position 4
2014-2018	1000	Scrambler XP	Position 2
2015-2018	1000	Sportsman Touring XP	Position 4
2015-2016	1000	Sportsman XP	Position 4
2017-2018	1000	Sportsman XP	Position 2
2017-2018	1000	Sportsman XP High Lifter	Position 2
2015	ETX	Sportsman ETX	Position 1

POSITION 1

1. Top mounted contactors will use the supplied contactor mount bracket (2), the 1/4" hex bolts (6), washers and 1/4" nylock nut (7). You will need to mount the winch to be able to attach the bracket (2). The bracket is held to the mount using two of the four winch mounting bolts.

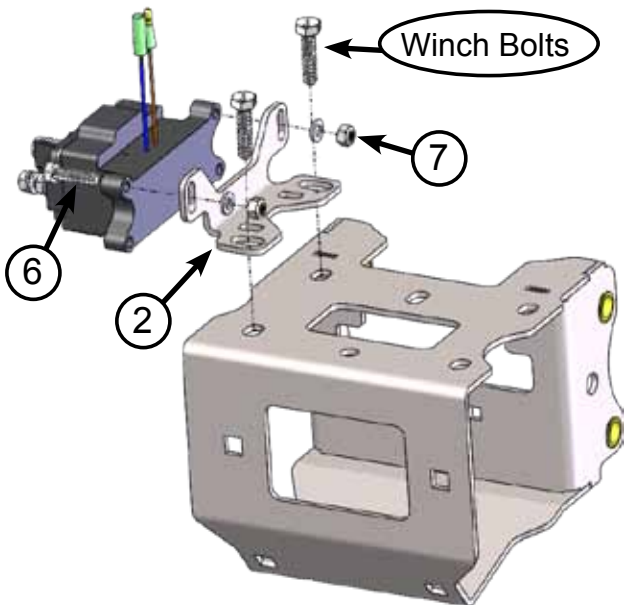

2. Slide the winch into the mount per orientation shown in [Figure 1](#). Mount your winch to the Mount using the proper hardware supplied with your winch. Don't forget to route your winch cable through your fairlead and attach your hook. If your winch leads come close to hitting something, a lot of winches can also have the leads rotated if needed (check with your winch provider).
3. Mount the entire winch assembly (winch, mount, contactor, and fairlead) into location and assemble using the included 8MM hardware. Shown in image below.
4. Wire the winch up per the instructions that came with your winch.

Note: Under the front rack there is a orange and white accessory wire that you can tap your switch into.

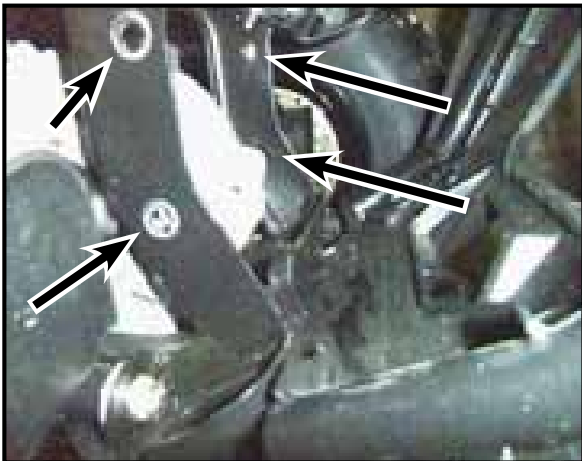

POSITION 2

1. Rear mounted contactors will use the contactor mount bracket (2). Attach the contactor to the bracket using the 1/4" hex bolts (6), washers and 1/4" nylock nut (7). Fasten the contactor assembly to the mount with the supplied 1/4" Carriage Bolt (16) and 1/4" Nylock Nut (7).

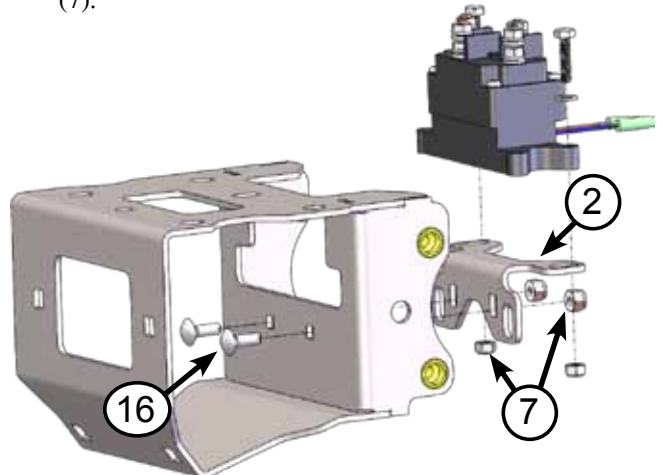

2. Slide the winch into the mount per orientation shown in [Figure 1](#). Mount your winch to the Mount using the proper hardware supplied with your winch. Don't forget to route your winch cable through your fairlead and attach your hook. If your winch leads come close to hitting something, a lot of winches can also have the leads rotated if needed (check with your winch provider).

Note: With a (Rear) mounted contactor you will need to pre-wire everything to the contactor before attaching the assembly to the machine. Run the battery, and switch wires down to the front of the machine where the winch is placed per the wiring instructions provided with the winch.

3. Attach all the wires to the contactor per the wiring instructions included with your winch.
4. Mount the entire winch assembly (winch, mount, contactor, and fairlead) into location and assemble using the included 8MM hardware. Shown in image below.

Note: Under the front rack there is a orange and white accessory wire that you can tap your switch into.

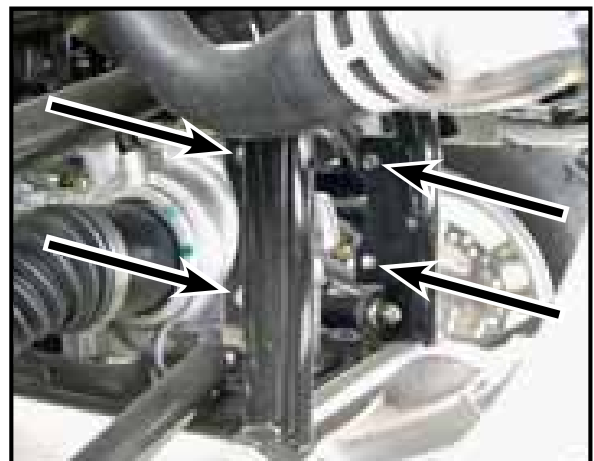

POSITION 3

1. Locate the two holes (F) “shown below” above the rear driver’s side A-arm. Mount your winch contactor to this location using the supplied ¼” x 1” bolts (6), two washers (8), and two ¼ nuts (7) or using the supplied ¼” x 1.5” self-tapping bolts (15) included. (NOTE: it is recommended to mount the contactor so that the switch wires are towards the middle of the ATV)

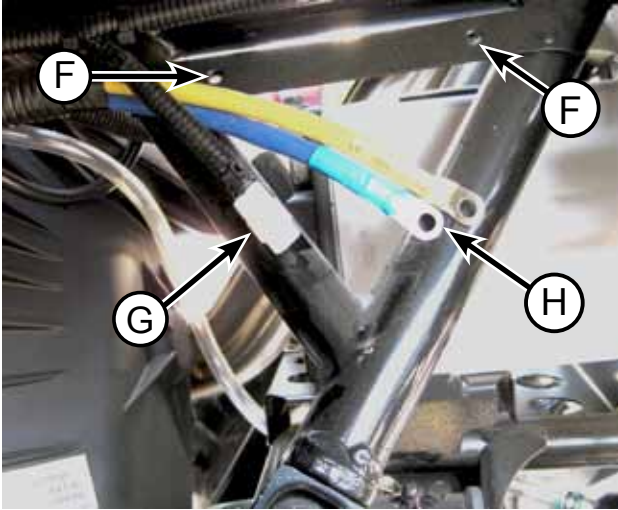

2. Slide the winch into the mount per orientation shown in [Figure 1](#). Mount your winch to the Mount using the proper hardware supplied with your winch. Don’t forget to route your winch cable through your fairlead and attach your hook. If your winch leads come close to hitting something, a lot of winches can also have the leads rotated if needed (check with your winch provider).
3. Mount the entire winch assembly (winch, mount, contactor, and fairlead) into location and assemble using the included 8MM hardware. Shown in image below.

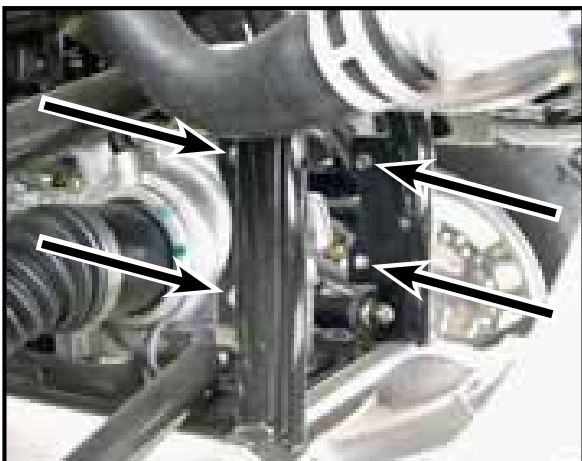

4. Connect Rocker Switch wires to the contactor. For REAR battery ATV’s you have two options:
Route the BLACK and GREEN wires all the way back to the rear mounted contactor and connect the wires.
Locate the BLACK and GREEN wire ends with a white plastic connector (D) and (G) located back by the contactor. Cut these connectors off and wire in using correct electrical connections.

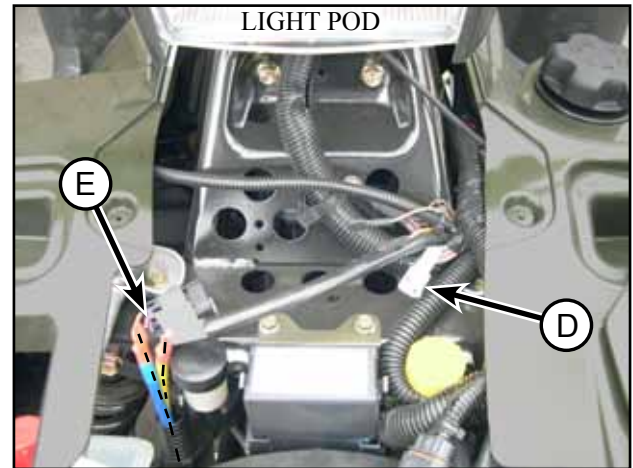

Note: Under the front rack there is a orange and white accessory wire that you can tap your switch into.

5. For REAR battery ATV’s, under the seat, locate the BLUE and YELLOW wires (H) in or near the battery Compartment. Connect the Blue and Yellow wires to the contactor. (Please refer to your winch’s wiring diagram) Next locate the YELLOW and BLUE wires (E) in the front of the ATV. Cut the zip ties that hold the wires in place, route the wires to the location of the winch leads. Remove the Red protective coverings from the wire ends and connect the cable to the appropriate lead on the winch (please refer to your winch’s wiring diagram). Finally use the shorter wires (usually Red and Black) from your winch package and connect the contactor to your battery. (Please refer to your winch’s wiring diagram)



POSITION 4

1. Locate the two holes (J) “shown below” by your radiator on the passenger side. Mount your winch contactor to this location, using the two supplied ¼” x 1.5” self- tapping bolts (15).

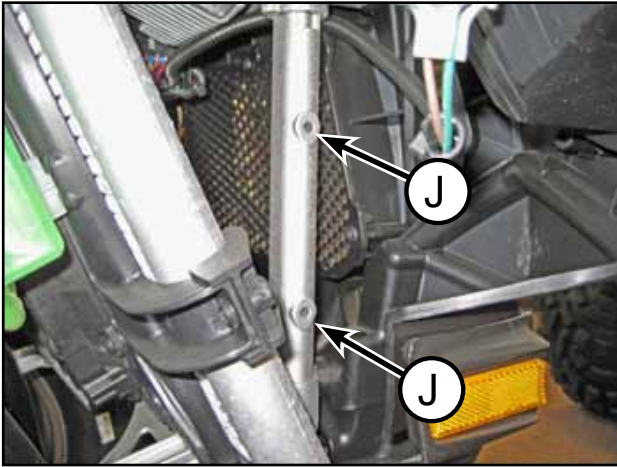

2. Slide the winch into the mount per orientation shown in [Figure 1](#). Mount your winch to the Mount using the proper hardware supplied with your winch. Don't forget to route your winch cable through your fairlead and attach your hook. If your winch leads come close to hitting something, a lot of winches can also have the leads rotated if needed (check with your winch provider).
3. Mount the entire winch assembly (winch, mount, contactor, and fairlead) into location and assemble using the included 8MM hardware. Shown in image below.

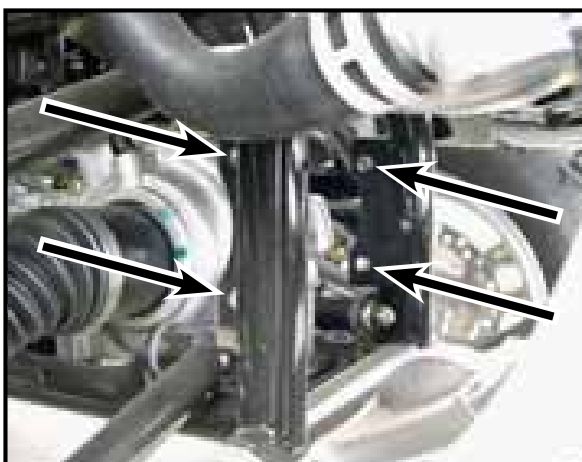

4. Wire the winch up per the instructions that came with your winch.

Note: Under the front rack there is a orange and white accessory wire that you can tap your switch into.

POSITION 5

1. Mount your Contactor to the ATV frame just above winch mount location. “Shown below” using the supplied two ¼” x 1.5” self- tapping bolts (15) or the hardware included with your winch.

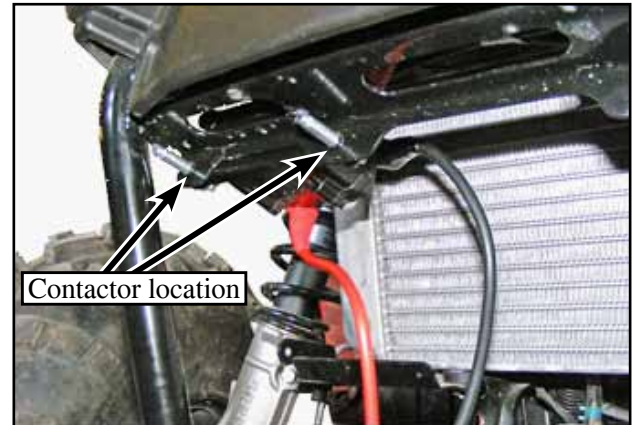

2. Slide the winch into the mount per orientation shown in [Figure 1](#). Mount your winch to the Mount using the proper hardware supplied with your winch. Don't forget to route your winch cable through your fairlead and attach your hook. Your may need to rotate your winch leads if they come close to hitting something
3. Mount the entire winch assembly (winch, mount, contactor, and fairlead) into location and assemble using the included 8MM hardware. Seen below.

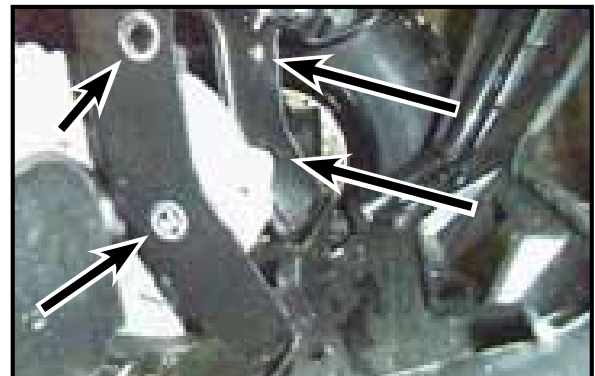

4. Wire the winch up per the instructions that came with your winch.
5. *Note: If your machine comes with pre ran battery wires (K) you can use these wires instead if the wires that came with your winch. Wire your contactor to your winch using the shortest wires included with your winch. (Do not forget to connect pre ran battery wire to the battery.) Under the front rack there is a orange and white accessory wire that you can tap your switch into.*

