

Honda Talon Lower Door

Lower Door PART # 101785

Kit Components:		
Item #	Qty.	Description
1	1	Lower Passenger Door
2	1	Lower Driver Door
3	6	Door Bracket
4	1	HK-360
4.1	6	1/4"-20 x .75 Hex Flange Bolt
4.2	6	1/4"-20 Hex Flange Nylock Nut
4.3	6	5/16"-18 x 1.00 Carriage Bolt
4.4	6	5/16"-18 Hex Flange Nylock Nut

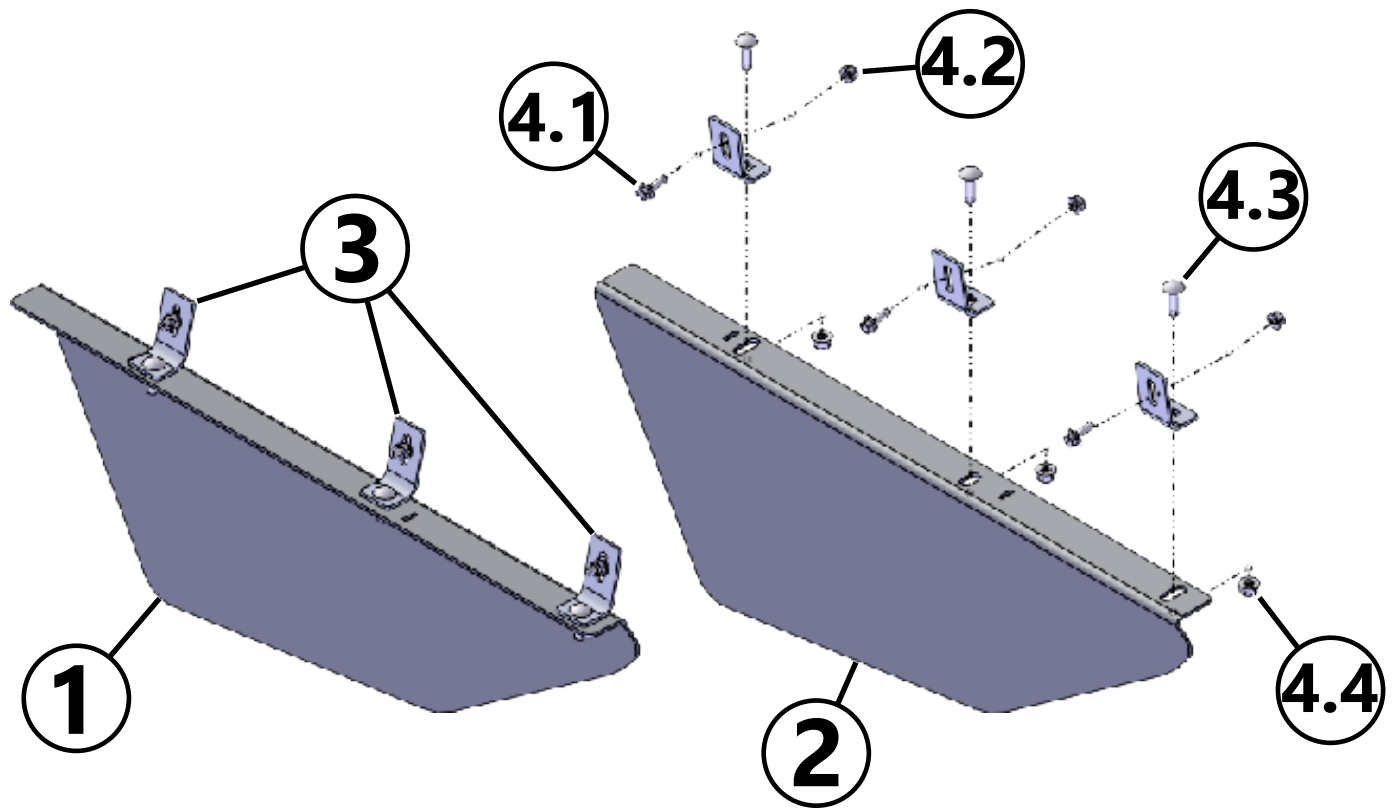

INSTALLATION INSTRUCTIONS:

Note: Make sure all hardware needed to complete this mount is in the package. Thoroughly read through and understand the instructions before installing.

Note: All steps and images shown in this manual are for the passenger side door. Steps 1-7 will be repeated for driver side door.

1. Remove the 8 phillips head screws (A) on the inner door panel and remove the outer door panel as shown in **Figure 2**. **Note:** The door will have to be closed for the outer door panel to be removed.
2. Set Door Brackets (3) in place and center the slot of the bracket up with the indents in the door panel as shown in **Figure 3 & 4**.
3. Using a 9/32" drill bit, drill a hole through the door panel using the indents in the door panel as a guide or approximately 1/2" up from the bottom of the slot in brackets (3) as shown in **Figure 4**. **Note:** On the bracket closest to the door hinge the indent will be near the bottom of the bracket slot. Do not use this indent as a guide, instead measure up 1/2" from the bottom on the bracket slot and drill the hole.
4. Once all holes are drilled through the door panel, mark the center of the square hole on the bottom flange in Bracket (3) on all brackets. Remove the Bracket (3) and drill a 11/32" hole using the mark as a guide.
5. After all holes have been drilled, set Brackets (3) back in place as shown in **Figure 3** and fasten all brackets to the door panel using Bolts (4.1) and Nuts (4.2) by inserting the bolt from the outside in as shown in **Figure 5**. **Note:** Be sure that Brackets (3) are seated down tight to the bottom of the door before tightening.
6. Once all Brackets (3) have been fastened to the door panel, hold Lower Passenger Door (1) in place and fasten using Carriage Bolt (4.3) and Nut (4.4) by inserting the bolt from the top down as shown in **Figure 5**. **Note:** Both Lower Doors are slotted and can be moved in and out to your preference.
7. Re-install door panel removed from step 1 and Tighten all hardware evenly.

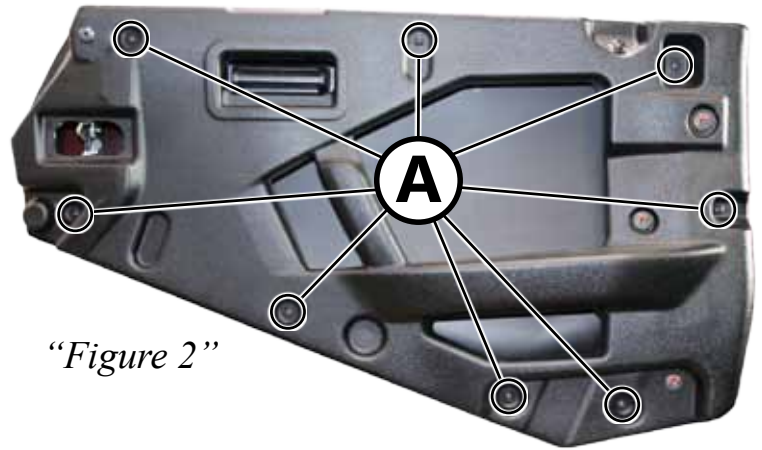

"Figure 2"

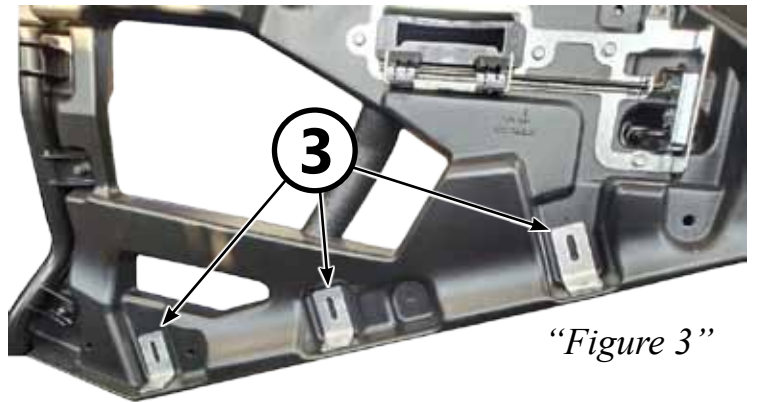

"Figure 3"

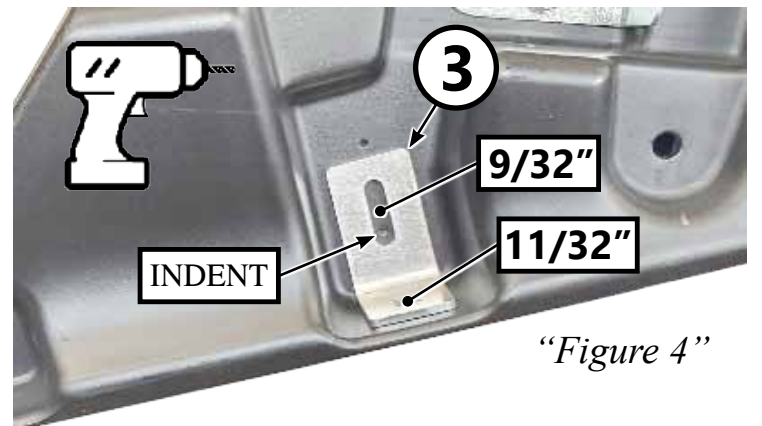

"Figure 4"

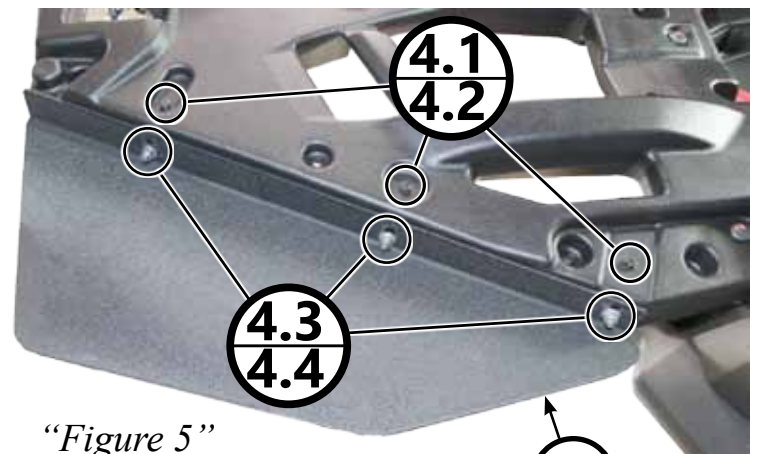

"Figure 5"