

Kawasaki Mule SX 610

Rear Receiver

PART #101820

Kit Components:		
Item #	Qty.	Description
1	1	Rear Receiver
2	1	HK-377
2.1	2	5/16"-18 x 2.00 x 2.50 SQ U-Bolt 1.25 Thread
2.2	4	5/16"-18 Hex Flange Nylock Nut
2.3	2	M8-1.25 x 30 Hex Flange Bolt
2.4	2	M8 Flat Washer
2.5	2	M8-1.25 Hex Nylock Nut

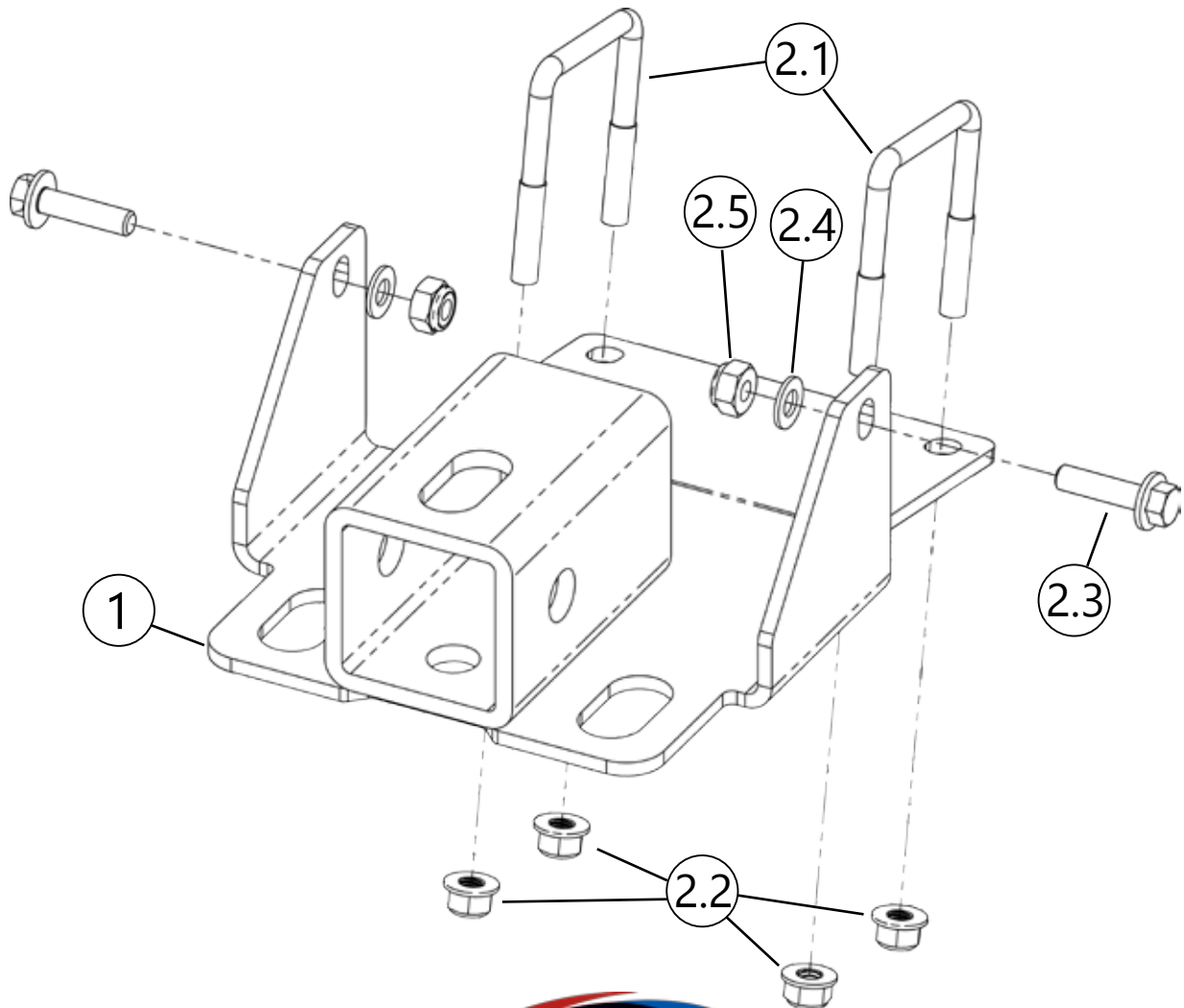

INSTALLATION INSTRUCTIONS

Note: Before proceeding, match up 5/16" hardware and M8 hardware by threading the nuts on the bolts by hand. Failure to do so could result in cross-threaded hardware. Make sure all hardware needed to complete this mount is in the package. Thoroughly read through and understand the instructions before installing.

1. Remove and discard the two OEM flange bolts (A) securing the exhaust supports to the frame as shown in **Figure 1**.

2. Hold rear receiver (1) in place and secure the front of the receiver to the exhaust supports using bolts (2.3), washers (2.4), and nuts (2.5) as shown in **Figure 2**.

Note: Bolts (2.3) will need to be threaded and tightened into the OEM nut (B) on the exhaust supports before securing washer (2.4) and nut (2.5)

3. Secure the rear of the rear receiver (1) to the frame using u-bolts (2.1) and nuts (2.2) as shown in **Figure 3**.

4. Tighten all hardware evenly.

