

POLARIS RANGER

Rear Bumper

PART #101835

Kit Components:		
Item #	Qty.	Description
1	1	Bumper
2	1	Driver Side Bracket
3	1	Passenger Side Bracket
4	2	Hanger Bracket
5	4	Bumper Tube Cap
6	1	HK-343
6.1	8	5/16"-18 x .75 Hex Flange Bolt
6.2	6	5/16"-18 x .75 Short Neck Carriage Bolt BLK
6.3	2	5/16" x 1.00 Self Threading Hex Flange Bolt (not used)
6.4	2	1/4" x .75 Self Threading Hex Flange Bolt (not used)
6.5	14	5/16"-18 Hex Flange Nylock Nut

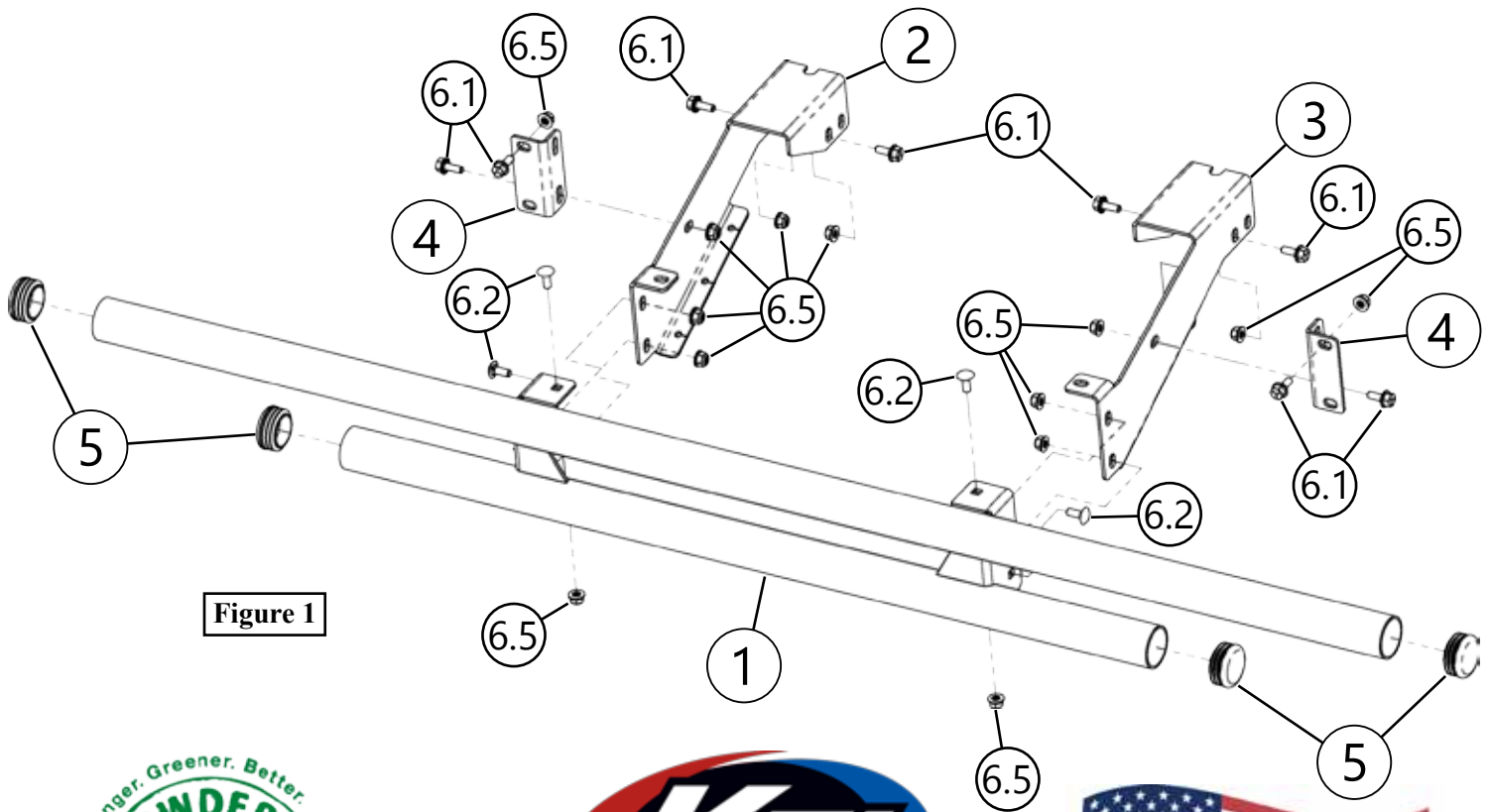

Figure 1



INSTALLATION INSTRUCTIONS

Note: Make sure all hardware needed to complete this mount is in the package. Thoroughly read through and understand the instructions before installing.

1. Assemble bumper tube caps (5) as shown in **Figure 1**.
2. Hold passenger side bumper bracket (3) in place over bed hinge and loosely fasten using bolts (6.1) and nuts (6.5) as shown in **Figure 2**.

Note: Passenger side shown. Repeat step 4 for driver side.

Note: Optional additional mounting location shown in **Figure 2**. (Hardware not included)

3. Locate the bolt strip with square cutouts (A) at the rear of the dump box underneath the tailgate as shown in **Figure 2 & 3**.
4. Position each of the hanger brackets (4) as shown in **Figure 1, 2, & 3**. Loosely bolt to bolt strip (A) using bolts (6.1) and nuts (6.5) as shown in **Figure 2 & 3**.
5. Secure hanger bracket (4) to bumper bracket using bolts (6.1) and nuts (6.5) as shown in **Figure 2 & 3**.
6. Set bumper onto bumper brackets as shown in **Figure 4**. Secure using bolts (6.2) and nuts (6.5) as shown in **Figure 5**.
7. Level bumper and tighten all hardware evenly.

