

POLARIS RANGER 570

Rear Bumper

PART #101850

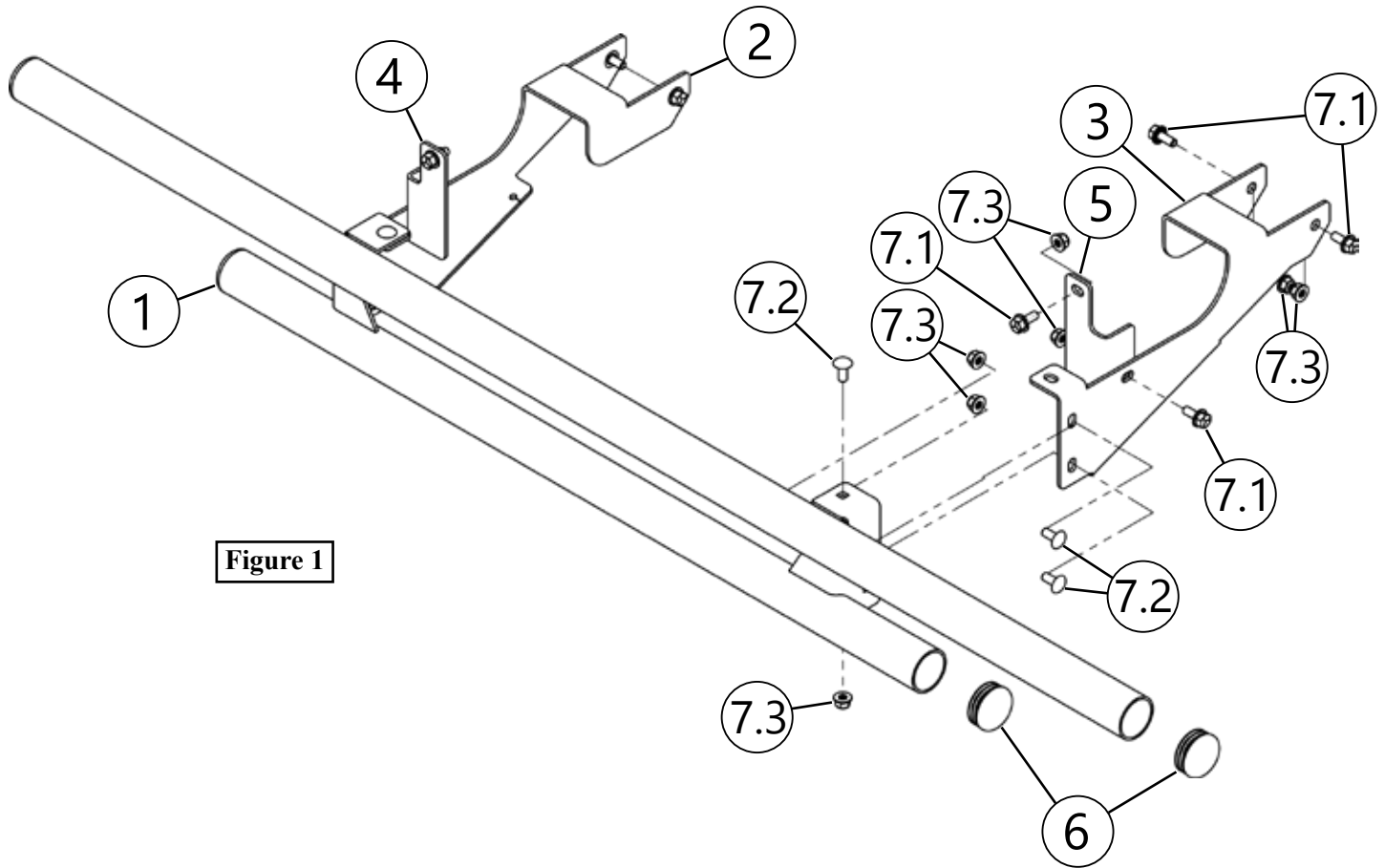

Figure 1

Kit Components:

Item #	Qty.	Description	Item #	Qty.	Description
1	1	Bumper	7.1	8	5/16" - 18 x .75 Hex Flange Bolt
2	1	Bumper Bracket Driver Side	7.2	6	5/16" - 18 x .75 Carriage Bolt (Black)
3	1	Bumper Bracket Passenger Side	7.3	14	5/16" - 18 Hex Flange Nylock Nut
4	1	Bumper Hanger Bracket Driver Side	7.4	2	1/4" x .75 Hex Flange Bolt (Thread Cutting Type) (NOT USED)
5	1	Bumper Hanger Bracket Passenger Side	7.5	2	5/16" X 1.00 Hex Flange Bolt (Thread Cutting Type) (NOT USED)
6	4	Bumper Tube Cap			
7	1	HK-343			



INSTALLATION INSTRUCTIONS

Note: Make sure all hardware needed to complete this mount is in the package. Thoroughly read through and understand the instructions before installing.

Note: Each step is for passenger side of the machine. Repeat each step for driver side.

1. Assemble tube caps (6) to bumper tubes as shown in **Figure 1**.
2. Hold passenger side bumper bracket (3) in place over bed hinge. Insert one Bolt (7.1) and Nut (7.3) on each side of bumper bracket as shown in **Figure 2**.
3. Line up hanger bracket (5) with hole in bed frame rail. Use Bolts (7.1) and Nuts (7.3) to bolt hanger brackets to the bed frame rail and bumper brackets as shown in **Figure 2**.

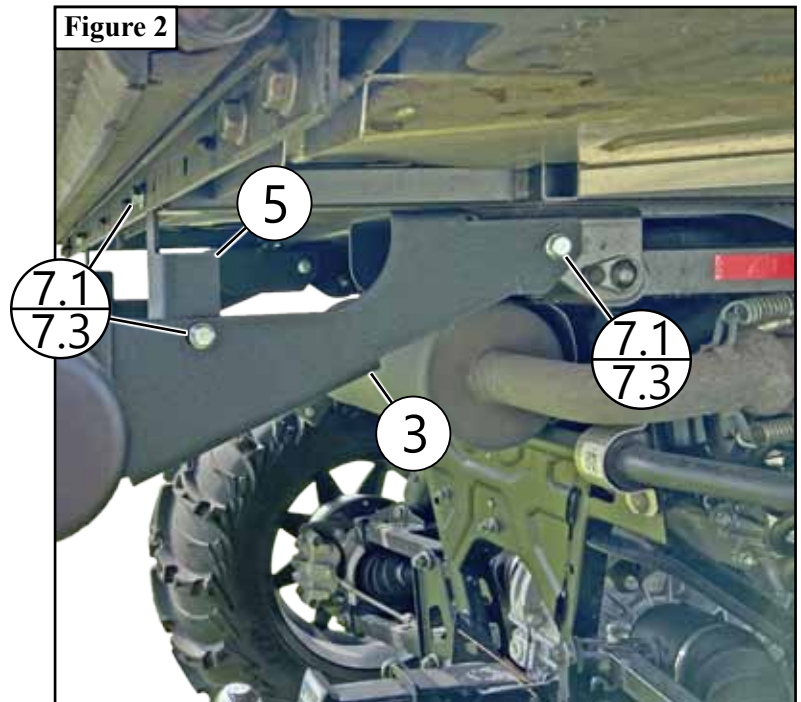

4. Bolt bumper (1) to bumper brackets (2) using Carriage Bolts (7.2) and Nuts (7.3) **Figure 3**.
5. Level bumper and tighten all hardware evenly.

