

RANGER XP 1000

Rear Bumper

PART #101900

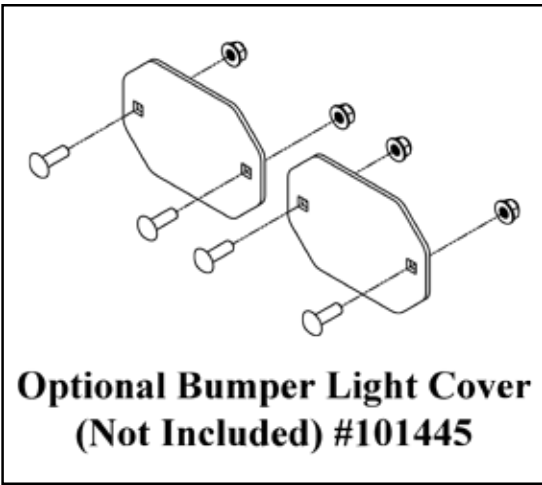
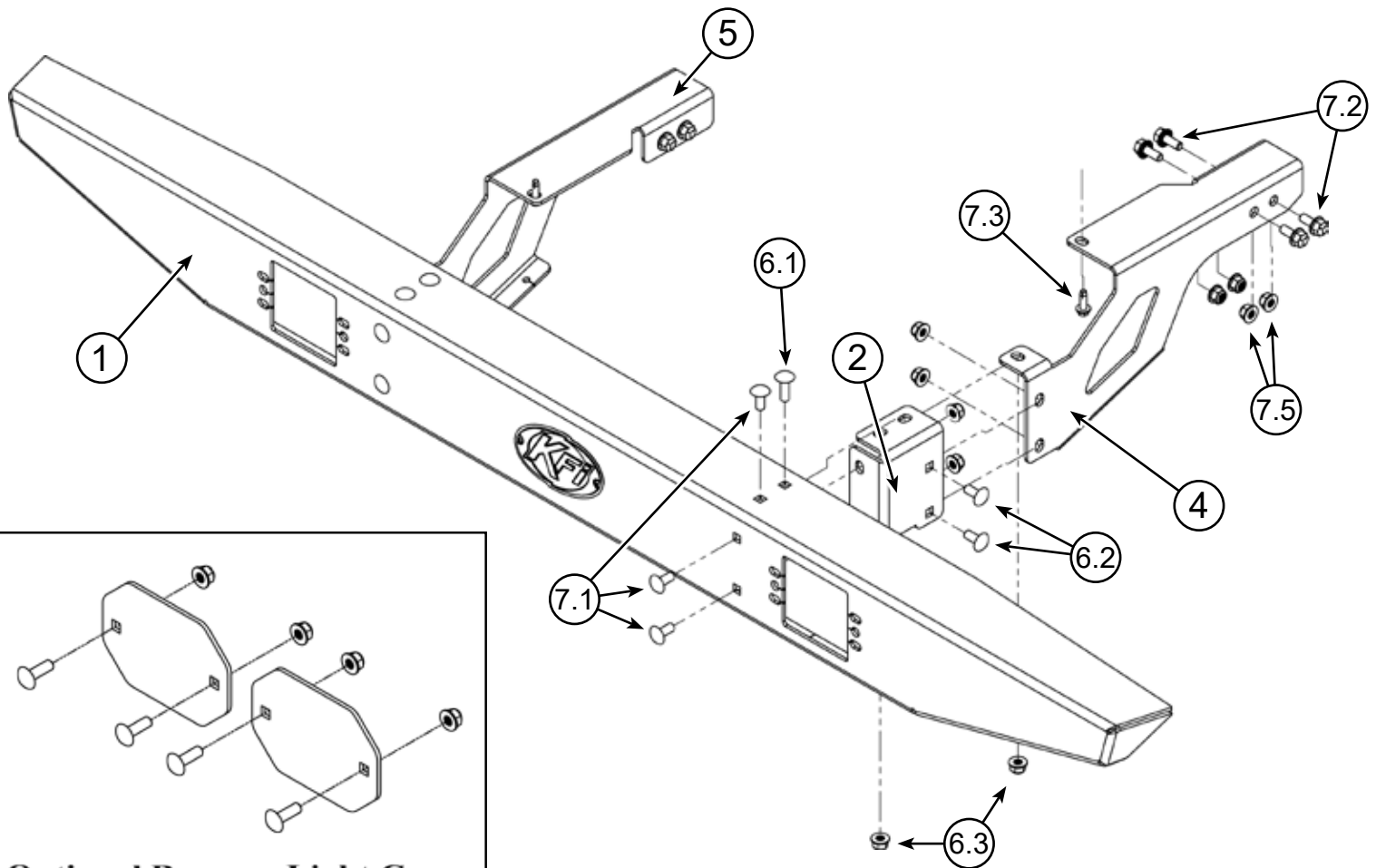

Not All Hardware Is Used

Kit Components:

Item #	Qty.	Description	Item #	Qty.	Description
1	1	Rear Bumper Formed Ranger XP1000	6.3	6	5/16"-18 Hex Nut Flange Nylock GR5
2	1	Passenger Side Conversion Bracket	7	1	Hardware Kit HK-343
3	1	Driver Side Conversion Bracket (Not Shown)	7.1	6	5/16"-18 x .75 Carriage Bolt Short Neck GR5 Black
4	1	Passenger Side Bumper Bracket	7.2	8	5/16"-18 x .75 Hex Bolt Flange GR5 Serrated
5	1	Driver Side Bumper Bracket	7.3	2	5/16"-18 x .75 Hex Bolt Flange Thread Cutting
6	1	Hardware Kit HK-342	7.4	2	1/4"-20 x .75 Hex Bolt Flange Thread Cutting
6.1	2	5/16"-18 x 1.00 Carriage Bolt Short Neck GR5 Black	7.5	14	5/16"-18 Hex Nut Flange Nylock GR5
6.2	4	5/16"-18 x .75 Carriage Bolt Short Neck GR5			



INSTALLATION INSTRUCTIONS

Note: Make sure all hardware needed to complete this mount is in the package. Thoroughly read through and understand the instructions before installing.

1. Each step must be mirrored on both sides of the machine.
2. Hold the Passenger Side Bumper Bracket (4) in place inside the bed hinge and use bolts (7.2) and nuts (7.5) to bolt the brackets to the bed hinge as shown in **Figures 1 & 2**. Repeat this step for the Driver Side Bumper Bracket (5).
3. Once both Bumper Brackets are in place, use the 5/16" self tapping screw (7.3) to secure the rear portion of the Bumper Bracket. This screw should be hand tightened only or you could strip it out. See **Figure 2**.
4. To assemble bumper, locate the Formed Bumper (1) and Conversion Brackets (2 & 3). Install the Conversion Brackets onto the inside of the Formed Bumper with 3 black carriage bolts (7.1) and lock nuts (6.3) per side as shown at the top of **Figure 3**.
5. Set the Bumper Assembly onto the Bumper Brackets (4 & 5) and secure using bolts (6.1 & 6.2) and nuts (7.5) as shown in the bottom of **Figure 3**.
6. Level bumper and tighten all hardware evenly.

