

HONDA PIONEER 1000

Winch Mount

PART #101965

| Kit Components: | | |
|-----------------|------|--------------------------------|
| Item # | Qty. | Description |
| 1 | 1 | Winch Mount |
| 2 | 1 | Fairlead Adapter Mount |
| 3 | 1 | HK-031 |
| 4 | 1 | HK-403 |
| 4.1 | 1 | 3/8"-16 x 1.00 Hex Flange Bolt |
| 4.2 | 1 | 3/8"-16 Hex Flange Nylock Nut |

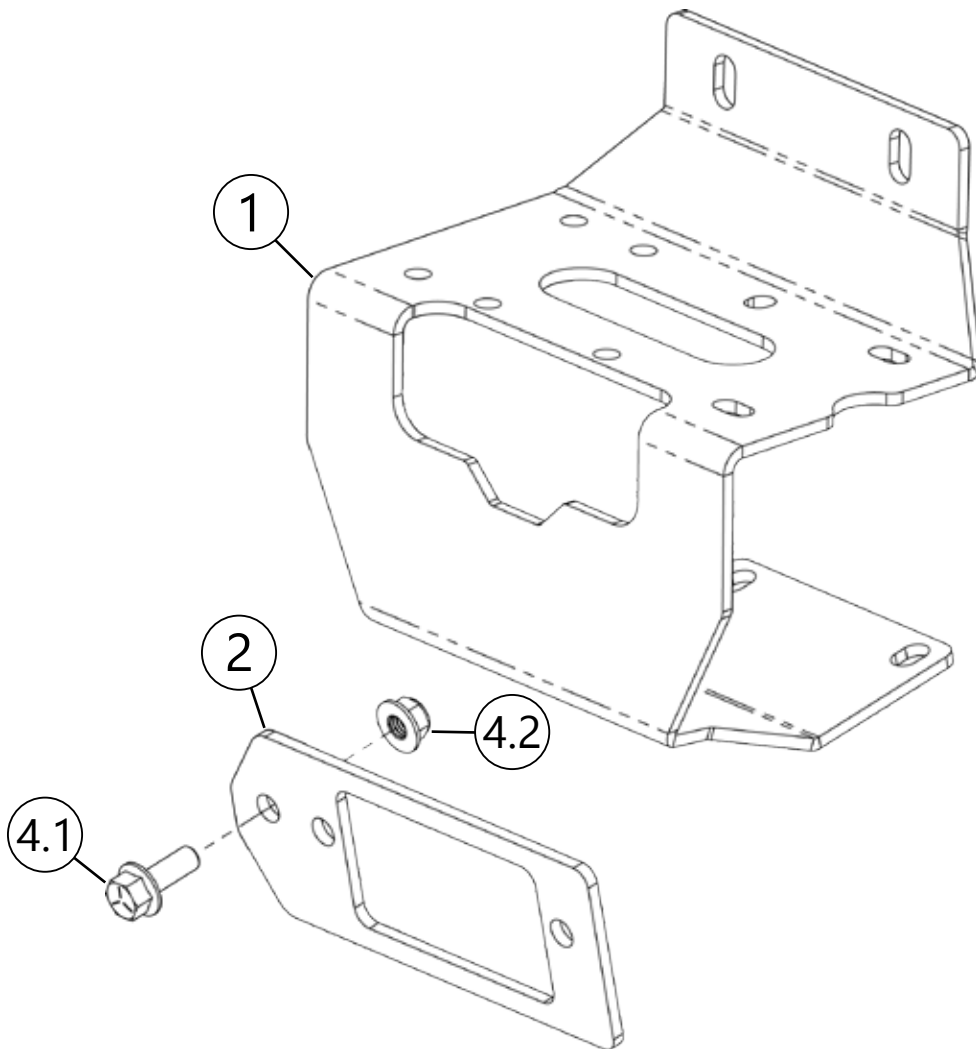

INSTALLATION INSTRUCTIONS

Note: Make sure all hardware needed to complete this mount is in the package. Thoroughly read through and understand the instructions before installing.

1. Remove the two cap screws (A) holding the plastic to the bumper and the two bottom bolts (B) as shown in **Figure 1 & 2**. Remove bolts (C) holding the bumper tube supports to the frame as shown in **Figure 2** and remove bumper.

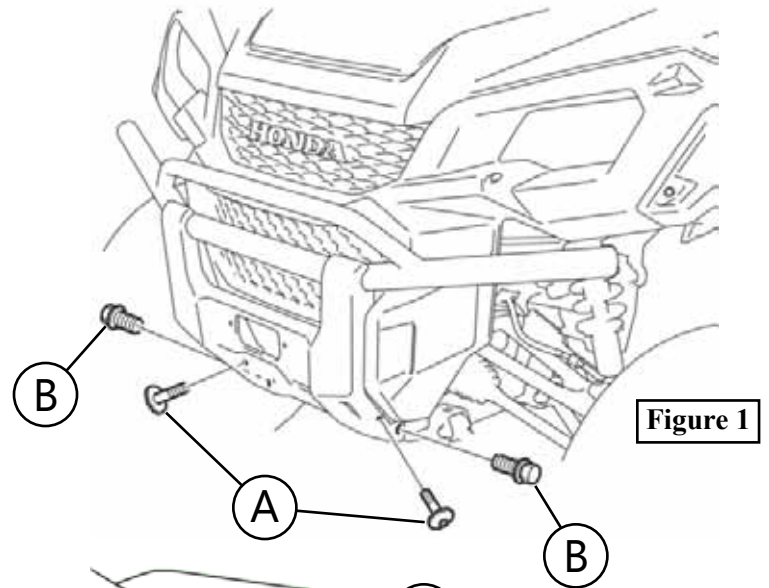

2. Remove differential bracket bolts (D) as shown in **Figure 3**.

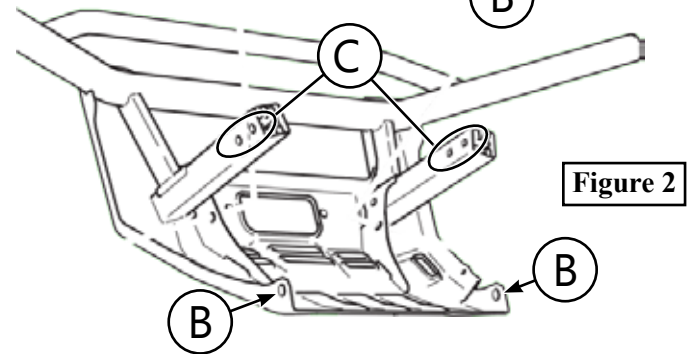

3. Set winch mount (1) in place and secure to the differential brackets using OEM bolts (D) as shown in **Figure 4**.

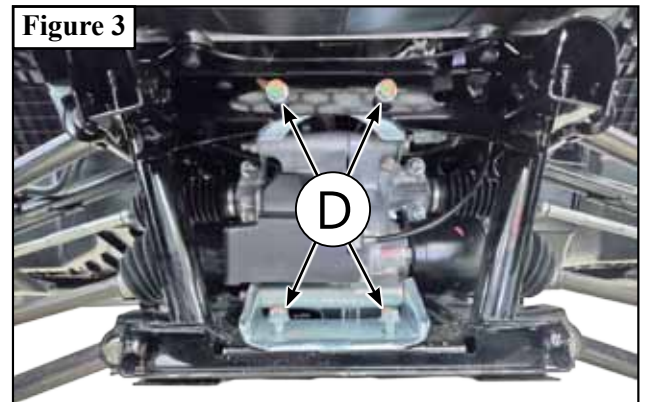

4. Install winch into winch mount (1) using hardware supplied with winch and routing winch cable as shown in **Figure 5**.

Note: Winch will be installed upside down on the winch mount. Winch cable will need to come out between the winch mount and the spool of the drum (Bottom Of The Winch) as shown in Figure 5.

Note: See **Figure 6** for winch mounting locations.

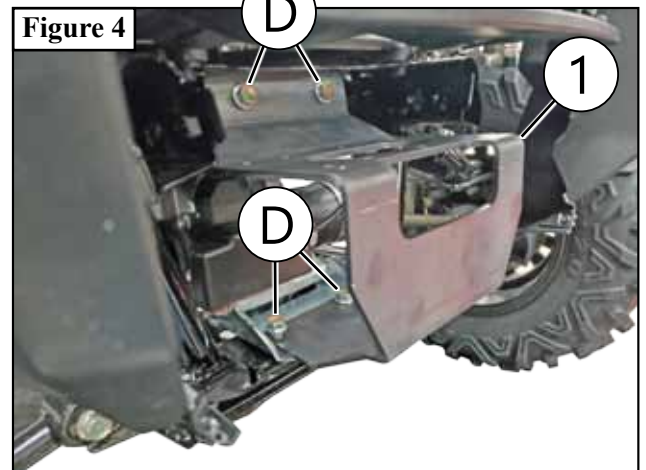
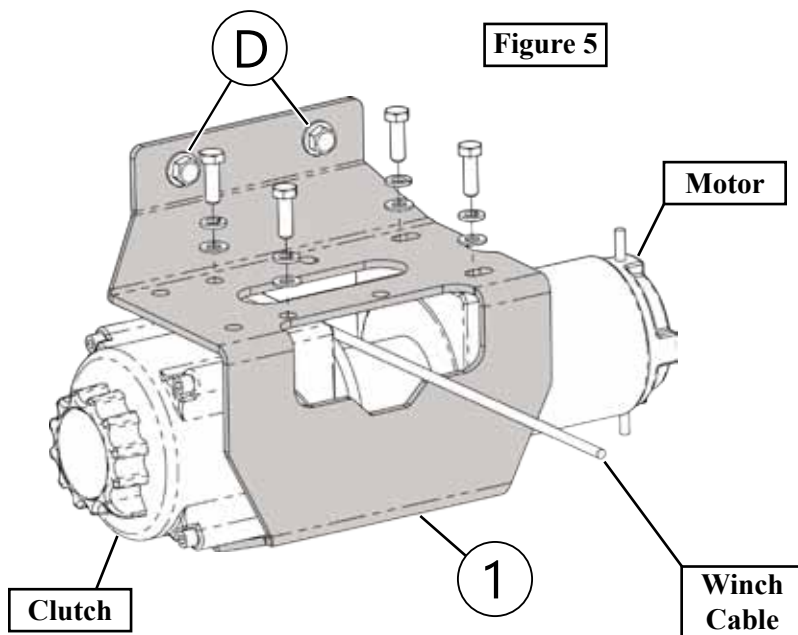

INSTALLATION INSTRUCTIONS

5. Attach Fairlead to the front bumper.

- **Standard Fairlead (4.875") bolt pattern**

Attach the fairlead adapter mount (2) to the passenger side of the front bumper using bolt (4.1) and nut (4.2) as shown in **Figure 7 & 8**.

- **Wide Fairlead (6.00") bolt pattern**

Attach the fairlead directly to the bumper as shown in **Figure 9** using the hardware supplied with the winch.

6. Rotate the clutch cap on the winch to the "Free Spool" position and pull 2-3 feet of cable out. Feed the cable through the fairlead mounted to your bumper.

7. Re-install the front bumper using bolts (A, B, and C) removed in steps 1 and 2.

8. Tighten all hardware evenly

Figure 6

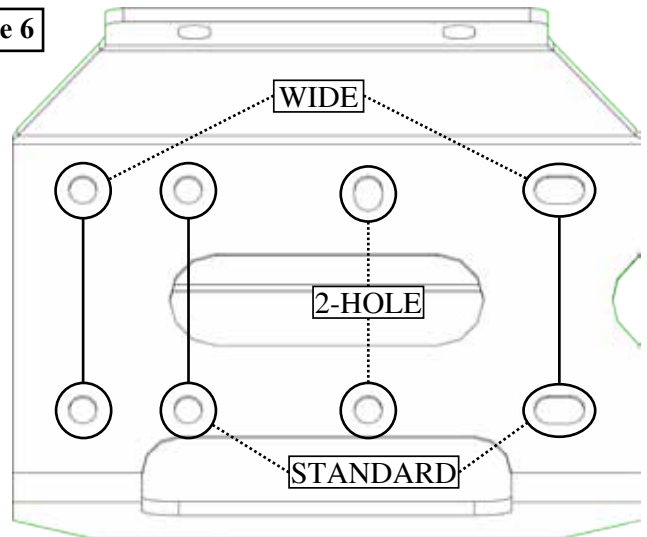

Figure 7



Figure 8



Figure 9



WIRING INSTRUCTIONS

9. To make routing wires and installing the contactor easier, temporarily reposition the coolant overflow tank by lifting/pulling it up to pop it out of its bracket shown in **Figure 10**.

10. Mount contactor in suggested location as shown in **Figure 11**. Mark holes, drill, and attach contactor using hardware supplied with the winch.

11. Rocker Switch -red/power wire:

- Unclip the fuse panel from the body as shown in **Figure 10 & 12**. Locate the white wire with black stripe next to the heavy red power wire as shown in **Figure 12**.

Note: The keyed power wire may be red with a black stripe on some machines.

Verify the wire is ignition controlled by using a test light. Test light should only illuminate when key is on.

- Connect the red wire from your switch to the white with black stripe ignition-controlled power wire using the quick connector supplied with the winch.

12. Wire accordingly using the wiring instructions supplied with the winch.

Note: For 2017 - Current Pioneers, discard the battery ground (-) cable supplied with the winch, remove the blue tape on the pre-ran OEM ground (-) cable shown in **Figure 14** and connect to the contactor.

