

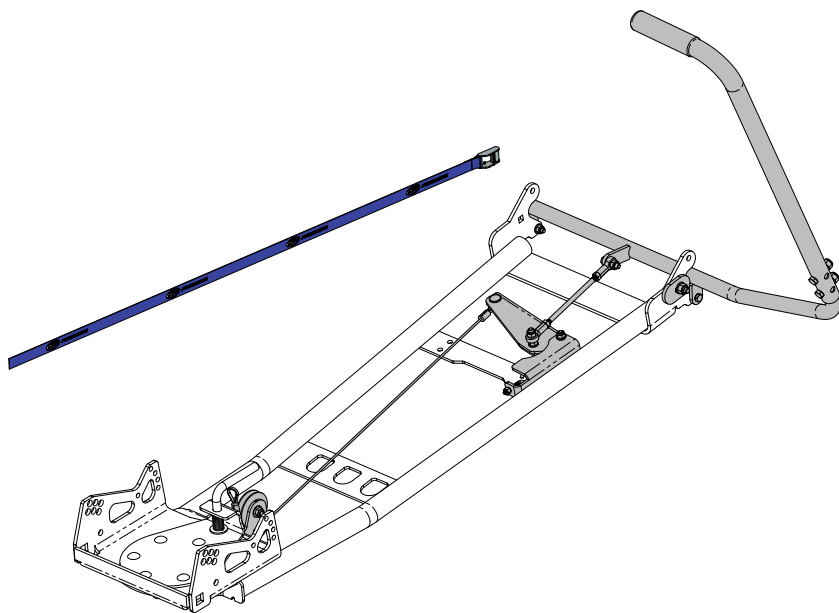

Instruction Manual



ATV Manual Plow Lift

Safety Rules

Manual Conventions

This manual uses the following symbols to help differentiate between different kinds of information. The safety symbol is used with a key word to alert you to potential hazards in operating and owning a plow.

Follow all safety messages to avoid or reduce the risk of serious injury or death.

WARNING

- Read this manual thoroughly before operating your manual lift. Failure to follow instructions could result in serious injury or death.
- Do not exceed 5 mph, even with blade raised.
- Make sure that all nuts and bolts are tightened per installation instructions.
- Never operate this KFI product with missing or damaged parts.
- Drive slowly over bumpy and rough terrain, driving fast could cause damage to manual lift or plow.
- Never raise the plow above point of contact as it could cause damage to machine, manual lift or plow.
- Always perform regular inspections and maintenance on hardware before use.
- Operate with extreme caution on slopes, steep grades, and rough terrain.
- Be aware of any possible hidden objects under the snow.
- Do not ram the blade into the pile.

CAUTION

CAUTION indicates a potentially hazardous situation which, if not avoided, may result in minor or moderate injury.

CAUTION

CAUTION used without the safety alert symbol indicates a potentially hazardous situation which, if not avoided, may result in property damage.

DANGER

DANGER indicates an imminently hazardous situation which, if not avoided, will result in death or serious injury.

WARNING

WARNING indicates a potentially hazardous situation which, if not avoided, could result in death or serious injury.

NOTE

If you have questions regarding your manual lift system, we can help. Please call our help line at 1-877-346-2050.

CAUTION

- Take care when installing SPRINGS as they will be under tension.
- Use care when lifting components into place.

DANGER

Never stand or ride on the plow.

To help you make informed decisions regarding safety, we have included instructions and information on labels. This information is provided with the intent to help avoid potential hazards that may harm you or others. It is, in no way, possible for us to inform you of every hazard you may come across with this product.



1 Year Limited Warranty

Kappers Fabricating, Inc. (KFI) warrants to the original purchaser that the product is free from defects in materials and workmanship for a period of one (1) year from the original date of purchase. We will repair or replace, at our discretion, parts found to be defective due to materials or workmanship. This warranty is subject to the following limitations and exclusions:

Commercial Use: The warranty period for any product used for commercial or rental is limited to ninety (90) days from the date of original purchase.

Limitations: This warranty applies only to products which have been properly assembled, adjusted, and operated in accordance with the instructions contained within this manual. This warranty does not apply to any product of Kappers Fabricating, Inc. that has been subject to alteration, misuse, abuse, improper assembly or installation, or shipping damage.

Exclusions: Excluded from this warranty are normal wear, normal adjustments, and normal maintenance.

THIS WARRANTY DOES NOT APPLY TO ANY INCIDENTAL OR CONSEQUENTIAL DAMAGES AND ANY IMPLIED WARRANTIES ARE LIMITED TO THE SAME TIME PERIODS STATED HEREIN FOR ALL EXPRESSED WARRANTIES.

THE WARRANTY SET FORTH ABOVE IS THE ONLY WARRANTY. THERE ARE NO OTHER WARRANTIES, EXPRESS OR IMPLIED, INCLUDING BUT NOT LIMITED TO IMPLIED WARRANTIES OF MERCHANTABILITY OR FITNESS FOR A PARTICULAR PURPOSE.

Some states do not allow the exclusion of implied warranties or the exclusion or limitation of liability for incidental or consequential damages, or limitations on how long an implied warranty lasts, so the above limitation or exclusion may not apply to you. This warranty gives you specific legal rights. You may also have other rights that vary from state to state.

In the event you have a claim under this warranty, contact KFI's Technical Service and KFI will troubleshoot any issue via phone or e-mail. If the problem is not corrected by this method, KFI will, at its option, authorize evaluation, repair or replacement of the defective part or component at a KFI Service Center. KFI will provide you with a case number for warranty service. Please keep it for future reference. Repairs or replacements without prior authorization, or at an unauthorized repair facility, will not be covered by this warranty.

All transportation charges, damage, or loss incurred during transportation of parts submitted for replacement or repair under this warranty shall be borne by the purchaser. Should you have any questions concerning this warranty, please contact us toll-free at 1-877-346-2050. The model number, serial number (If applicable), date of purchase, and the name of the authorized KFI dealer from whom you purchased the product will be needed before any warranty claim can be processed.

For warranty inquiries outside the U.S.A. and Canada, contact your local dealer/distributor.

For countries not covered by a local dealer/distributor, please contact us at www.kfiproducts.com.

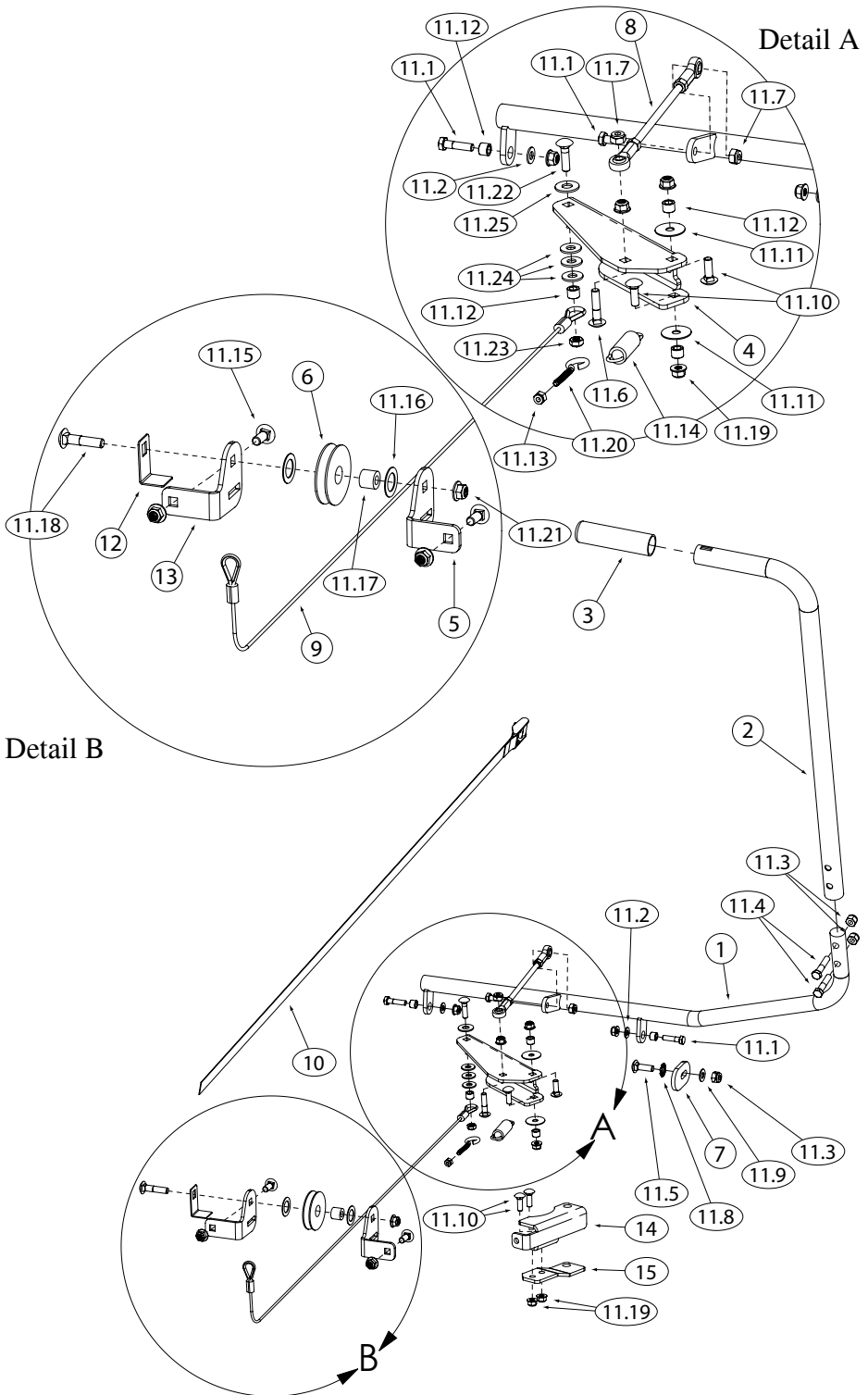

ATV Manual Plow Lift 105015 Parts List

ITEM	PART#	DESCRIPTION	QTY.
1	105178	MANUAL LIFT LOWER ARM WELDMENT	1
2	105175	MANUAL LIFT UPPER ARM	1
3	P800284	MANUAL LIFT GRIP	1
4	105171	MANUAL LIFT SWING BRACKET	1
5	105778	MANUAL LIFT PULLEY BRACKET -RH	1
6	P800280	PULLEY	1
7	105179	MANUAL LIFT SLOTTED STOP	1
8	P800281	ROD END LINKAGE	1
9	105173	MANUAL LIFT CABLE	1
10	P800286	MANUAL LIFT STRAP	2
11	HK-101	MANUAL LIFT HARDWARE KIT	1
11.1	HC-G5-ZP-0313-18-1_25	5/16-18 x 1 1/4 HEX CAP SCREW	3
11.2	FW-SAE-ZP-0313	5/16 FLAT WASHER	2
11.3	HNNL-ZP-0375-16	3/8-16 NYLOCK NUT	3
11.4	HC-G5-ZP-0375-16-1_75	3/8-16 x 1 3/4 HEX CAP SCREW	2
11.5	CB-ZP-0375-16-1_25	3/8-16 x 1 1/4 CARRIAGE BOLT	1
11.6	CB-ZP-0313-18-1_50	5/16-18 x 1 1/2 CARRIAGE BOLT	1
11.7	HNNL-ZP-0313-18	5/16-18 NYLOCK NUT	2
11.8	LW-INEX-ZP-0500	3/8" LOCK WASHER, INTERNAL/EXTERNAL TOOTH	1
11.9	FW-SAE-ZP-0375	3/8 FLAT WASHER	1
11.10	CB-ZP-0313-18-1_00	5/16-18 x 1.00 CARRIAGE BOLT	4
11.11	FEND-ZP-0313-1_25	5/16 x 1.25 FENDER WASHER	2
11.12	P800279	MANUAL LIFT BUSHING	5
11.13	HNNL-ZP-0250-20	1/4-20 HEX NYLOCK NUT	1
11.14	P800283	MANUAL LIFT SPRING	1
11.15	CB-ZP-0375-16-1_00	3/8-16 x 1.00 CARRIAGE BOLT	2
11.16	P800311	1.25 x .78 x .04 SPACER	2
11.17	P800327	PLOW PULLEY BUSHING	1
11.18	CBSN-ZP-0375-16-1_75	3/8-16 x 1-3/4 CARRIAGE BOLT	1
11.19	HNFN-ZP-0313-18	5/16-18 FLANGE NYLOCK NUT	8
11.20	P800282	1/4-20 x 1 1/2 x 1 3/8 EYEBOLT	1
11.21	HNFN-ZP-0375-16	3/8"-16 HEX NYLOCK FLANGE NUT	3
11.22	CB-ZP-0313-18-1_25	5/16"-18 X 1.25" SQ NECK CARRIAGE BOLT	1
11.23	HNNYJZ-0313-18	5/16-18 NYLOCK JAM HEX NUT	1
11.24	FW-USS-0313	5/16" USS FLAT WASHER	4
11.25	FW-USS-038	3/8" USS FLAT WASHER	1
12	105219	MANUAL LIFT CABLE KEEPER	1
13	105774	MANUAL LIFT PULLEY BRACKET - LH	1
14	105661	MANUAL LIFT TUBE BRACKET	1
15	105664	MANUAL LIFT TUBE BRACKET	1

ATV Manual Plow Lift Installation Instructions

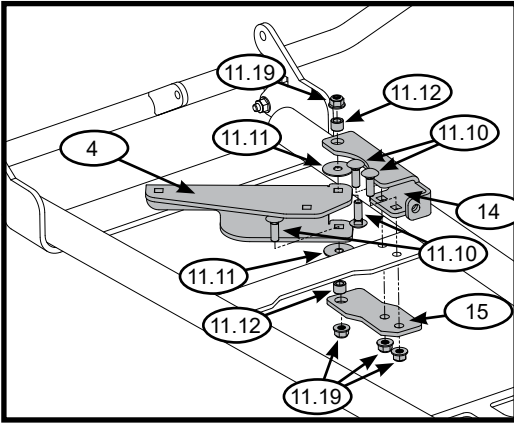

“Figure 1” Swing Bracket Install

1. Place the Manual lift tube bracket (14) on top of the push tube frame and place the manual lift tube bracket (15) below the push tube frame as shown in “Figure 1”. Insert two 5/16 x 1” carriage bolts through manual lift bracket (15), push tube frame, and manual lift bracket (14). Attach and tighten two 5/16” flange nylock nuts to the carriage bolts.

Position the swing bracket (Item 4) in the push tube assembly as shown in Figure 1. Install the bottom 5/16 x 1” carriage bolt (Item 11.10). Insert fender washer (Item 11.11) between the swing bracket (Item 4) and the manual lift bracket (item 1). Install the bushing (Item 11.12) over the carriage bolt from the bottom and against the washer. Install the 5/16” lock nut (Item 11.19) and tighten fully. Do the same for the upper portion.

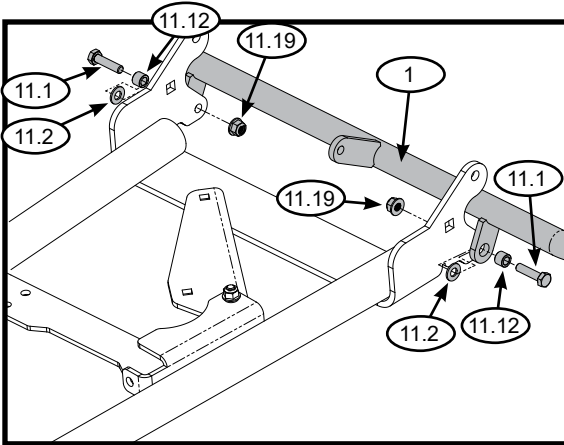

“Figure 2” Lower Arm Install

2. Position the lower arm (Item 1) behind the push tube assembly as shown in Figure 2 and install two 5/16” x 1-1/4” bolts (Item 11.1), bushings (Item 11.12), flat washers (Item 11.2), and nylock flange nuts (Item 11.19). The flat washers are used as spacers between the lift handle tabs and the push tube tabs as needed.

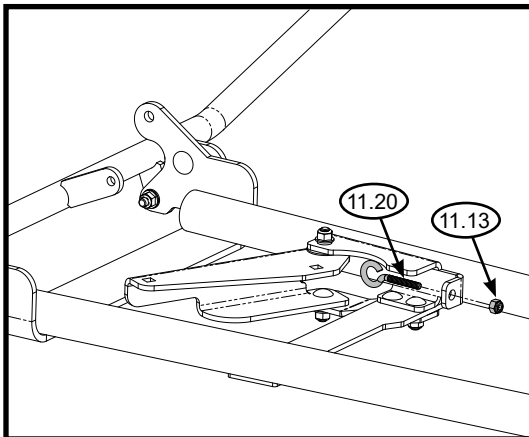

“Figure 3” Spring Adjustment Install

3. Loosely install the 1/4” eyebolt (Item 11.20) and nut (Item 11.13) into the tab on the manual lift assembly.

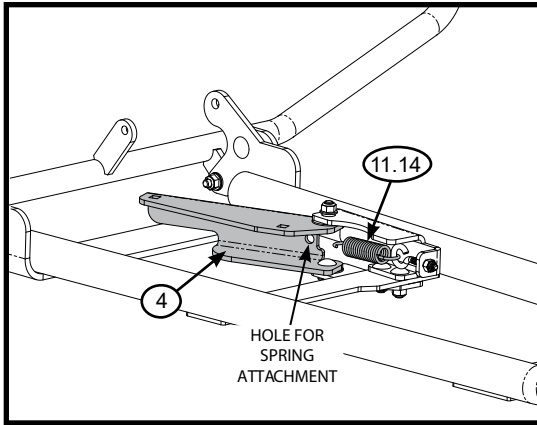

“Figure 4” Spring Install

4. Hook the manual lift spring (Item 11.14) to the hole in the swing bracket (Item 4), using a pliers stretch the spring to the eyebolt and hook it on. Tighten the nut on the eyebolt about half way.

Note: spring tension may need to be adjusted later.

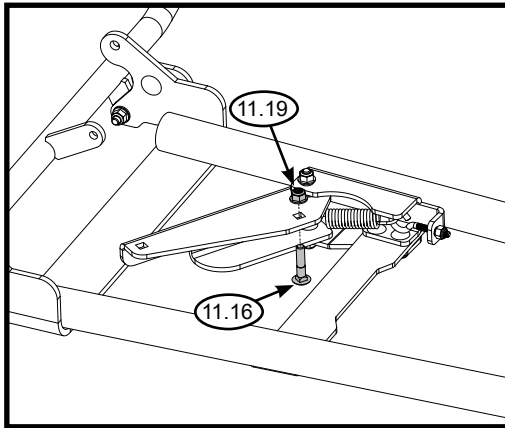

“Figure 5” Rod End Linkage Hardware Install

5. Assemble the 5/16” x 1 1/2” carriage bolt (Item 11.6) and nylock flange nut (Item 11.19) for the rod end linkage to the swing arm bracket (Item 4) as shown in Figures 5&6 and tighten.

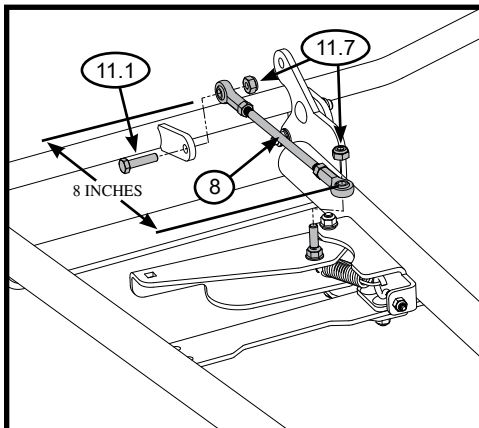

“Figure 6” Rod End Linkage Install

6. Using a ruler or tape measure adjust the length of the rod end linkage to 8”, measured from hole to hole.
7. Install one end of the rod end linkage to the swing arm bracket using the 5/16” nylock nut (Item 11.7) as shown in Figure 6 and tighten nut.
8. Install the other end of the rod end linkage to the left side of the tab on the lower arm using the 5/16” x 1 1/4” bolt (Item 11.1) and 5/16” nylock nut (Item 11.7) as shown in Figure 6 and tighten nut.

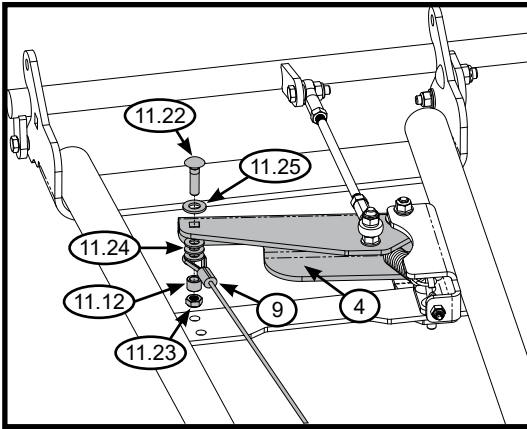

“Figure 7” Cable Install

9. Place the 3/8” washer (11.25) on the top of the swing bracket. Place the carriage bolt (11.22) through the washer and bracket. Place three 5/16” washers (11.24) onto the carriage bolt on the bottom side. Slide the copper bushing (11.12) onto the carriage bolt below the three washers, then slide the cable (9) over the bushing. Tighten the 5/16” nylock (11.23) nut into place.

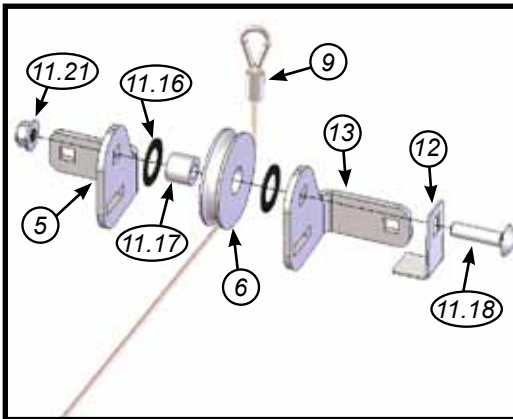

“Figure 8” Pulley Assembly

10. Assemble the wire guide (Item 12), cable (Item 9), pulley bracket-right (Item 5), pulley bracket-left (Item 13), spacers (Item 11.16), bushing (Item 11.17), and pulley (Item 6) using the 3/8” x 1 1/2” carriage bolt and 3/8” nylock flange nut as shown in Figure 8.

Note: Do not over tighten or pulley wont turn freely. Cable (Item 9) must be installed to wire guide (Item 12) at this point.

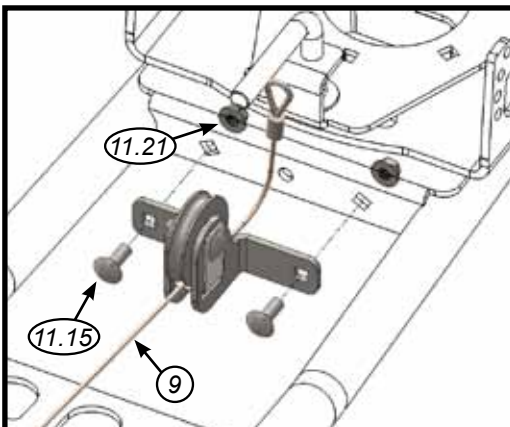

“Figure 9” Pulley Assembly Install

11. Install the pulley assembly to the tube system using the 3/8” x 1” carriage bolts (Item 11.15) and 3/8” nylock flange nuts (Item 11.21) supplied with your hardware kit as shown in Figure 9. **Position the cable (Item 9) behind the pulley at the time of assembly or it wont fit through the opening.**

Note: in most cases the hook plate (see ATV push tube manual) will have to be removed in order to install the pulley assembly.

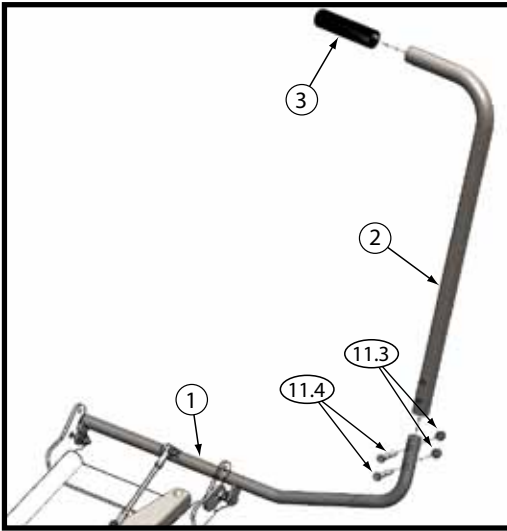

“Figure 10” Upper Arm Install

12. Install the upper arm (Item 2) to the lower arm (Item 1) using the 3/8” x 1 3/4” bolts (Item 11.4) and 3/8” nylock nuts (Item 11.3) as shown in Figure 10.

13. Place the handle grip (Item 3) on the end of the upper arm (Item 2) as shown in Figure 10 and rotate until logo is in desired position.

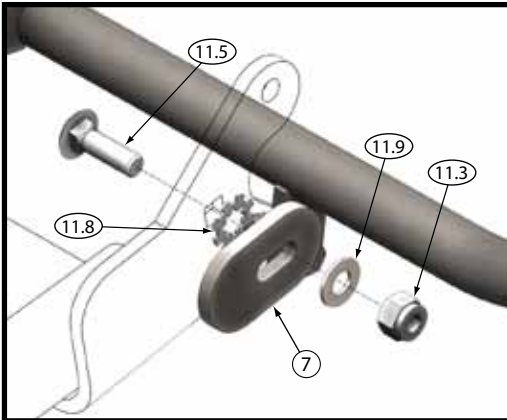

“Figure 11” Slotted Stop Install

14. Finally install the slotted stop (Item 7), flatwasher (Item 11.9), 3/8” x 1 1/4” carriage bolt (Item 11.5), star washer (Item 11.8) and 3/8” nylock nut (Item 11.3) in the square hole on the left tab of the tube frame.

15. See Page 10 for vehicle install and adjustments.

ATV Manual Plow Lift Adjustment and Mounting Guide



“Figure 12” Manual Lift Install

Mounting the manual lift.

1. Position the tube frame under the ATV. You can simply drive the ATV over the lift handle. Stop the ATV in a position that places the tube system tabs under the mount plate.
2. Attach the tube system to the mount plate using the clevis pins and hair pins provided with the hardware kit.
3. Position the lift strap through the loop in the cable and around a secure portion on the front of your atv.

Note: The lift strap needs to be secured to the ATV in such a manner that it will support the blade and as close to straight above the pulley as possible. We suggest attaching the lift strap to a bumper or a rack.

Adjusting the Manual Lift

1. Place the front tires on a 1-1/2” board.
2. To adjust the lift handle push the lift handle forward to a point that is about a 1/2 inch from contacting the fender, or rack, which ever comes first. Position the slotted stop (Figure 11 & 14) against the lower lift handle and tighten the 3/8” x 1-1/2” carriage bolt securely.
3. With the lift handle still in the forward position, pull the slack out of the cable by pulling the strap tight.
4. Lift the blade using the lift handle. The unit should “lock” in the up position just as the lift handle comes near the rear fender. If the lift handle does not lock before it reaches the fender, the rod end linkage needs to be shortened. If the lift handle stops short of the rear fender, the rod end linkage needs to be lengthened as in install step 6. Each time the link rod is adjusted, the strap length will have to be reset. When you have the “lock” in the up position set, remove the blocks from under the tires.



“Figure 13” Slotted Stop Install



“Figure 14” Slotted Stop Adjustment

Product Registration

Please register your product with Kappert's Fabricating, Inc. (KFI) within fifteen (15) days of purchase to assist us in handling any warranty issues that may arise by filling out this Registration card and submitting it with a copy of your sales receipt from one of KFI's official resellers. Failure to complete and return this Registration card does not diminish your warranty rights. Please refer to the above section for complete terms of this warranty.

WARRANTY IS NON-TRANSFERABLE

Please Print Clearly

Model # _____

Name _____

Street Address _____

City _____ State _____ Zip Code _____

Phone _____ Fax _____ Email _____

Date of Purchase _____ Authorized KFI Dealer Name _____

Fill out and send this section to:
KFI Products
Warranty Registration Department
721 Sata Drive, PO Box 32
Spring Valley, MN 55975, U.S.A.



KFI Products

721 Sata Drive
Spring Valley, MN 55975

1-877-346-2050