

# NEW HOLLAND 120/125 OR CASE SCOUT XL

Plow Mount                      PART # 105435  
Hardware Kit: HK-140

## Kit Components:

Qty.	Part Description
1.....	Plow Mount Plate
2.....	3/8" x 3" Hex Bolt
2.....	3/8" Flanged Nylock Nut
2.....	3/8" Flat Washer
2.....	M10 x 30mm Flanged Hex Bolt

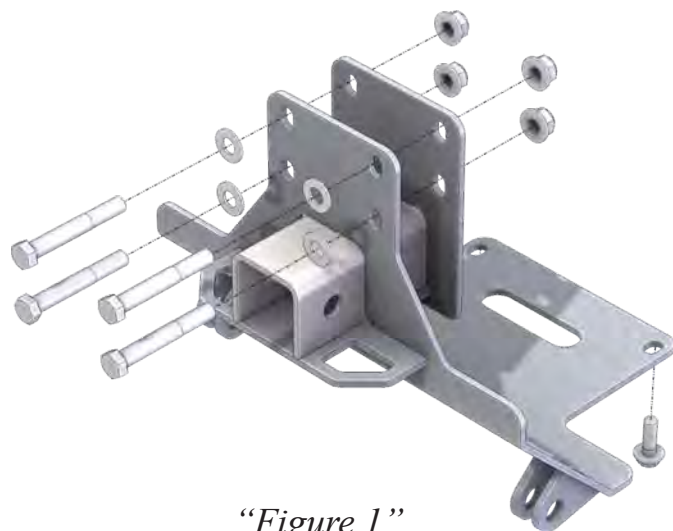

“Figure 1”

## INSTALLATION INSTRUCTIONS:

1. Remove all bolts (A) shown in Figure 2. If you have a skid plate installed this will remove it.
2. To fully remove the front plastic fascia you will need to loosen the remaining screws (B) and (C) as shown in Figure 3. Disconnect the light pods by uncoupling the spade connectors.

*Note: (B) is located behind the light pod and under the plastic fender. (C) is located under the hood in front of the radiator.*

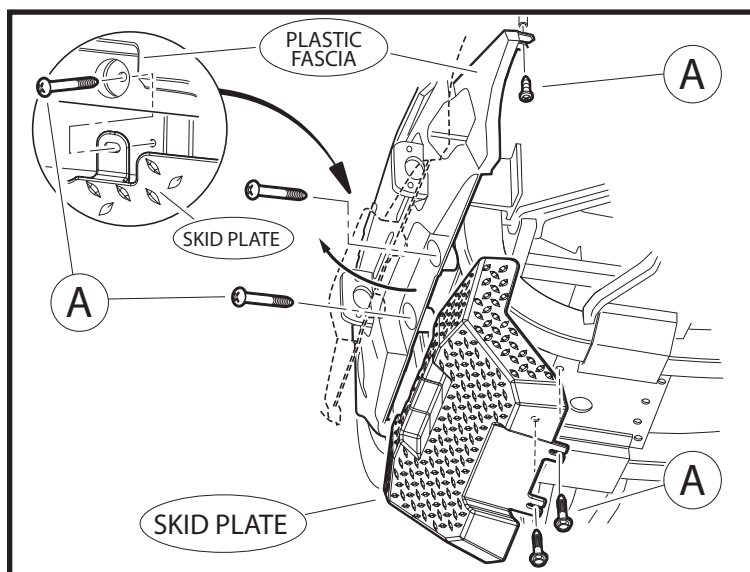

“Figure 2” Skid Plate Removal

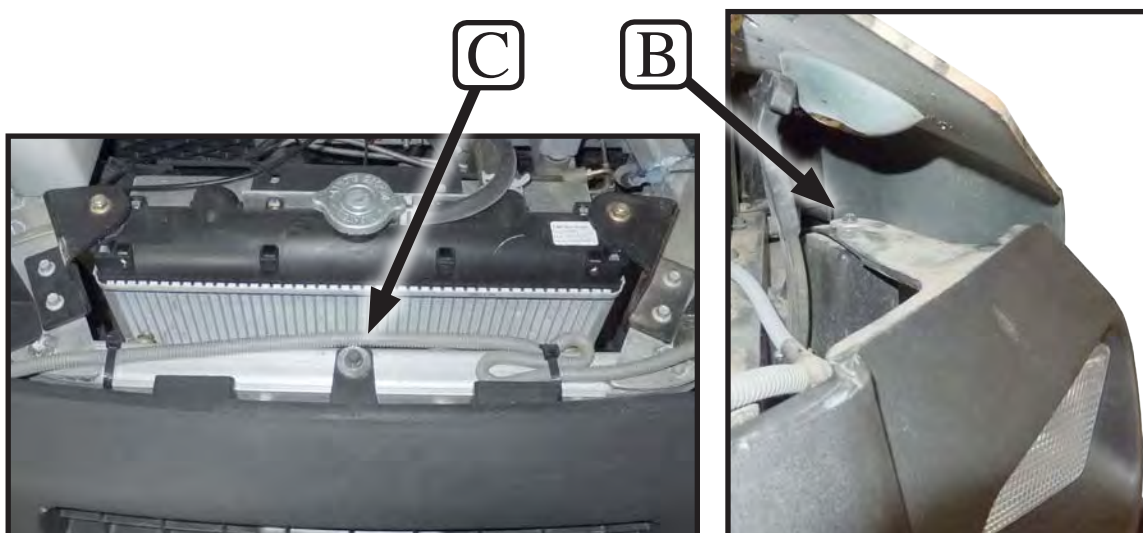

“Figure 3” Front Plastic Removal

3. Remove 2 lower frame bolts (D). See Figure 4.
4. Place mount plate up to frame and install upper portion of mount using 3/8" x 3" Bolts, Washers, and Flange Nuts (E) as shown in Figures 1&5. Install lower portion of mount using the M10 Flange Bolts (F), supplied in the hardware kit. See Figure 6.
5. Tighten down all bolts.
6. Reinstall front fascia using instructions from 1 and 2 in reverse.

*Note: Skid Plate will not be reinstalled.*

7. See UTV Plow Tube System instruction manual for tube attachment.

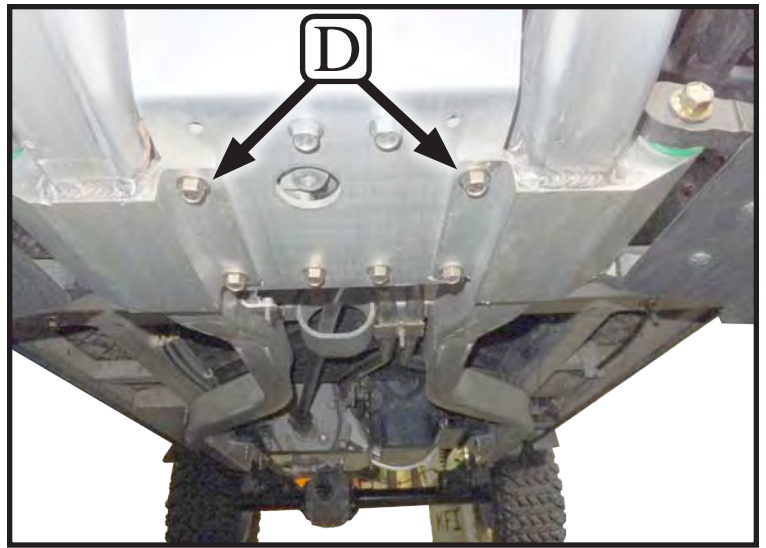

*"Figure 4" Lower Bolt Removal*

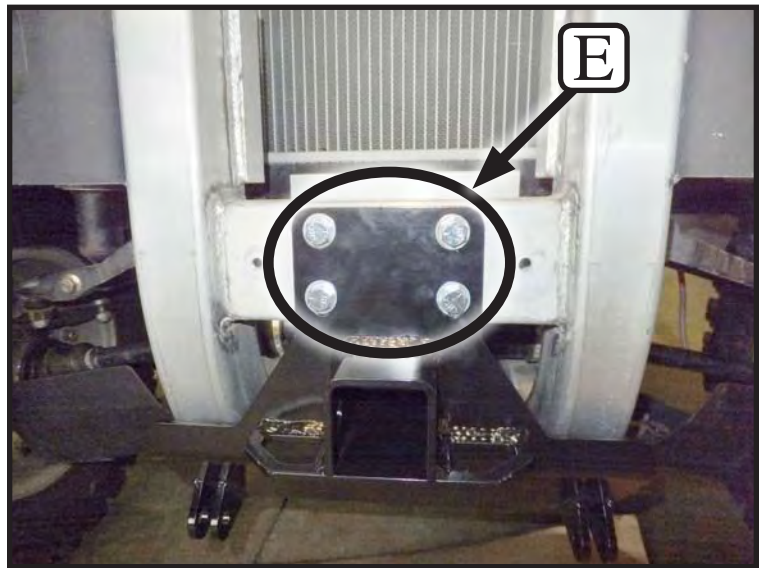

*"Figure 5" Mount Plate Install*

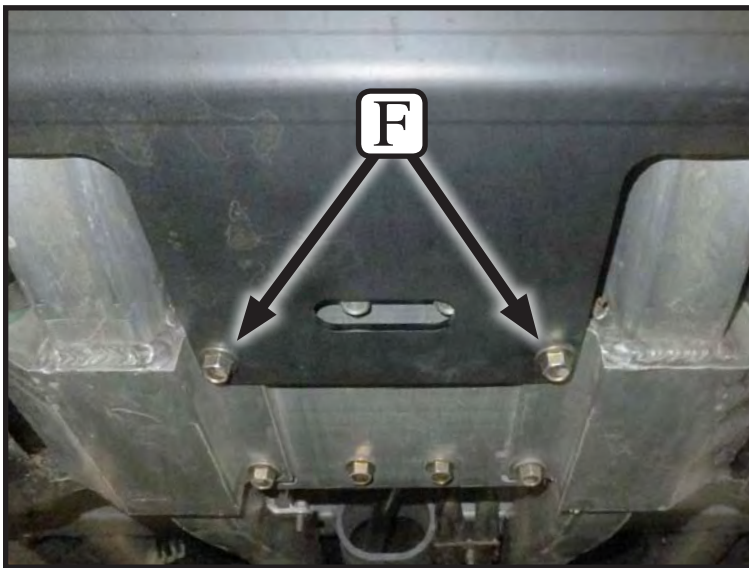

*"Figure 6" Mount Plate Install*

