

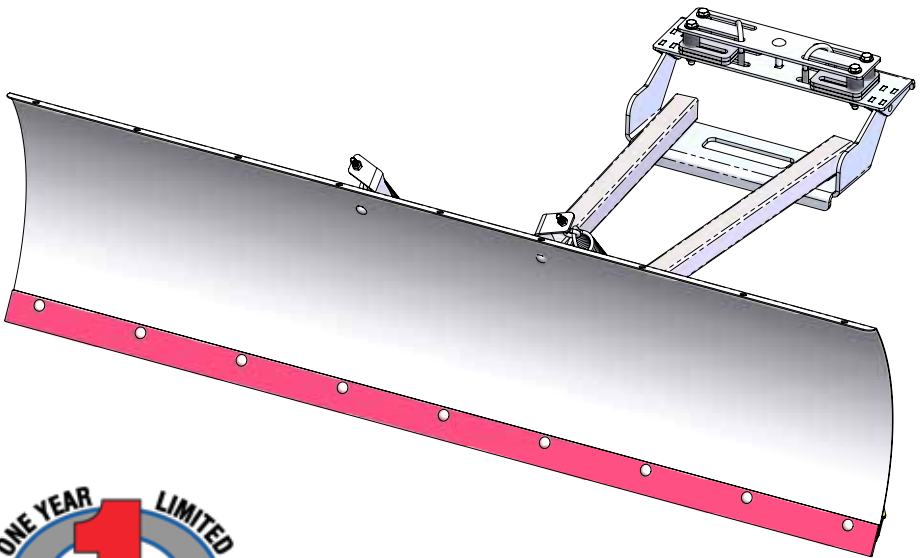

## Instruction Manual



# Safety Rules

## WARNING

- Read this manual thoroughly before operating your plow. Failure to follow instructions could result in serious injury or death.
- Do not exceed 5 mph, even with blade raised.
- Make sure that all nuts and bolts are tightened per installation instructions.
- Never operate this KFI product with missing or damaged parts.
- Drive slowly over bumpy and rough terrain, driving fast could cause damage to winch or plow.
- Never raise the plow above point of contact as it could cause damage to machine, plow or winch.
- Always perform regular inspections and maintenance on plow tubes and hardware before use.
- Operate with extreme caution on slopes, steep grades, and rough terrain.
- Be aware of any possible hidden objects under the snow.
- Do not ram the blade into the pile.

## CAUTION

- Take care when installing PLOW SPRINGS as they will be under tension.
- Use care when lifting components into place.

## DANGER

Never stand or ride on the plow.

## Manual Conventions

This manual uses the following symbols to help differentiate between different kinds of information. The safety symbol is used with a key word to alert you to potential hazards in operating and owning a plow.

Follow all safety messages to avoid or reduce the risk of serious injury or death.

## CAUTION

CAUTION indicates a potentially hazardous situation which, if not avoided, may result in minor or moderate injury.

## CAUTION

CAUTION used without the safety alert symbol indicates a potentially hazardous situation which, if not avoided, may result in property damage.

## DANGER

DANGER indicates an imminently hazardous situation which, if not avoided, will result in death or serious injury.

## NOTE

If you have questions regarding your plow, we can help. Please call our help line at 1-877-346-2050.

## WARNING

WARNING indicates a potentially hazardous situation which, if not avoided, could result in death or serious injury.

To help you make informed decisions regarding safety, we have included instructions and information on labels. This information is provided with the intent to help avoid potential hazards that may harm you or others. It is, in no way, possible for us to inform you of every hazard you may come across with this product.

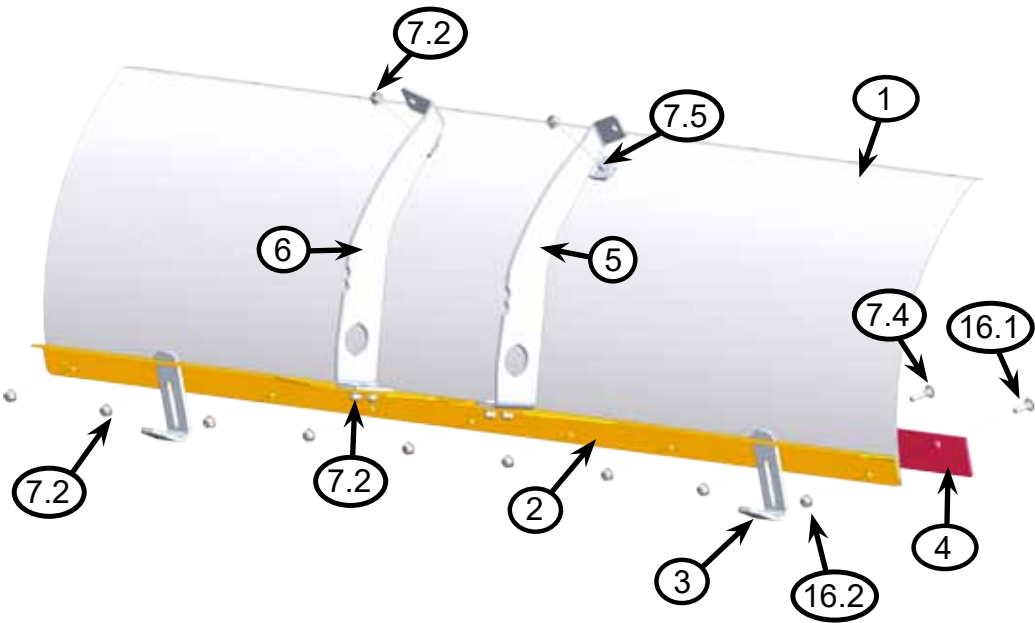

## 60" SNO-DEVIL BLADE Parts List

ITEM	PART#	DESCRIPTION	QTY.
1	105563	SNO-DEVIL BLADE	1
2	105561	SNO-DEVIL BLADE SUPPORT BRACKET	1
3	105158	SNO-DEVIL BLADE FOOT	2
4	105609	SNO-DEVIL BLADE WEAR BAR	1
5	105113	SNO-DEVIL BLADE GUSSET RH	1
6	105114	SNO-DEVIL BLADE GUSSET LH	1
7	HK-142	HARDWARE KIT	1
7.1	CB-5Z-031-18-075	5/16-18 x 3/4 CARRIAGE BOLT, STEEL, ZINC PLATED	4
7.2	HNFN-5Z-031-18	5/16-18 HEX FLANGE NYLOCK NUT, GR5, ZINC PLATED	13
7.3	CB-5Z-031-18-100	5/16-18 x 1.00 CARRIAGE BOLT, STEEL, ZINC PLATED	5
7.4	CB-5Z-031-18-125	5/16-18 x 1 1/4 CARRIAGE BOLT, STEEL, ZINC PLATED	2
7.5	CBSN-5Z-031-18-075	5/16-18 x 3/4 SHORT NECK CARRIAGE BOLT, STEEL, ZINC PLATED	2
16	HK-165	HARDWARE KIT	1
16.1	CB-5Z-031-18-100	5/16"-18 X 1.00" CARRIAGE BOLT	4
16.2	HNFN-ZP-0313-18	5/16"-18 FLANGED NUT NYLOCK	4



# Plow Blade Installation Instructions

1.  Before starting the assembly of the blade and tubes see your Hybrid Mount (105515) instructions to ensure it will work with your ATV.

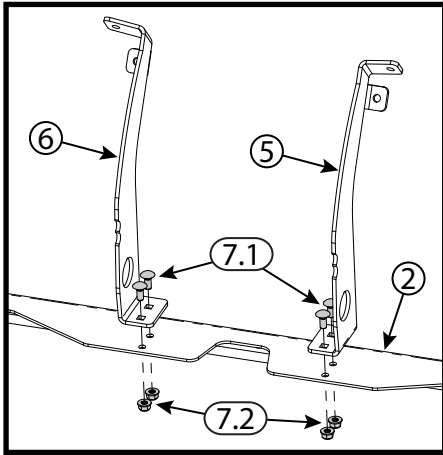

“Figure 1” Blade Frame Assembly

## (Install all hardware loose)

2. Install the left (6) and right (5) blade gussets to the support bracket (2) using the 5/16” x 3/4” standard carriage bolts (7.1) and nuts (7.2). This will create the blade frame assembly.

*Note: there are 2 different neck lengths on a carriage bolt, short and standard. See Figure 3 for differences.*

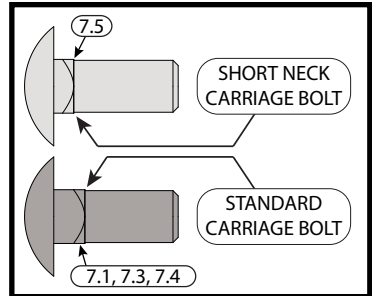

“Figure 3” Carriage Bolt Diagram

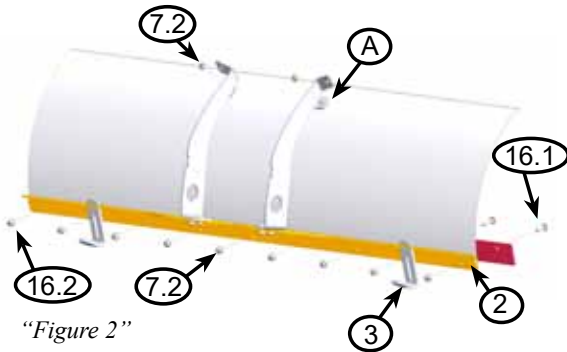

“Figure 2”

3. Attach the blade frame assembly to the blade in location (A) using 5/16” x 3/4” Short Neck carriage bolts (7.5) and nuts (7.2). See Figure 2.

4. Next attach the wear bar (4) to the plow blade (1) by installing the **seven** 5/16” x 1” standard carriage bolts (7.3 and 16.1) in the center and ends through the cutter blade (4), plow blade (1) and support bracket (2). Secure the carriage bolts with 5/16” nuts (7.2 and 16.2). See Figure 3.

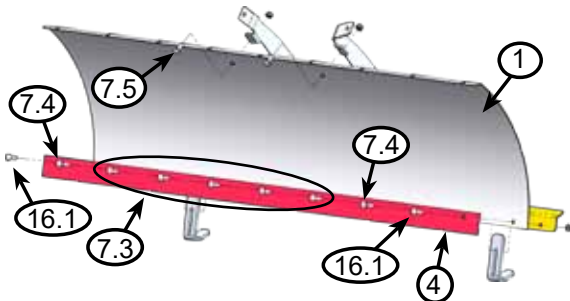

“Figure 3”

5. Install the blade feet (3) as shown in Figure 3 using the 5/16” x 1 1/4” standard carriage bolts (7.4).

*Note: Adjust the feet by loosening the nuts and sliding the feet up and down to the desired position. Start with feet in minimum height position and adjust for surface.*

6. Tighten down all bolts.

# Push Tube Assembly and Installation Instructions

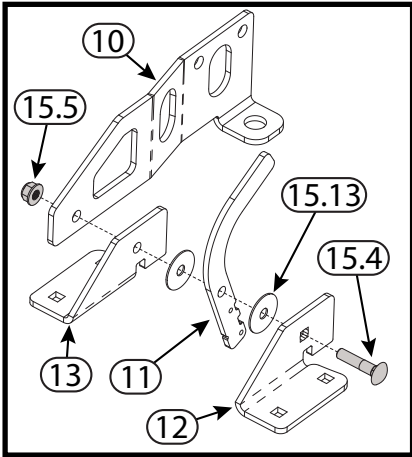

“Figure 4” Angle Lever Assembly (B)

7. Assemble Left Handle Plate (13), 2X Washer (15.13), Pivot Handle (11), Right Handle Plate (12), and Hook Plate (10) using the 5/16" x 1 1/2" standard carriage bolt (15.4) and 5/16" flange nut (15.5) as shown in Figure 4. **Tighten down nut so that Angle lever moves freely.** This will create the angle lever assembly. (B)

8. Install Angle Lever Assembly (B) to the Tube Weldment (8) as shown in Figure 5. Use the 5/16" x 1" standard carriage bolts (15.8) and 5/16" nuts (15.5) to secure the left and right Handle Plates. Tighten down bolts.

9. Secure the Pivot Plate (9) to the Tube Weldment (8) and Hook Plate (10) using the 5/8" x 1 3/4" structural bolt (15.10), 5/8" lock washer (15.14) and 5/8" lock nut (15.2) as shown in Figure 5. **Tighten down nut and bolt so that the plate will pivot with ease but is not loose.**

10. Install the Pivot Lever Spring (16) to the tab on the Tube Weldment (C) and the hole in the Pivot Handle (11) as shown in Figure 6.

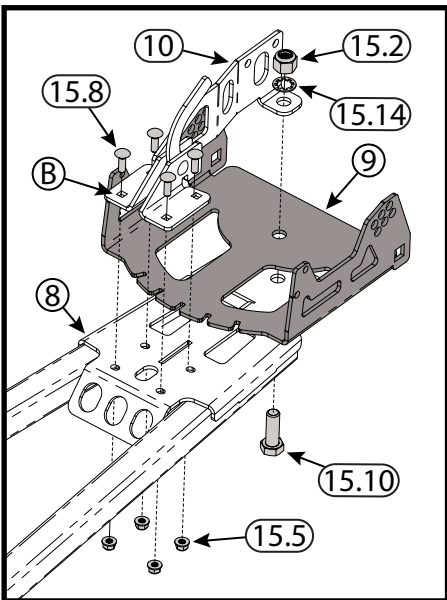

“Figure 5” Angle Plate and Angle Lever Assembly Install

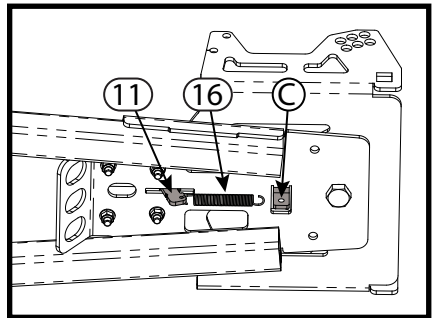

“Figure 6” Pivot Lever Spring Install

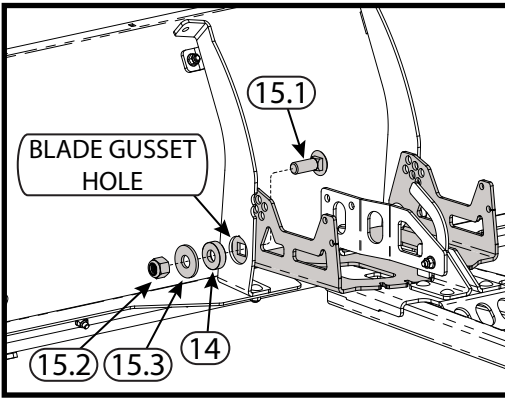

“Figure 7” Pivot Bolt Assembly

11. Place pitch bushing (14) into hole in blade gusset and secure blade to tube system by fastening with the 1<sup>3/4</sup>” carriage bolt (15.1), washer (15.3) and lock nut (15.2), as shown in Figure 7. Repeat on right hand side.

12. Hook the plow springs (Item 18) into the smaller rear holes in the pivot plate (9), as shown in Figure 8. Place the eyebolts (Item 15.11) onto the end of the plow springs and secure the eyebolts onto the plow blade gusset using nut (Item 15.12) and washer (Item 15.9), as shown in Figure 8. Leave spring tension loose as you will decide tension in Step 15.

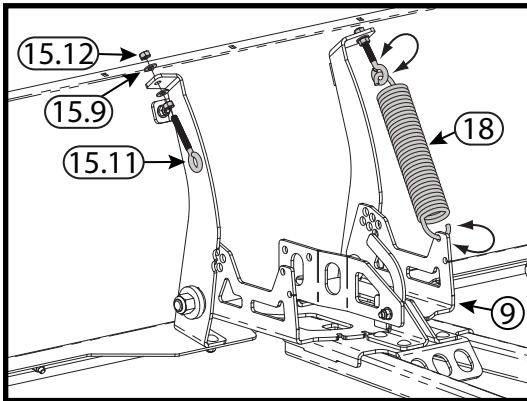

“Figure 8” Spring Assembly

13. Decide desired pitch of blade. Each hole allows 5 degrees of blade pitch adjustment.

**Note:** Figure 9 shows the default position.

14. With springs installed pitch blade under tension and install 3/4” hex socket head cap screw (15.7) using 3/8” Allen wrench or pliers; and 7/16” lock nut (15.6) into desired pitch position hole. As shown in Figure 9.

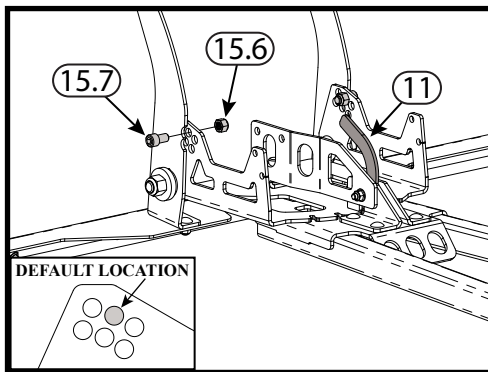

“Figure 9” Pitch Adjustment Bolt  
(Spring not shown for clarity.)

15. Tighten nuts down on eye bolt until desired spring tension is reached. See Figure 10 for default tension.

**Note:** For each 1/4” that the nut is tightened it will add 7 lbs of spring tension. This will make a total of 14 lbs with both springs.

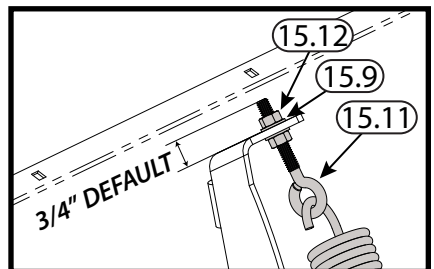

“Figure 10” Spring Adjustment

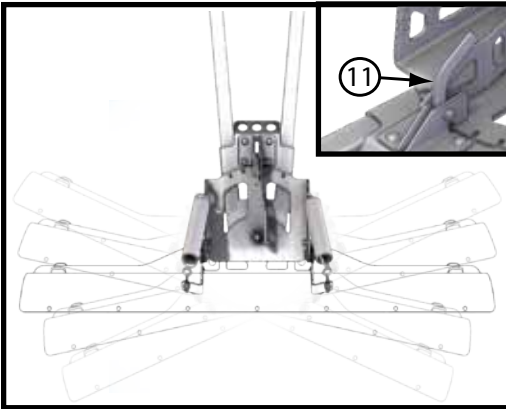

“Figure 11” Blade Rotation Angle

16. The tube system has five positions of rotation for your blade. Each adjustment is a 12.5 degree increment. To adjust, push down on the handle (Figure 11, Item 11) and rotate your blade left or right until you reach the desired angle.

*Note: Make sure handle is locked in before plowing.*

17. Attach the tube system to the Hybrid Mount System, by first positioning the tube system, with blade installed, under your ATV. Then raise tube attach points to the mount and line up the holes on mount plate with the holes in the tube system. Insert Pin through holes and secure on other side with clips as shown in Figure 12.



“Figure 12” Tube System Attachment

18. Attach winch hook to one of 2 locations. See Figure 13. Figure 14 shows the best winch line angle, use this to determine which attachment point to use.

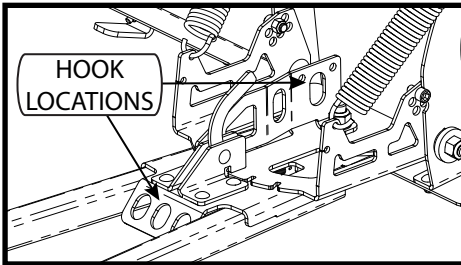

“Figure 13” Hook Attachment Points

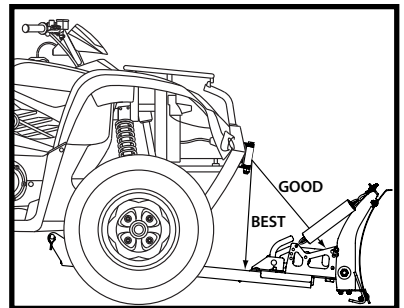

“Figure 14” Winch Line Angle





# 1 Year Limited Warranty

Kappers Fabricating, Inc. (KFI) warrants to the original purchaser that the product is free from defects in materials and workmanship for a period of one (1) year from the original date of purchase. We will repair or replace, at our discretion, parts found to be defective due to materials or workmanship. This warranty is subject to the following limitations and exclusions:

**Commercial Use:** The warranty period for any product used for commercial or rental is limited to ninety (90) days from the date of original purchase.

**Limitations:** This warranty applies only to products which have been properly assembled, adjusted, and operated in accordance with the instructions contained within this manual. This warranty does not apply to any product of Kappers Fabricating, Inc. that has been subject to alteration, misuse, abuse, improper assembly or installation, or shipping damage.

**Exclusions:** Excluded from this warranty are normal wear, normal adjustments, and normal maintenance.

THIS WARRANTY DOES NOT APPLY TO ANY INCIDENTAL OR CONSEQUENTIAL DAMAGES AND ANY IMPLIED WARRANTIES ARE LIMITED TO THE SAME TIME PERIODS STATED HEREIN FOR ALL EXPRESSED WARRANTIES.

THE WARRANTY SET FORTH ABOVE IS THE ONLY WARRANTY. THERE ARE NO OTHER WARRANTIES, EXPRESS OR IMPLIED, INCLUDING BUT NOT LIMITED TO IMPLIED WARRANTIES OF MERCHANTABILITY OR FITNESS FOR A PARTICULAR PURPOSE.

Some states do not allow the exclusion of implied warranties or the exclusion or limitation of liability for incidental or consequential damages, or limitations on how long an implied warranty lasts, so the above limitation or exclusion may not apply to you. This warranty gives you specific legal rights. You may also have other rights that vary from state to state.

In the event you have a claim under this warranty, contact KFI's Technical Service and KFI will troubleshoot any issue via phone or e-mail. If the problem is not corrected by this method, KFI will, at its option, authorize evaluation, repair or replacement of the defective part or component at a KFI Service Center. KFI will provide you with a case number for warranty service. Please keep it for future reference. Repairs or replacements without prior authorization, or at an unauthorized repair facility, will not be covered by this warranty.

All transportation charges, damage, or loss incurred during transportation of parts submitted for replacement or repair under this warranty shall be borne by the purchaser. Should you have any questions concerning this warranty, please contact us toll-free at 1-877-346-2050. The model number, serial number (If applicable), date of purchase, and the name of the authorized KFI dealer from whom you purchased the product will be needed before any warranty claim can be processed.

For warranty inquiries outside the U.S.A. and Canada, contact your local dealer/distributor.

For countries not covered by a local dealer/distributor, please contact us at [www.kfiproducs.com](http://www.kfiproducs.com).



**1-877-346-2050**

KFI Products  
721 Sata Dr.  
Spring Valley, MN 55975  
[www.kfiproductions.com](http://www.kfiproductions.com)

Made in the USA

Corporate Office:  
Kappers Fabricating, Inc.  
P.O. Box 32  
1015 Industrial Drive  
Spring Valley, MN 55975

# Product Registration

---

Please register your product with Kappers Fabricating, Inc. (KFI) within fifteen (15) days of purchase to assist us in handling any warranty issues that may arise by filling out this Registration card and submitting it with a copy of your sales receipt from one of KFI's official resellers. Failure to complete and return this Registration card does not diminish your warranty rights. Please refer to the above section for complete terms of this warranty.

## **WARRANTY IS NON-TRANSFERABLE**

Please Print Clearly

Model # \_\_\_\_\_

Name \_\_\_\_\_

Street Address \_\_\_\_\_

City \_\_\_\_\_ State \_\_\_\_\_ Zip Code \_\_\_\_\_

Phone \_\_\_\_\_ Fax \_\_\_\_\_ Email \_\_\_\_\_

Date of Purchase \_\_\_\_\_ Authorized KFI Dealer Name \_\_\_\_\_

Fill out and send this section to:  
KFI Products

Warranty Registration Department  
721 Sata Drive, PO Box 32  
Spring Valley, MN 55975, U.S.A.



**1-877-346-2050**

KFI Products  
721 Sata Dr.  
Spring Valley, MN 55975  
[www.kfiproductions.com](http://www.kfiproductions.com)

Made in the USA

Corporate Office:  
Kappers Fabricating, Inc.  
P.O. Box 32  
1015 Industrial Drive  
Spring Valley, MN 55975