

# YAMAHA RMAX

Plow Mount PART #106190

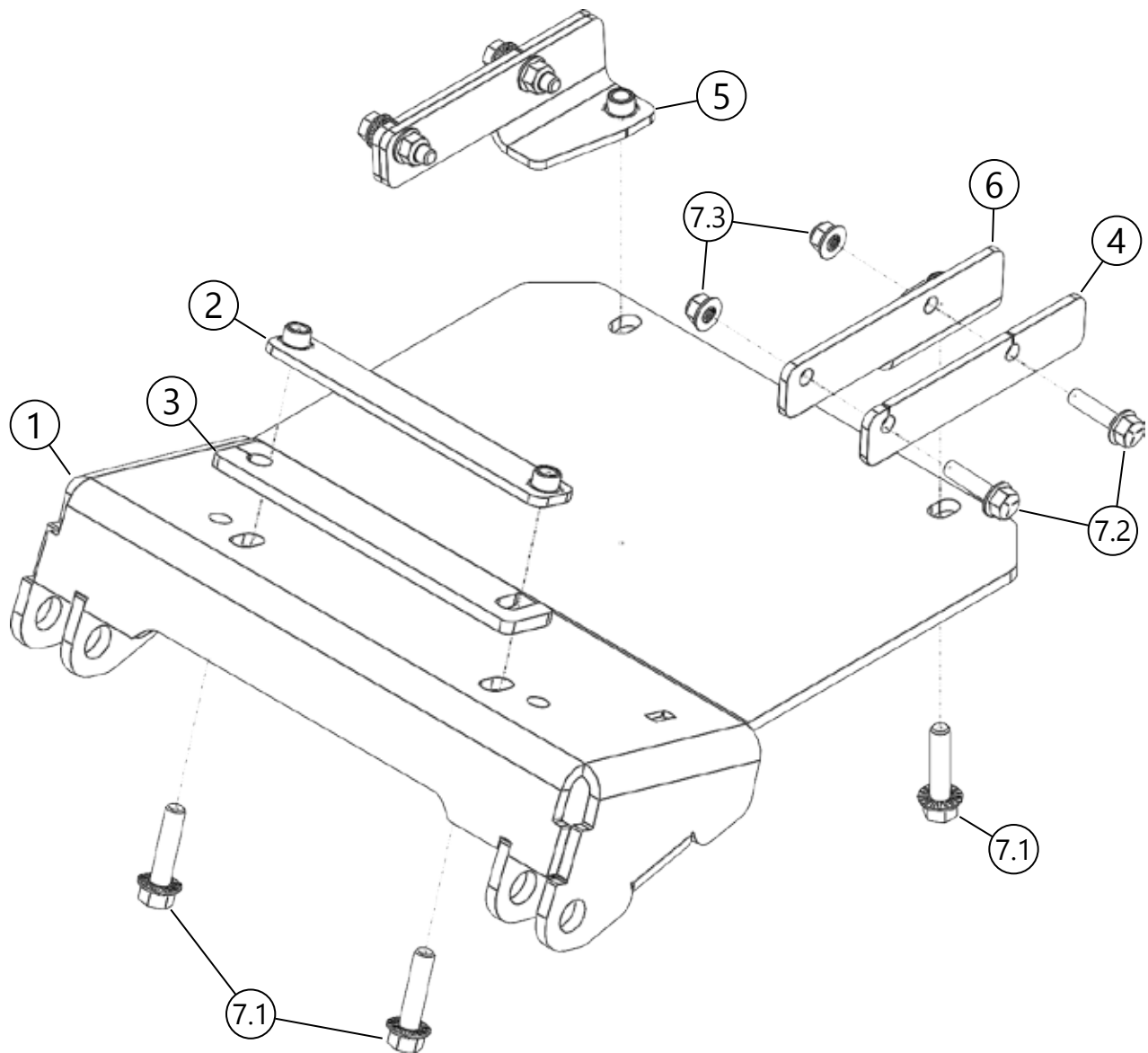

Item #	Qty.	Description
1	1	Plow Mount
2	1	Nut Plate
3	1	Front Frame Spacer
4	1	Rear Frame Spacer
5	2	Mount Bracket (passenger side)

Item #	Qty.	Description
6	1	Mount Bracket (driver side)
7	1	Hardware Kit (HK-389)
7.1	4	3/8"-16 x 1.50 Hex Flange Bolt
7.2	4	5/16"-18 x 1.25 Hex Flange Bolt
7.3	4	5/16"-18 Hex Flange Nylock Nut



# INSTALLATION INSTRUCTIONS

**Note:** Make sure all hardware needed to complete this mount is in the package. Thoroughly read through and understand the instructions before installing.

1. Remove the front portion of the skid plate on the machine by removing bolts (A & B) as shown in **Figure 1**. Set bolts aside as they will be reused.
2. Set plow mount (1) onto skid plate and insert bolts (7.1) into holes (B) positioning plow mount onto skid plate in the proper location as shown in **Figure 2**.
3. Measure 1 5/16" from bottom of plow mount (1) to the lower feature of the skid plate as shown in **Figure 2**.
4. Mark skid plate at holes (C) with a marker using plow mount (1) as a template as shown in **Figure 2**, remove plow mount (1) from skid plate and drill through the skid plate on the center of each of the four marks using a 1/2" drill bit. **NOTE:** Drilling a larger hole or slotting the hole may be needed for more adjustment in plow mount (1).
5. Set mount brackets (5&6) along with rear frame spacers (4) inside of frame and loosely secure to holes (D) in frame using bolts (7.2) and nuts (7.3) as shown in **Figures 3 & 4**. **NOTE:** Bolts will go through larger outside frame holes.
6. Set nut plate (2) in frame lining up holes in nut plate (2) with holes (E) in the frame as shown in **Figures 3 & 4**.

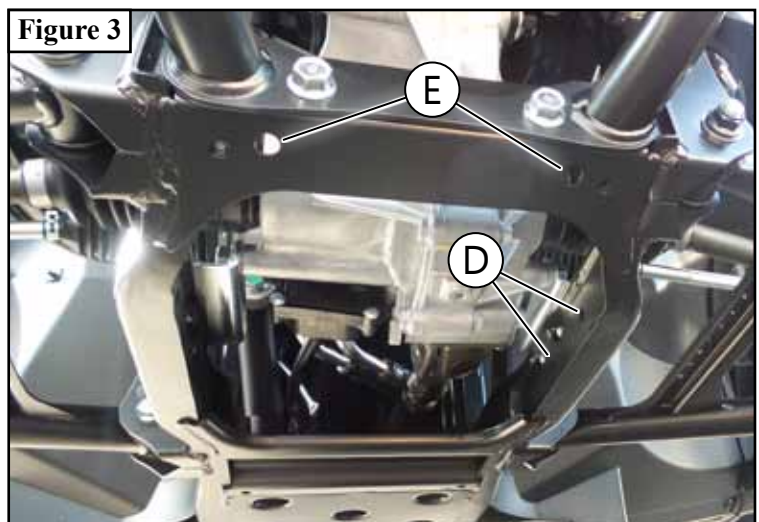
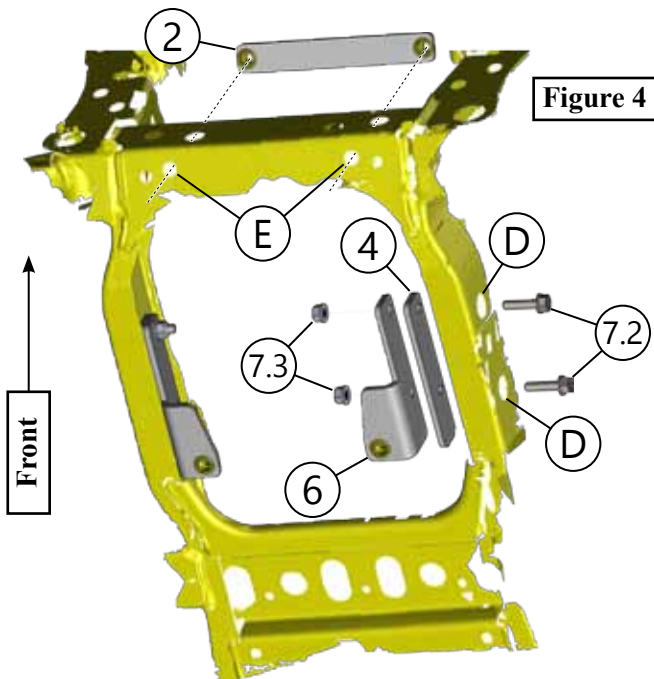
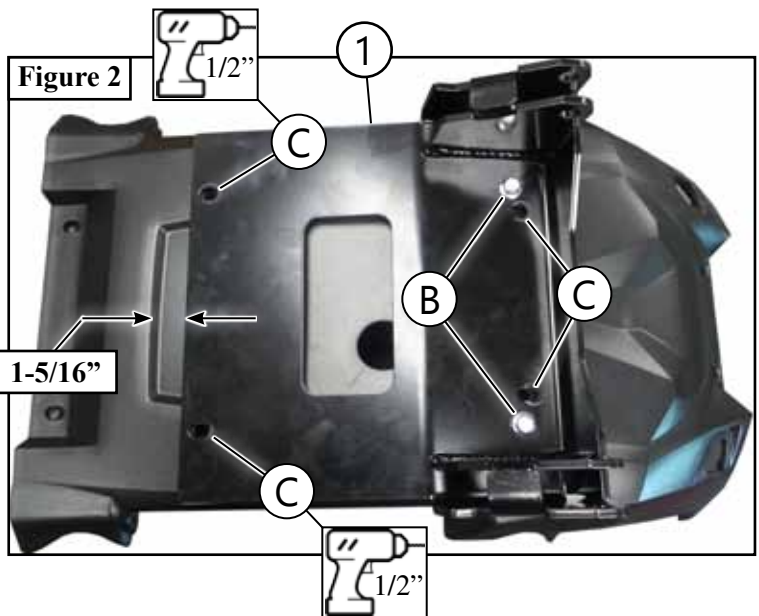
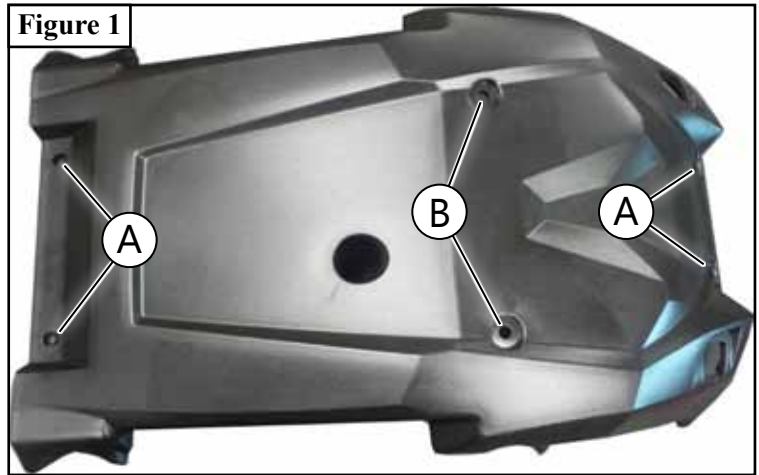

# INSTALLATION INSTRUCTIONS

7. Re-install skid plate using OEM bolts removed in step 1.
8. Set plow mount (1) in place and loosely secure rear of plow mount (1) to mount brackets (5 & 6) using bolts (7.1) as shown in **Figure 5**.
9. Place spacer (3) between plow mount (1) and skid plate holes (C) and secure front of plow mount (1) using bolts (7.1) as shown in **Figure 5**. **NOTE:** *Place the closed hole end of the spacer behind the plow mount (1) first. After loosely securing plow mount with bolts (7.1), swing open end of spacer down between plow mount (1) and skid plate.*
10. Tighten all hardware evenly.
11. **NOTE:** *Plow mount (1) can be removed in the off season so it does not reduce the ground clearance of the machine. If you do not wish to re-insert hardware back into nut plate (2) and mount bracket (5 & 6), keep hardware with plow mount to be reused.*

