

HYDRAULIC PLOW ACTUATOR BRACKETS

PLOW ACCESSORY

Mount: PART # 106230
Hardware Kit: HK-178

Kit Components:

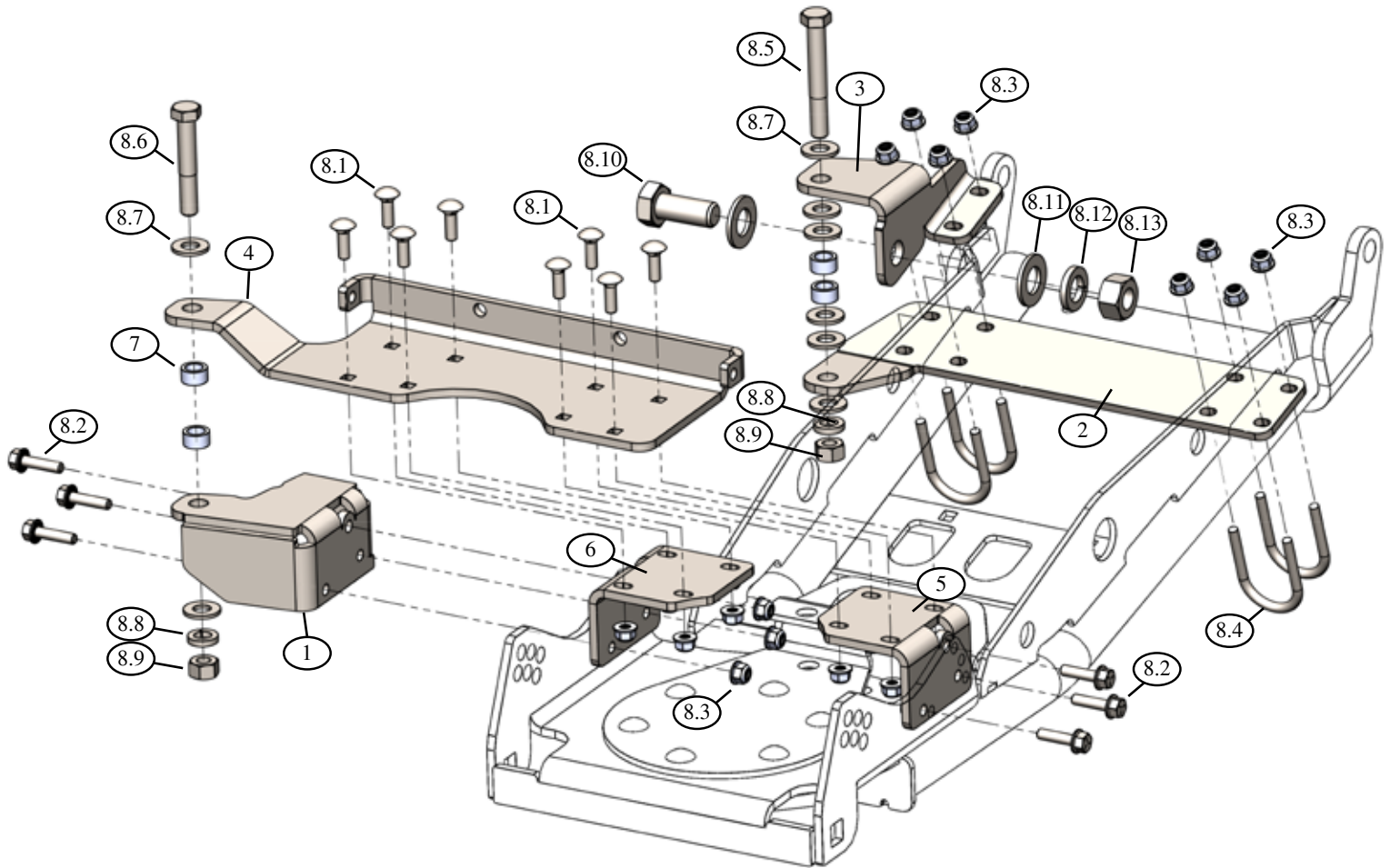

Item #	Qty.	Part #	Description
1	1	105802	FRONT OUTER BRKT
2	1	105803	REAR LOWER BRKT
3	1	105804	REAR UPPER BRKT
4	1	105989	FRONT SUPPORT BRKT
5	1	105992	INNER BRKT DRIVERS SIDE
6	1	105991	INNER BRKT PASSENGER SIDE
7	4	105231	BUSHING - .532 ID X .750 OD X .400
8	1	HK-178	HARDWARE KIT
8.1	8		5/16-18 X 1" CARRIAGE BOLT
8.2	6		5/16-18 X 1-1/4" HEX FLANGE BOLT
8.3	22		5/16-18 HEX FLANGE NYLOK NUT
8.4	4		5/16-18 X 1-1/2 X 2-1/2 X 1-1/4 THREAD U-BOLT

Item #	Qty.	Part #	Description
8.5	1		1/2-13 X 3-1/2" HEX BOLT
8.6	1		1/2-13 X 3" HEX BOLT
8.7	10		1/2 SAE FLAT WASHER
8.8	2		1/2 LOCK WASHER
8.9	2		1/2-13 HEX NUT
8.10	1		M18 X 2.5 X45MM HEX BOLT
8.11	2		3/4 SAE WASHER
8.12	1		3/4 LOCK WASHER
8.13	1		M18 X 2.5 HEX NUT

INSTALLATION INSTRUCTIONS:

Note: Make sure all of the hardware needed to complete this mount is in the package. Read through and understand the instructions before installing.

1. Remove handle for lift latch assembly. Lift the handle up compressing the spring. Remove the C-Clip under the washer. Remove the handle, spring and washer as shown in Figure 2.

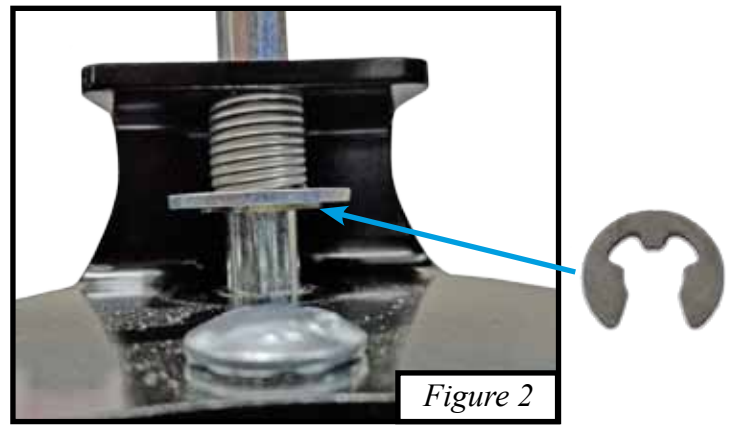

2. Slide the Rear Lower Bracket (2) through the gaps of the push tube as shown in Figure 3.

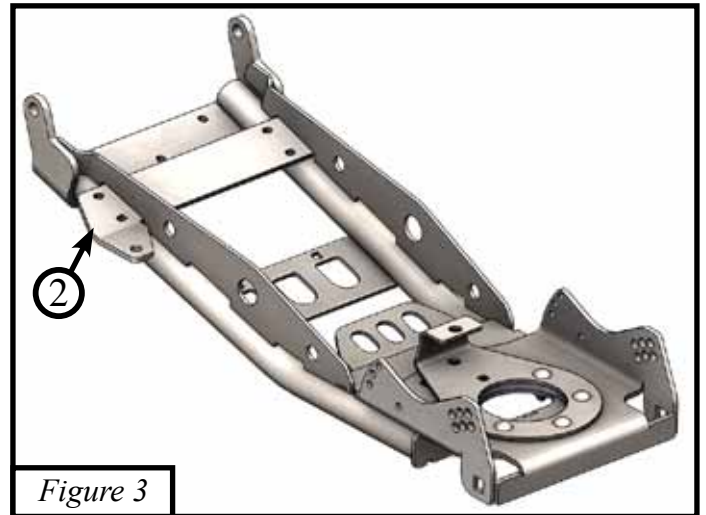

3. Set the Rear Upper Bracket (3) on top of the lower bracket (2) on the passenger side of the tube. Line up the holes on the brackets and tube. Shown in Figure 4.

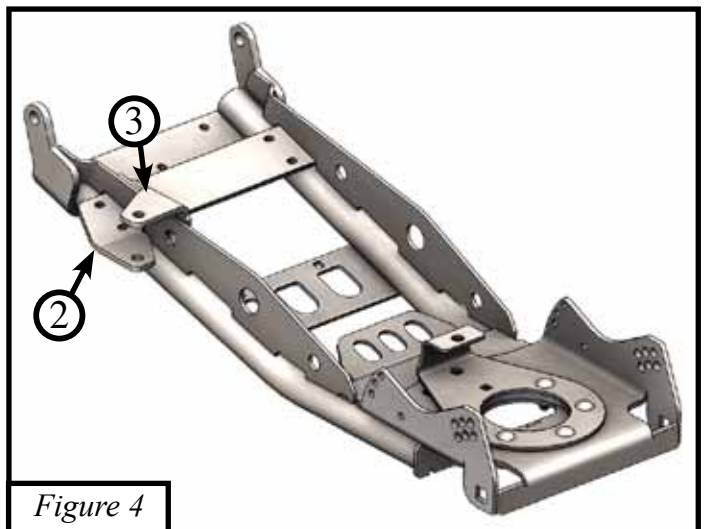

4. Insert the four U-bolts (8.4) through the rear brackets (2 & 3) shown in Figure 5. Loosely attach the 5/16" nuts (8.3) to the U-bolts.

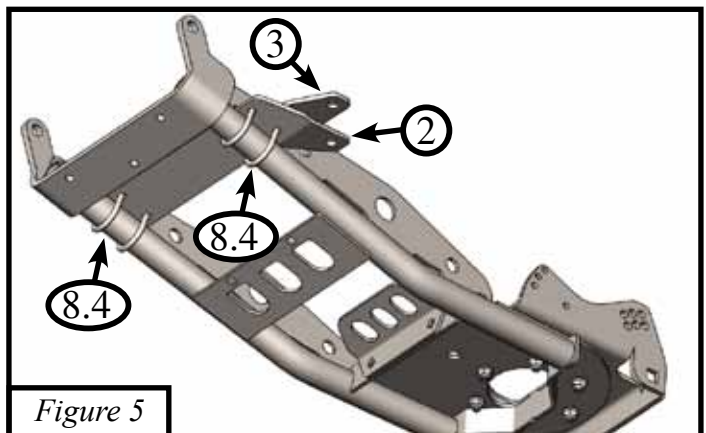

5. Place bolt (8.10) through flat washer (8.11) and Rear Lower Bracket. Slide washer (8.11) lock washer (8.12) and nut (8.13) onto the bolt (8.10) shown in *Figure 6*. Tighten bolt down snug.

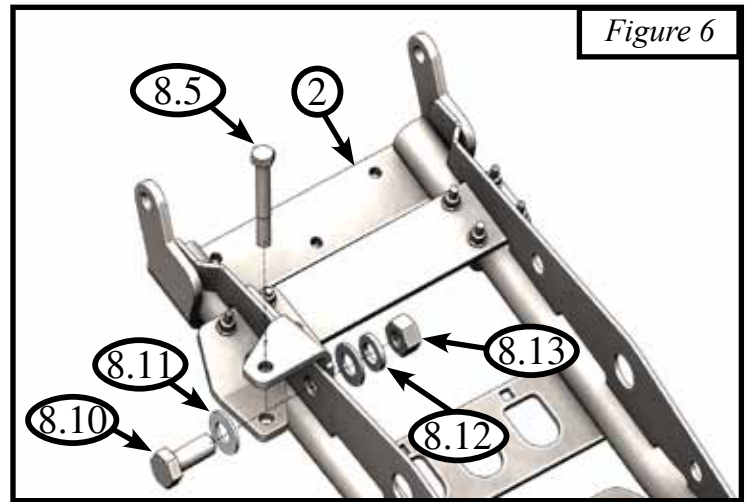

6. Loosely place bolt (8.5) into position and align vertical/ perpendicular through the two holes. Tighten all U-bolt nuts down evenly as shown in *Figure 6*.

7. Line up Inner Bracket Drivers Side (5) with holes in rear of cradle and place three bolts (8.2) as shown in *Figure 7* and tighten down all hardware evenly.

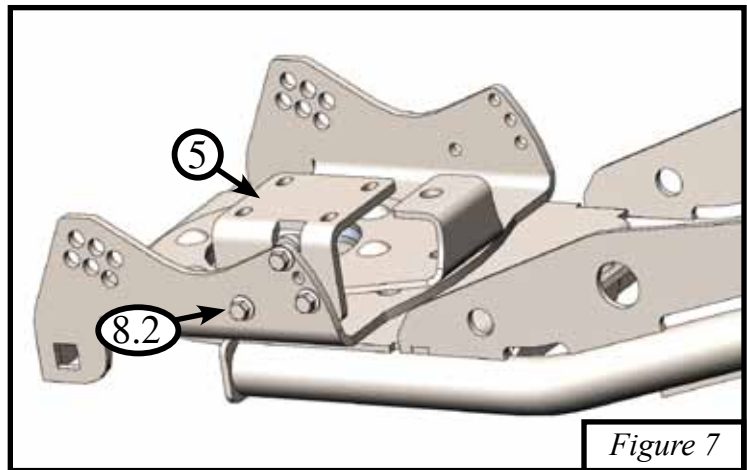

8. Line up Front Outer Bracket (1) and Inner Bracket Passenger Side (6) with holes in rear of cradle shown in *Figure 8*. Place three bolts (8.2) and Nuts (8.3) loosely as shown in *Figure 8*.

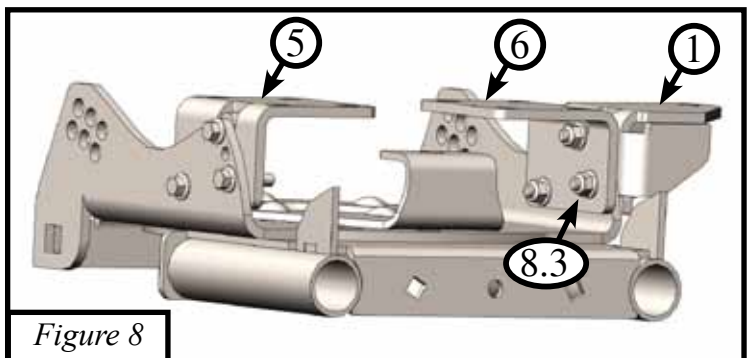

9. Place front support bracket (4) on top of brackets (5) and (6) as shown in *Figure 9*. Using eight carriage bolts (8.1) to secure the support bracket down leaving hardware loose.

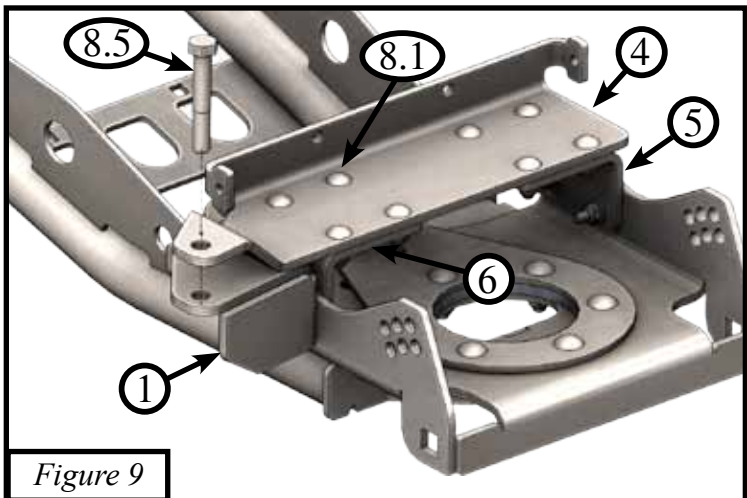

10. Loosely place bolt (8.5) into position and align vertical/ perpendicular through the two holes. Tighten all carriage bolt nuts down evenly as shown in *Figure 9*.

11. Place bolt (8.5) through flat washers (8.7), bushings, Hydraulic Actuator (105965 NOT INCLUDED), and rear brackets. Slide washer (8.7) lock washer (8.8) and nut (8.9) onto the bolt (8.5) shown in *Figure 10*. Tighten bolt down snug.

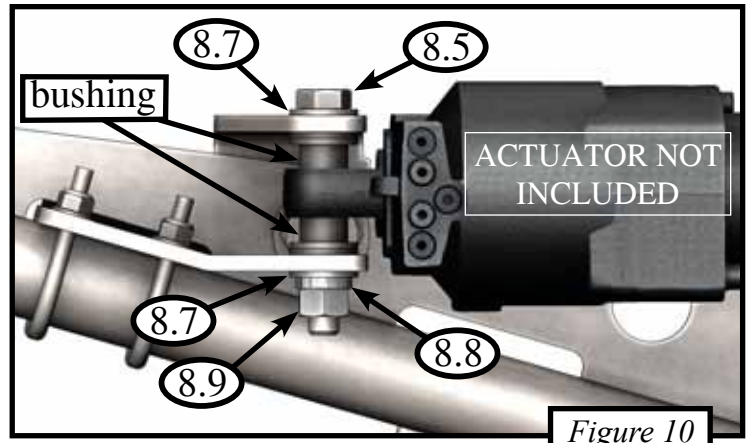

Figure 10

12. Place bolt (8.6) through flat washers (8.7), bushings, Hydraulic Actuator (105965 NOT INCLUDED), and front brackets. Slide washer (8.7), lock washer (8.8), and nut (8.9) onto the bolt (8.6) shown in *Figure 11*. Tighten bolt down snug.

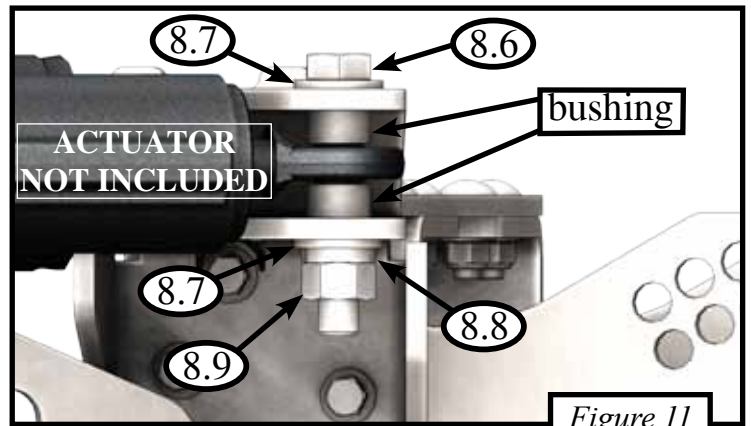

Figure 11

13. Periodically apply lubricant to the rear and front bushings on Hydraulic Actuator (105965 NOT INCLUDED). Also on front pivot of pushtube shown in *Figure 12*.

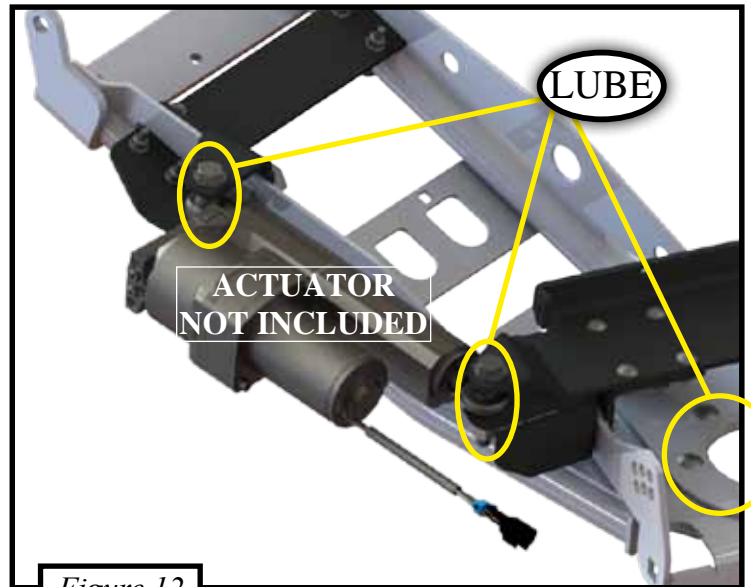

Figure 12

14. When all the brackets are installed you will have to move the spring mounting location. We have added a bend on the top with a hole on each side for your spring to connect to. Shown in *Figure 13*.

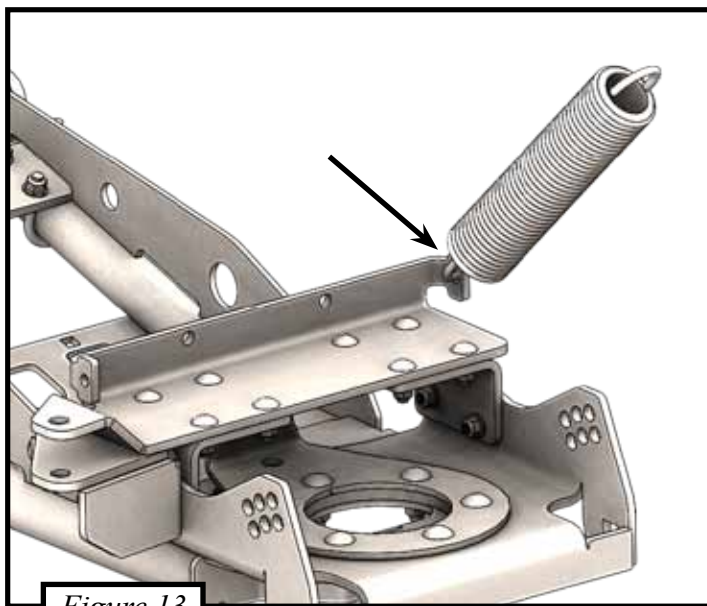

Figure 13

