

POLARIS RZR PRO XP PLOW MOUNT

Plow Mount PART #106235

Kit Components:		
Item #	Qty.	Description
1	1	A-Arm Mount
2	1	Plow Mount
3	1	HK-369
3.1	4	3/8" - 16 x 1.00 Hex Flange Bolt
3.2	2	3/8" - 16 x .75 Hex Flange Bolt
3.3	4	3/8" - 16 Hex Flange Nylock Nut
3.4	2	M12 - 1.75 x 80 Hex Flange Bolt
3.5	2	M12 - 1.75 Hex Flange Nylock Nut

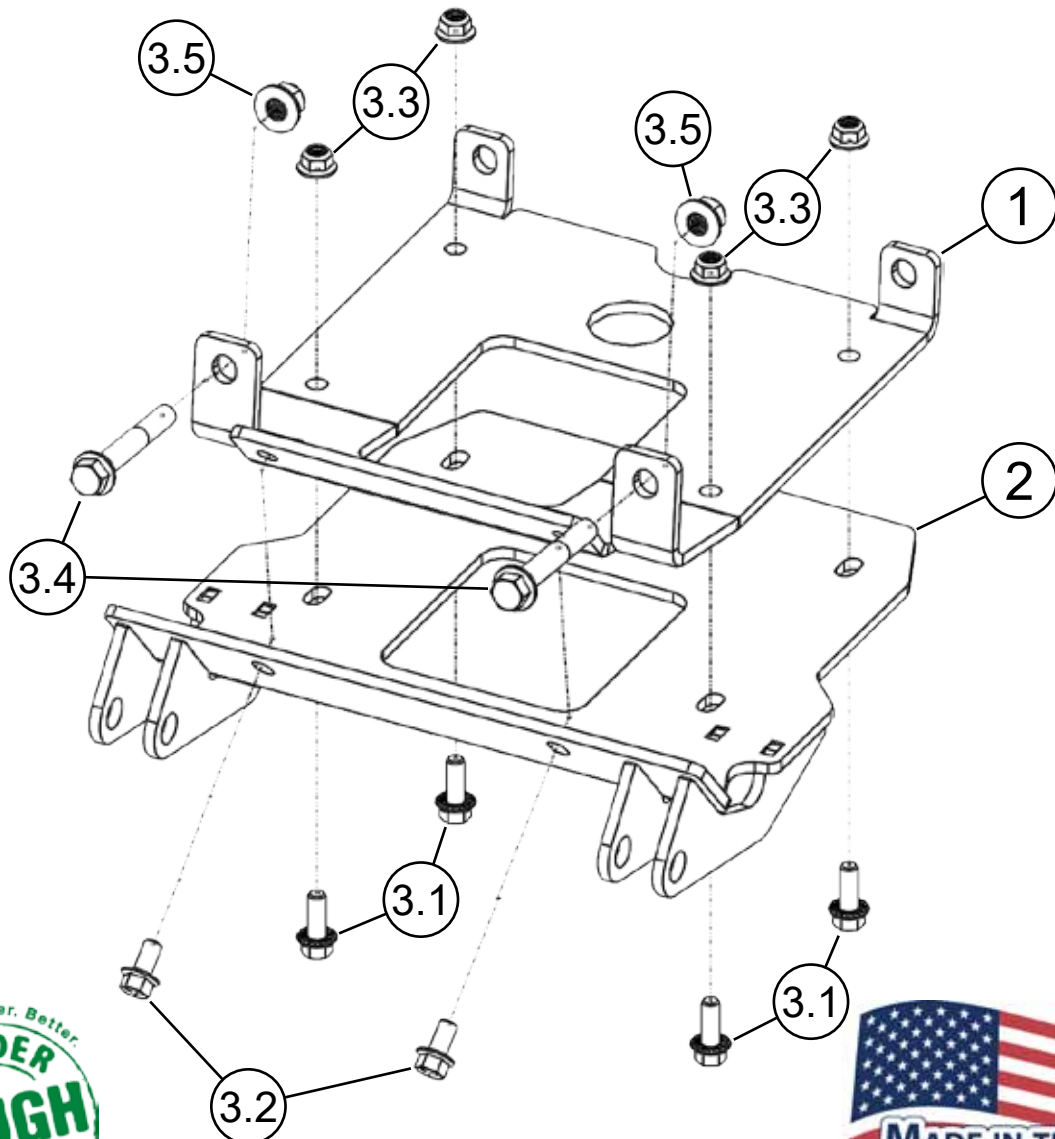

INSTALLATION INSTRUCTIONS

Note: Make sure all hardware needed to complete this mount is in the package. Thoroughly read through and understand the instructions before installing.

1. Remove the front fascia of the machine by removing bolts (A) as shown in **Figure 1** and set aside as it will be re-installed in a later step. **Note:** Passenger side shown, bolts on the driver side will be in the same location on the driver side of the front fascia.
2. Lift the front of the machine up removing all pressure off of the front a-arms. **Note:** Be sure to not obstruct the location in which the A-Arm Mount (1) will be placed when lifting the front of the machine up.
3. As shown in **Figure 2**, remove bolts (B) and discard as they will not be reused. Remove bolts (C) and set aside as they will be reused in a later step.
4. Set A-Arm Mount (1) in place and loosely fasten using OEM bolts (C) in the rear most location of the front a-arms and M12 bolts (3.4) and nuts (3.5) as shown in **Figure 3**. **Note:** Torque per your vehicle specification.
5. Set Plow Mount (2) over A-Arm Mount (1) and loosely secure the front of the mount using the two shorter 3/8" bolts (3.2). Secure the rear of Plow Mount (2) using the longer 3/8" bolts (3.1) and nuts (3.3) as shown in **Figure 4**.
6. Reinstall front fascia removed in step one and tighten all hardware evenly.

