

RETAIL WINCH DISPLAY

Display PART # 110465
 Hardware Kit: HK-073

Kit Components:

Qty.	Part Description
1.....	Winch Display Plate
1.....	Binder Display Bracket
2.....	Zip Tie
4.....	Spacer
4.....	M8-1.25 x 45mm Bolt
2.....	1/4"-20 x 1/2" Slotted Screw
2.....	1/4" Nylock Nut

INSTALLATION INSTRUCTIONS:

1. Assemble the roller fairlead to the fairlead bracket using the items included in your winch box. (See Figures 1&4)
2. Assemble winch to display using the supplied longer M8 bolts and spacers, see Figure 2, use washers and lock washers supplied with winch if needed.
3. Install mini-rocker switch using hardware provided with your winch. (See Figure 2) When installing the mini-rocker place the other half of the handle bar bracket to the back side.
4. Install binder display bracket using the 1/4" screws and nuts provided in the kit. (See Figure 3)



“Figure 1”



“Figure 2” Winch Install

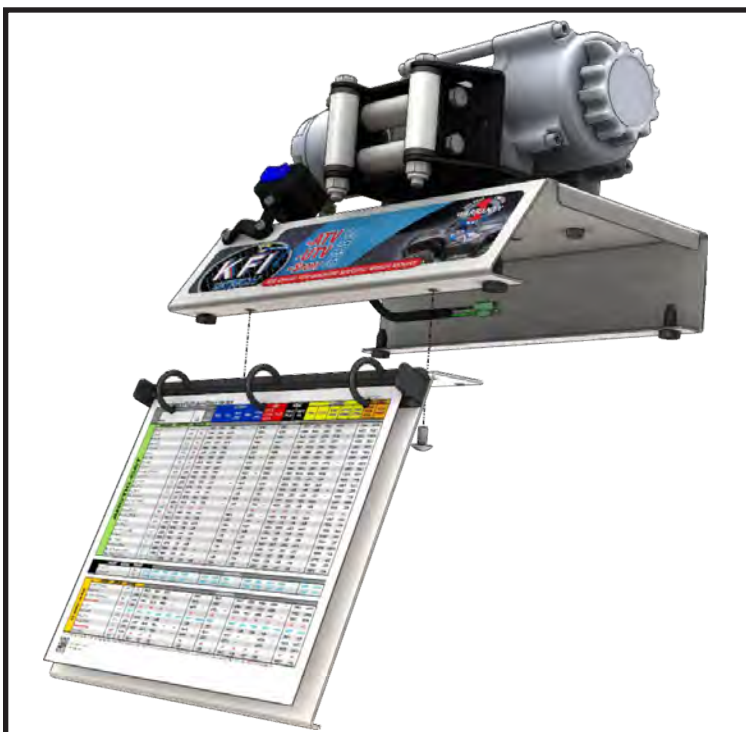

“Figure 3” Binder Display Bracket Install

5. Do not cut the Rubber Band on the cable as this will allow the cable to unravel when customers want to try out the Free Spool Knob. Instead use one of the supplied Zip Ties to wrap around the spool and through the loop as shown in Figure 4.
6. Assemble the hook and KFI pull strap to the winch cable loop using the included Zip Ties as shown in Figure 4.

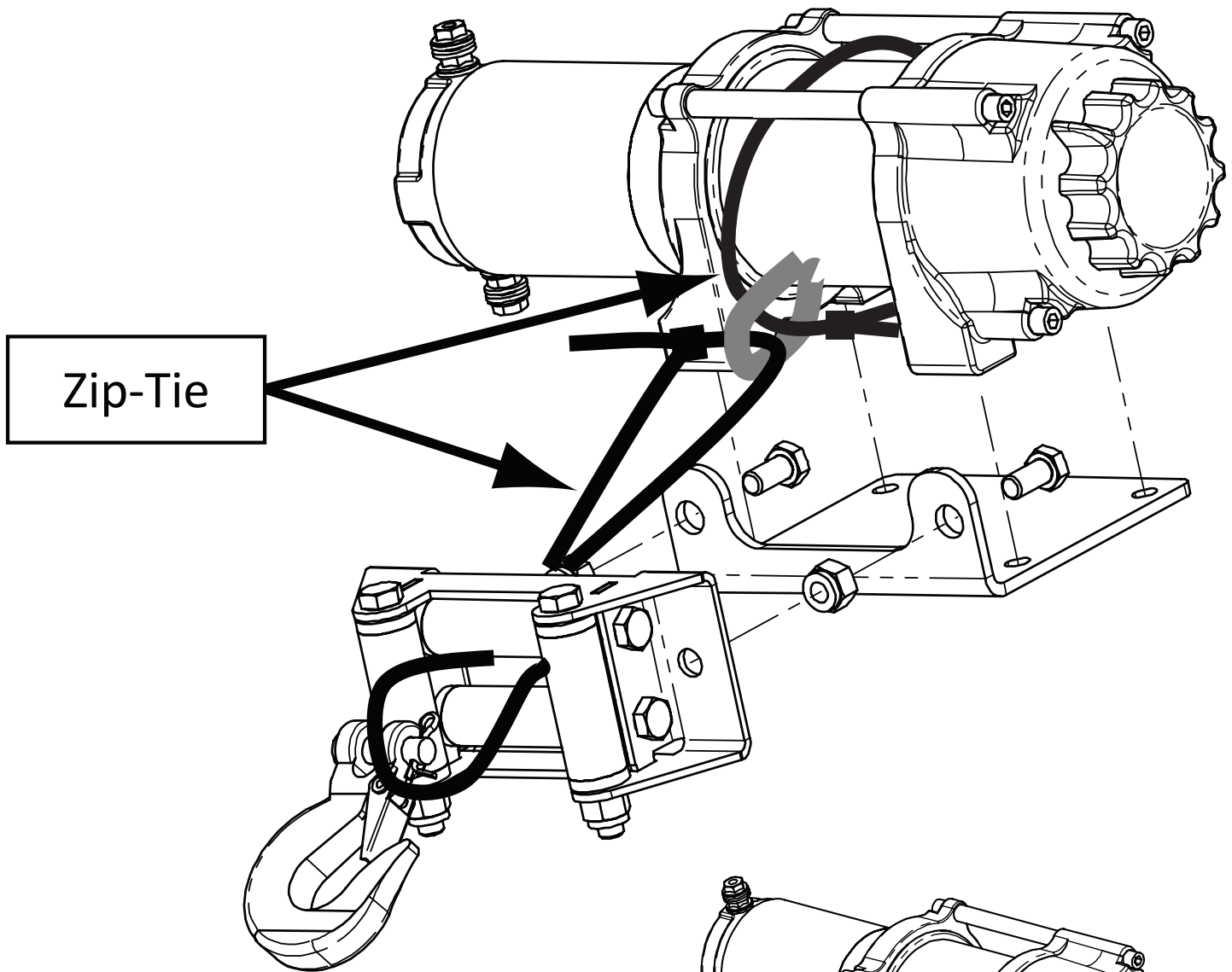

“Figure 4” Zip Tie Install

