

SINGLE DEALER WINCH DISPLAY

Display PART # 110565
 Hardware Kit: HK-073

Kit Components:

| Qty. | Part Description |
|--------|-------------------------------|
| 1..... | Winch Display Plate |
| 1..... | Winch Display Slat Wall Plate |
| 2..... | Zip Tie |
| 4..... | Spacer |
| 4..... | 5/16"-18 Hex Nut |
| 4..... | M8-1.25 x 45mm Bolt |
| 1..... | 5/16" USS Flat Washer |
| 4..... | 5/16" Split Lock Washer |

INSTALLATION INSTRUCTIONS:

1. Assemble the roller fairlead to the fairlead bracket using the items included in your winch box. (See Figure 1&4)
2. Assemble winch to display using the supplied longer M8 bolts and spacers, see Figure 2, use washers and lock washers supplied with winch if needed. If installing a wide winch use the supplied washer (A) in the larger hole, if installing the ST15 this hole will be used for hiding the winch wires. The holes (B) are for hiding wiring.
3. Install contactor and mini-rocker switch using hardware provided with your winch. (See Figure 2) When installing the mini-rocker place the other half of the handle bar bracket to the back side.
4. Place slat wall plate in desired position on slat wall and install display to slat wall plate as shown in Figure 3.

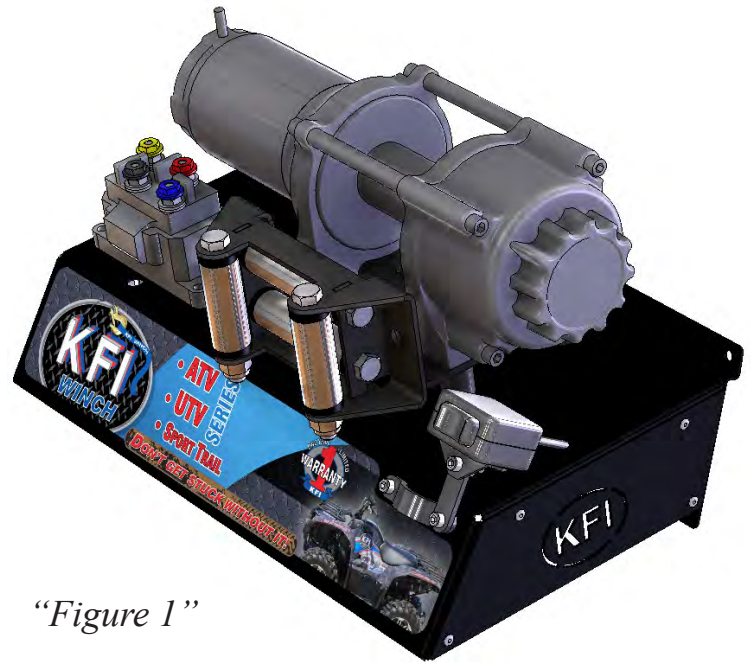

"Figure 1"

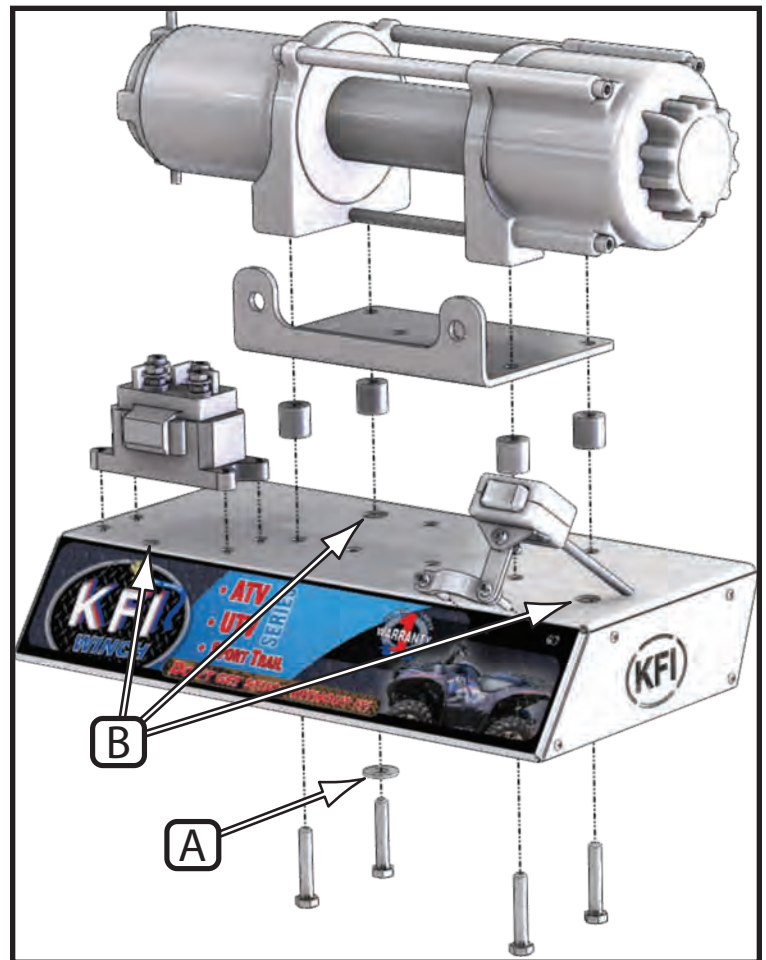

"Figure 2" Winch Install

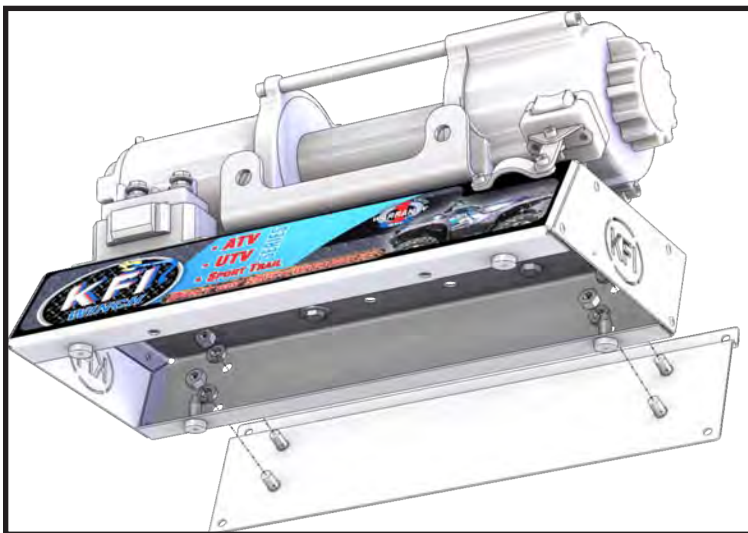

"Figure 3" Slat Wall Plate Install

5. Do not cut the Rubber Band on the cable as this will allow the cable to unravel when customers want to try out the Free Spool Knob. Instead use one of the supplied Zip Ties to wrap around the spool and through the loop as shown in Figure 4.
6. Assemble the hook and KFI pull strap to the winch cable loop using the included Zip Ties as shown in Figure 4.

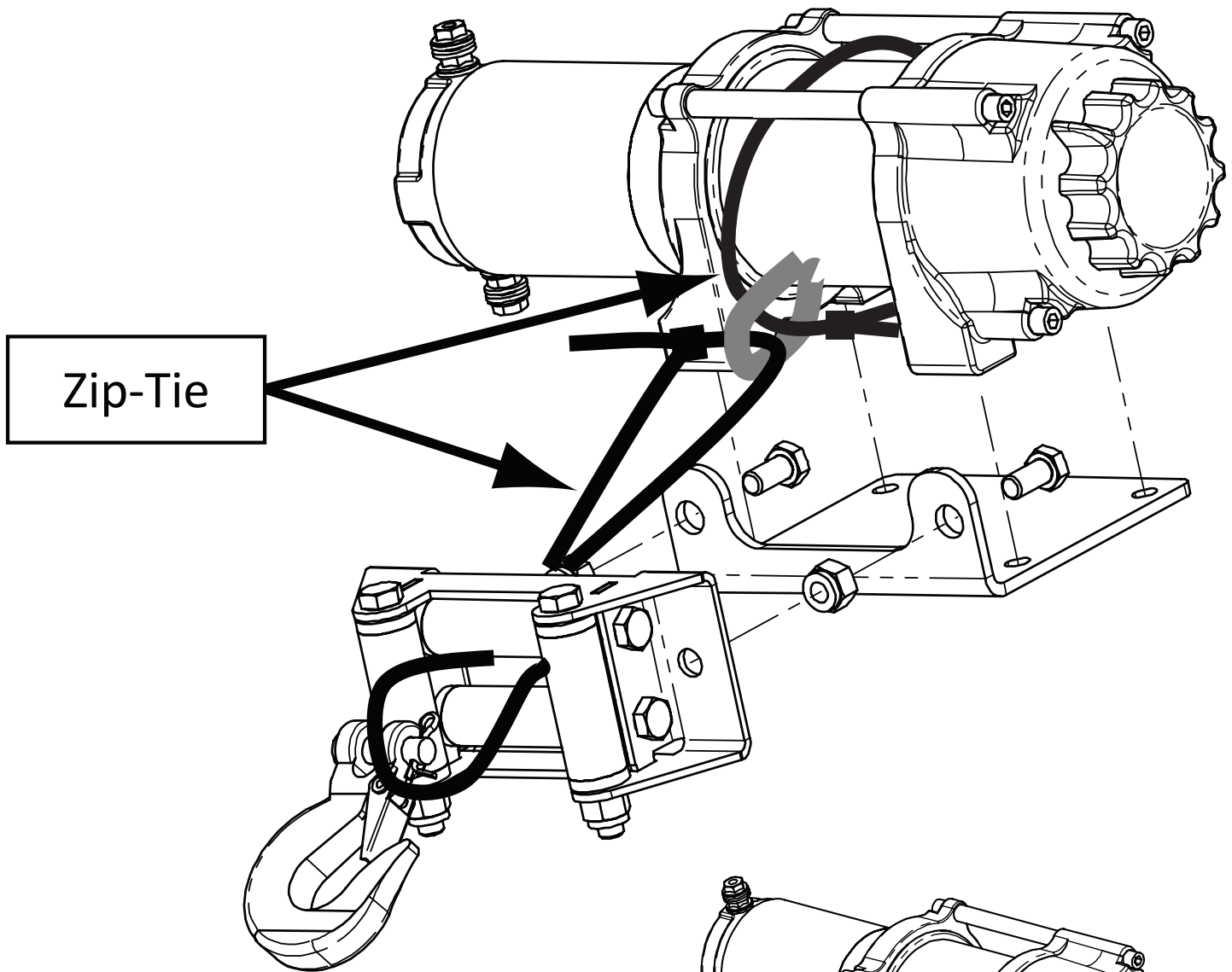

“Figure 4” Zip Tie Install

