

UNIVERSAL POLY WEAR BAR

Plow Accessory PART#WB-POLY

Kit Components:		
Item #	Qty.	Description
1	1	Poly Wear Bar

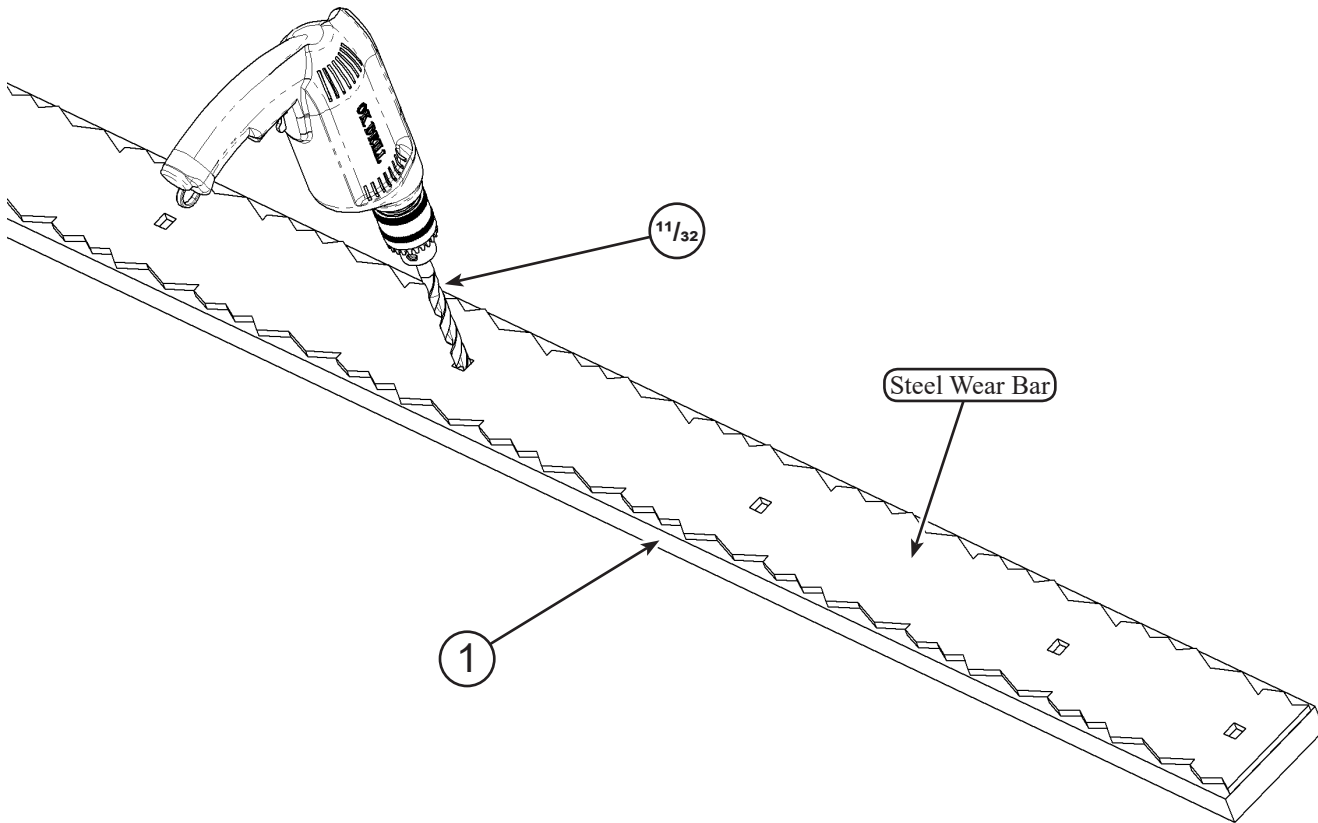

Note: Thoroughly read through and understand the instructions before installing.

Installation Instructions

1. Remove the original wear bar from your blade. Lay the original wear bar on top of the Poly Wear Bar (1). If your original blade is worn down, be sure that the bolt holes are in the center of the Poly Wear Bar (1).
2. Mark each hole used for your blade and mark the edge of the wear bar if it needs to be shortened.
3. Drill all marked holes with an 11/32" drill bit and cut the wear bar to length if your original wear bar is smaller than the Poly Wear Bar (1).
4. Use 5/16"-18 X 1.5" bolts through the Poly Wear Bar and Blade, secure with Lock Nuts. *Hardware Kit (HK-416) Sold Separately*

Note* If you ordered a 1" thick wear bar and 1.5" long bolts, the holes would need to be counterbored 1/4"

