

MOTOR-AS35 INSTALLATION MANUAL

Winch Motor

PART #Motor-AS35

Hardware Kit: N/A

Kit Components:

Qty. Part Description

1..... Bushing (E)

1..... Motor (F)

Not Included

1..... Spring (A)

1..... Coupling, II (B)

1..... Spring, Coupling (C)

1..... Coupling, I (D)

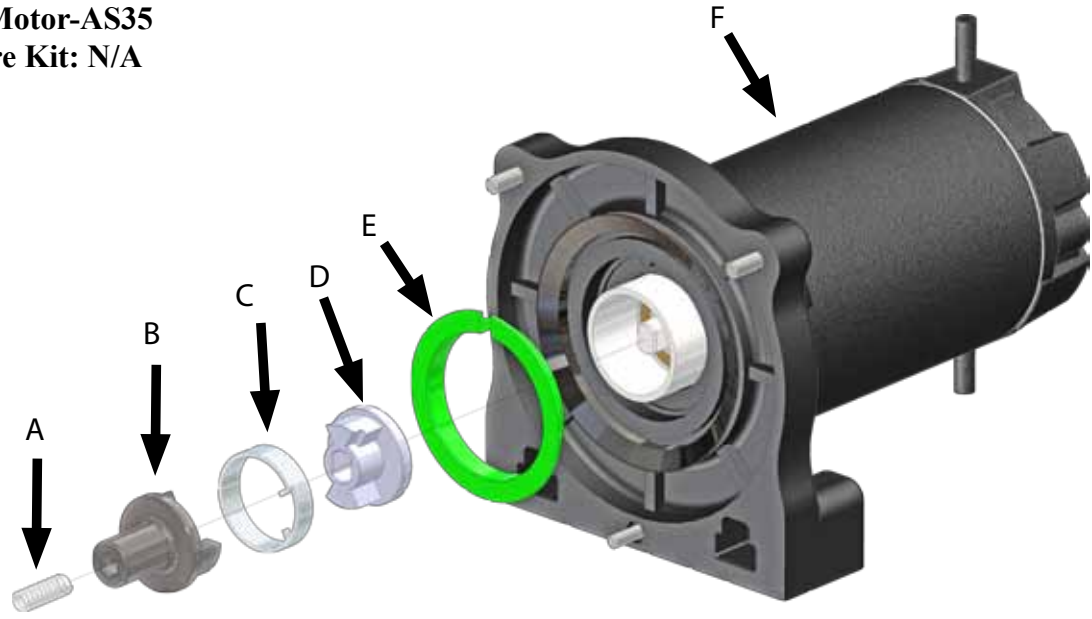

NOTE:

Components A, B, C, and D will need to be taken from original motor. If Bushing (E) is not preinstalled, reuse the original.

“Figure 1” Exploded View

INSTALLATION INSTRUCTIONS:

1. Remove the three bolts that attach the motor, as shown in Figure 2.
2. Remove the Spring (C), Coupler I (D), and Bushing (E) from your original motor. The Bushing has a press fit and can be gently pryed out without damage.
3. Press the plastic bushing (E) into your new motor if not preinstalled. Shown in Figure 3.

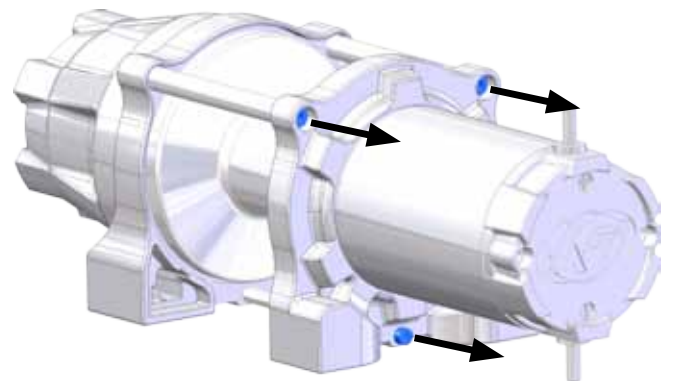

“Figure 2”

Note: It is very important that the couplers are installed correctly so that your winch performs as it should. there are cut-outs on both couplers that the spring sits in.

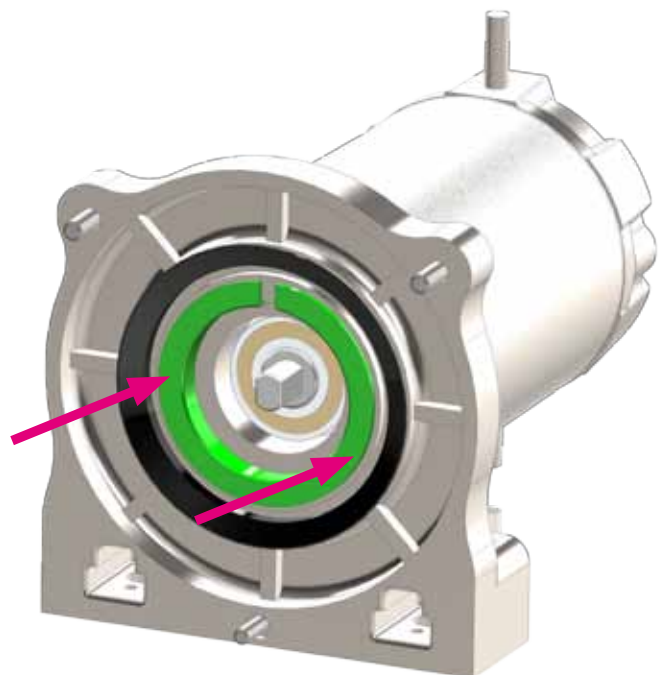
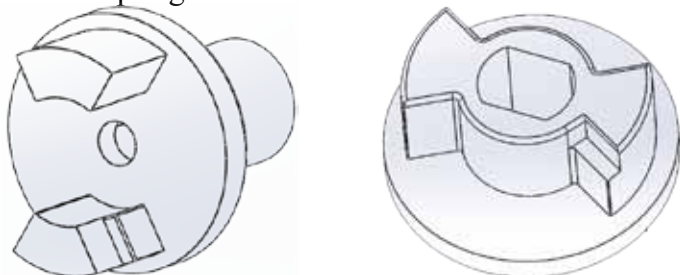

“Figure 3”

MOTOR-AS35 INSTALLATION MANUAL

INSTALLATION INSTRUCTIONS CONTINUED:

4. Install Coupler I (D) onto the motor shaft



Verify that the cutout on Coupler II (B) lands over the spring tab.

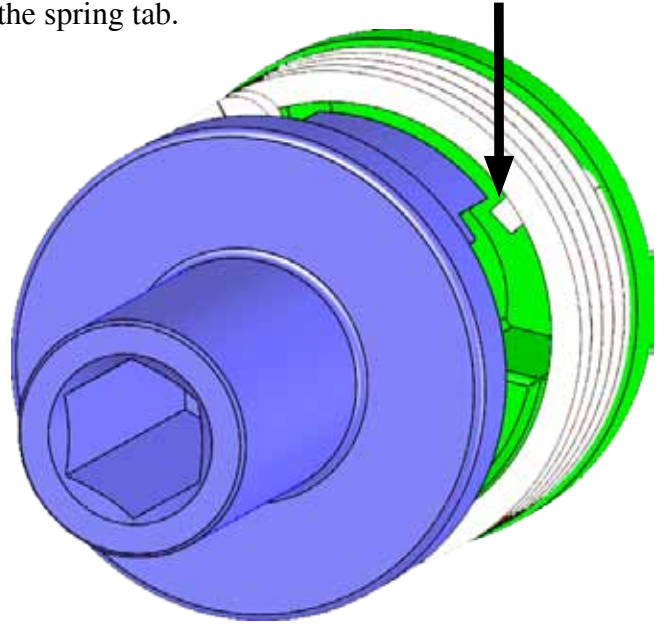

5. Install the Couling spring (C) in the space between the coupler (D) and the housing. Orientate the spring and coupler so the tab coming off the spring lands in the cutout in the coupler.

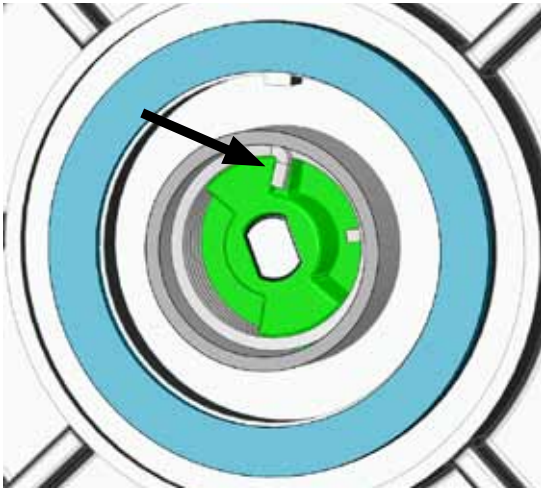

7. Insert the small Spring (A) into the hex opening on the Coupler II (B).

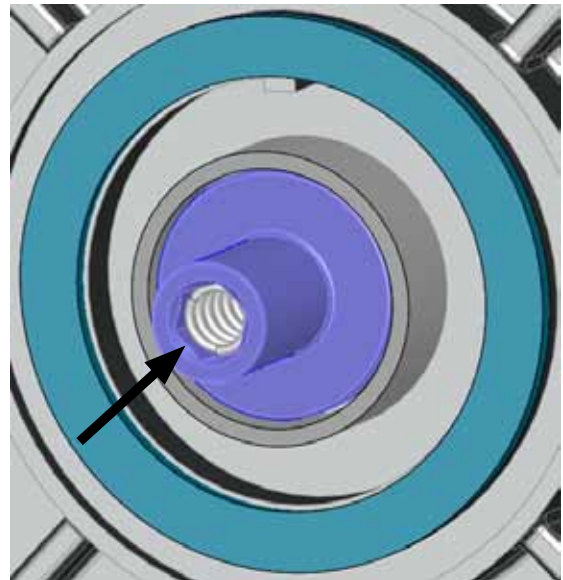

6. Insert Coupler II (B) so that the flange with the cutout sits over the the spring tab on the bottom of the spring

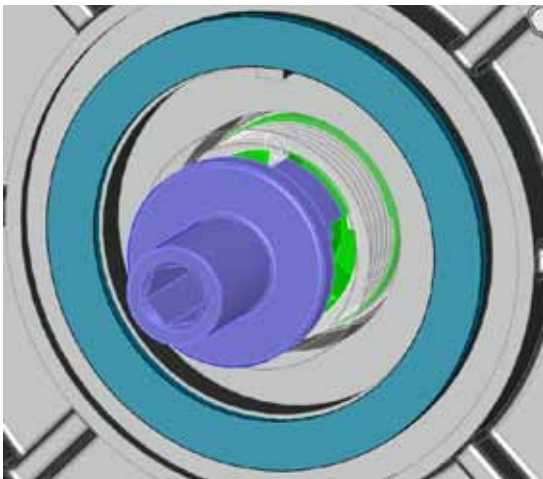

8. You can now install the new motor on your winch with the three bolts removed in step 1 (Shown in figure 2).

ASP-35 MOTOR INSTALLATION MANUAL

INSTALLATION INSTRUCTIONS (IF NEEDED)

1. After installing the new motor the orientation of it will be wrong.
2. There are two allen head bolts (1) on the end-cap of the motor that need to be removed.
3. With the bolts removed you can rotate the end-cap and the motor housing at the same time clockwise 90° as shown in figures below. (*Note: There are bolt hole at every 45° increments*)

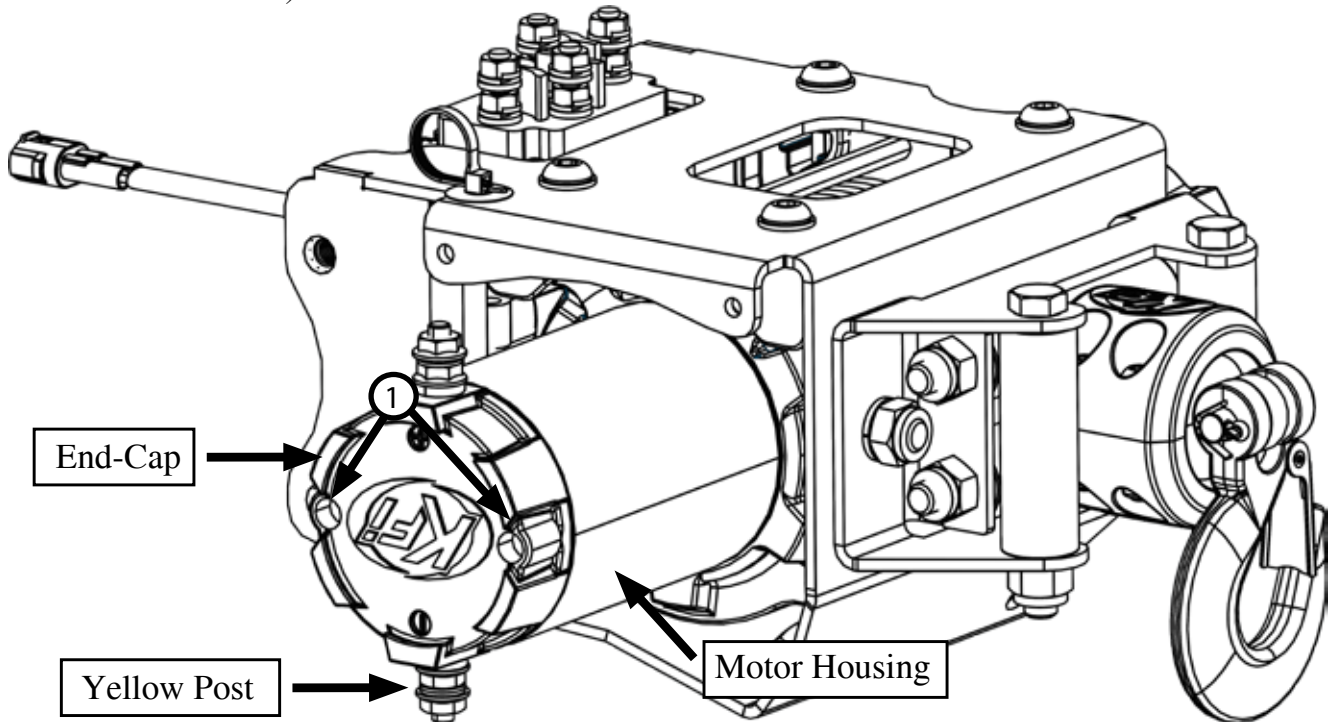

4. Once the motor has been rotated 90° make sure that the seals are still in place between the (motor and the end-cap), and the (motor and winch).
5. Re-insert the two allen bolts previously removed and tighten down.

