

ASSAULT WINCH LEAD ROTATION

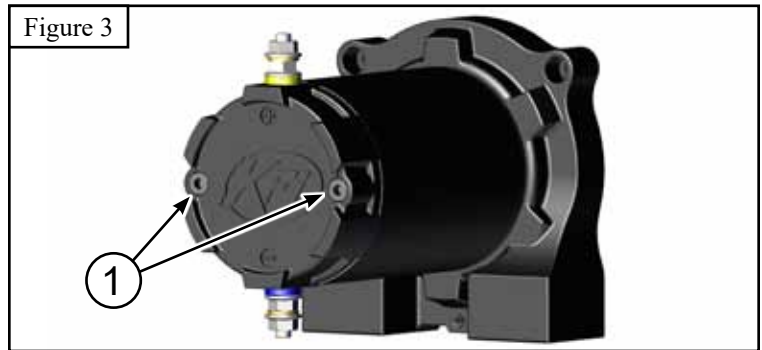

Note: The brushes in the end cap have springs behind them. If they fall out of their location, you may need to separate the cap (2) and armature housing (3) to get everything lined back up. If possible, don't pull the housing/cap too far off of the armature so the brushes and springs stay in place.

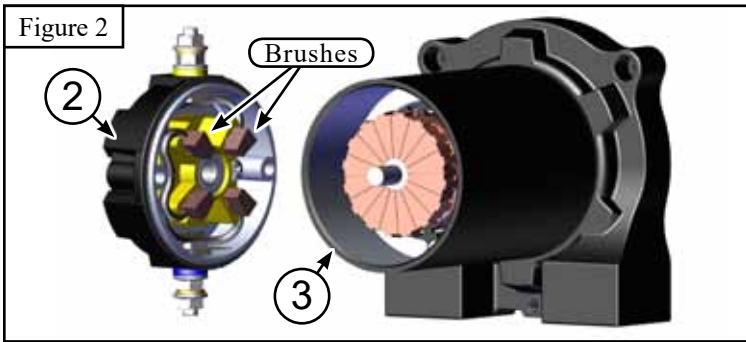
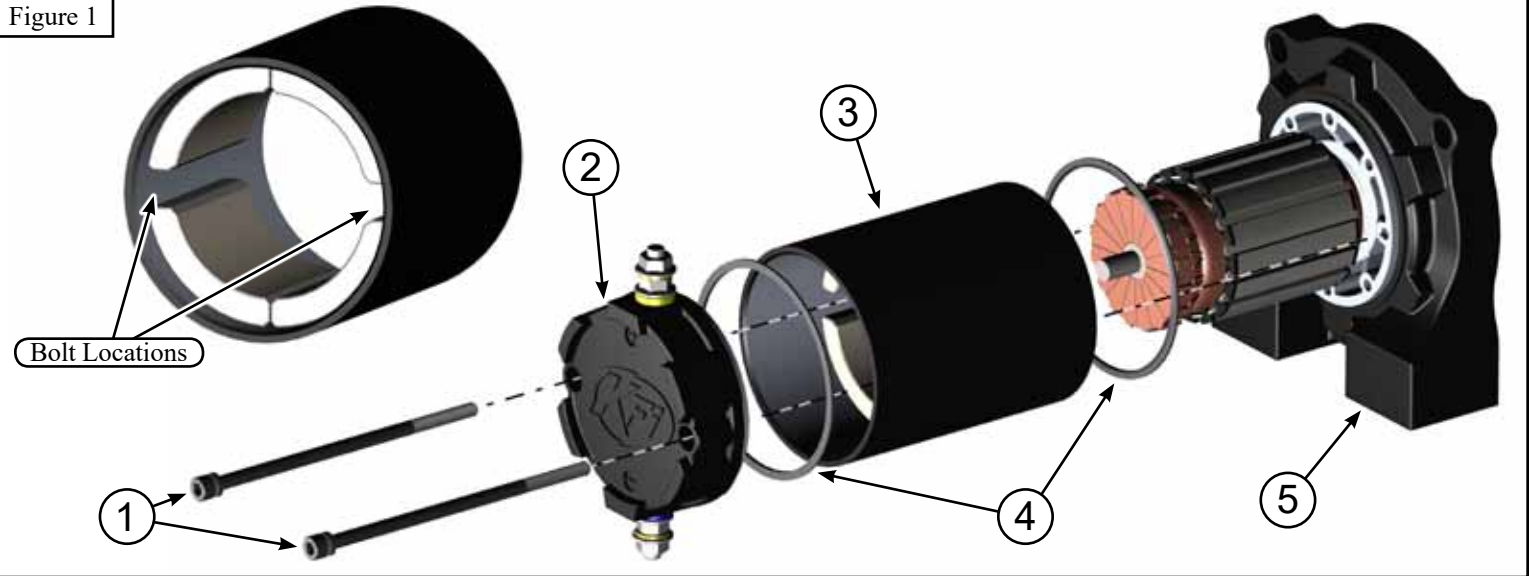

Rotation Instructions

1. Using a 4mm allen wrench, unscrew the 2 bolts (1) located on the back of the motor as shown in Figure 3.
2. Once completely unthreaded, carefully pull the armature housing (3) away from the base of the motor (5) **as little as possible**. The cap (2) and housing (3) can remain connected to each other as shown in Figure 4.
3. Rotate the Armature housing and cap together in 45° increments as shown in Figure 4.
4. Ensure that the seals (4), shown in Figure 1, are in the correct location and install the Armature housing and end cap assembly onto the motor base as shown in Figure 5. Tighten bolts (1).

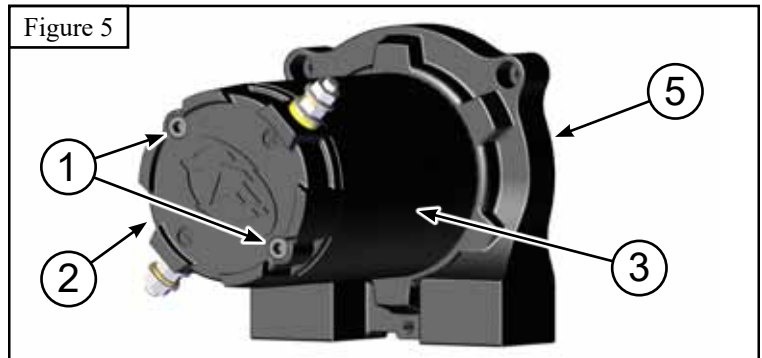

Note: If you put pressure on the bolts (1) as you reinstall, you should be able to feel the hole locations before completely pressing it on. Once the housing is pressed on, it can't be spun.

