

Bobcat & Polaris Ranger Full Size Rear Bumper

PART # 101425

Kit Components:

Item #	Qty.	Description
1	1	Bumper
2	2	Bumper Bracket Driver & Passenger
3	2	Bumper Hanger Driver & Passenger
4	4	Bumper Tube Cap
5	1	HK-344
5.1	8	3/8"-16 X .75 Carriage Bolt GR5 Zinc
5.2	8	3/8"-16 Hex Flange Nylock Nut GR5 Zinc
5.3	6	5/16"-18 X .75 Carriage Bolt GR5 BLK
5.4	6	5/16"-18 Hex Flange Nylock Nut GR5 Zinc
5.5	2	5/16" X 1.00 Hex Flange Bolt Self-Tapping Type F Zinc (NOT USED)
5.6	2	1/4" X .75 Hex Flange Bolt Self-Tapping Type F Zinc (NOT USED)

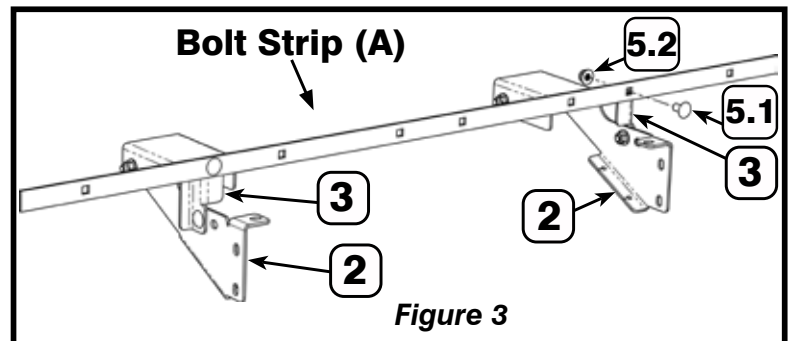
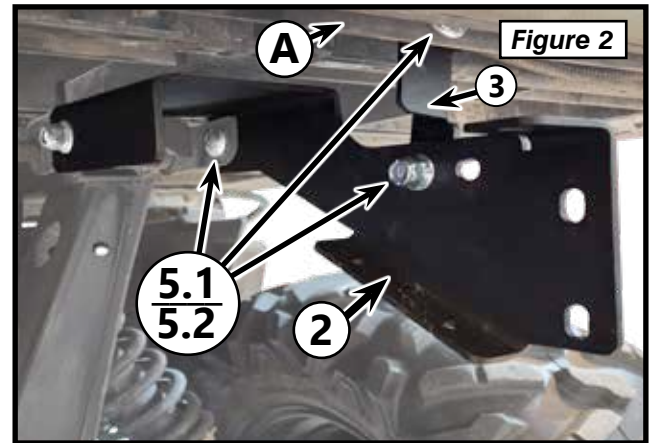
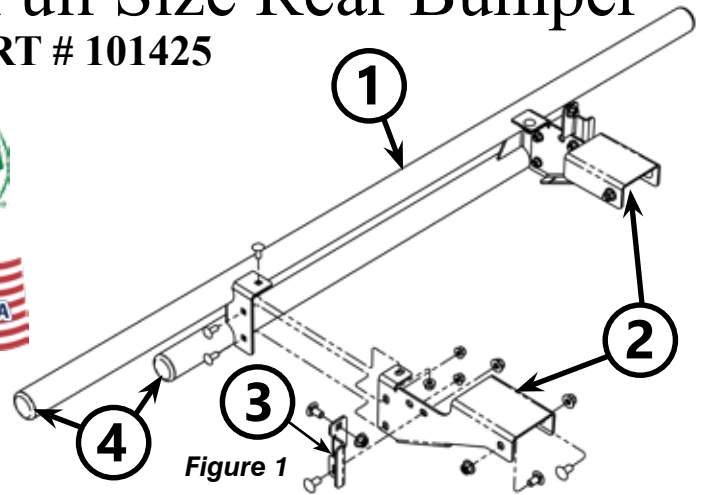

Installation:

1. Assemble tube caps (4) to bumper tubes as shown in [Figure 1](#).
2. Locate the bolt strip with square cutouts (A) shown in [Figure 2 & 3](#) at the rear of the dump box
3. Position each of the bumper hangers (3) according to diagrams shown in [Figures 1,2&3](#). Loosely bolt to strip using two 3/8" x .75 Carriage Bolts (5.1), and 3/8" Hex Flange Nuts (5.2) as seen in [Figure 2&3](#).
4. Hold passenger side bumper bracket (2) in place over bed hinge and use two 3/8" x .75 Carriage Bolts (5.1) and 3/8" Hex Flange Nuts (5.2) to bolt brackets to the bed hinge as shown in [Figure 2](#). Use one 3/8" x .75 Carriage Bolt (5.1) and 3/8" Hex Flange Nut (5.2) to bolt brackets to bumper hanger. Repeat step 4 for driver side.
5. Bolt bumper (1) to bumper brackets (2) using six 5/16" X .75 Carriage Bolts BLK (5.3) and 5/16" Hex Flange Nylock Nuts (5.4) [Figure 4 & 5](#).
6. Level bumper and evenly tighten all hardware

