

KAWASAKI MULE PRO MX REAR BUMPER

Kit Components: PART # 101710

Item #	Qty.	Description
1	1	BUMPER
2	1	PASSENGER SIDE BRACKET
3	1	DRIVERS SIDE BRACKET
4	4	BUMPER CAPS
5	1	HK-356
5.1	8	5/16"-18 X 3/4" CARRIAGE BOLT-BLACK
5.2	8	5/16"-18 HEX FLANGED NYLOCK NUT
5.3	4	M8-1.25 X 25 HEX BOLT
5.4	4	M8 LOCK WASHER
5.5	4	M8 FLAT WASHER

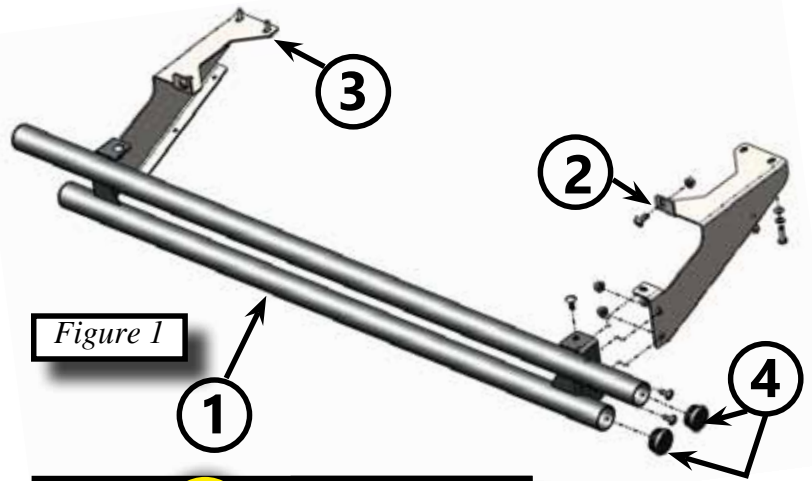

Figure 1

INSTALLATION INSTRUCTIONS:

- Note: Make sure all of the hardware needed to complete this mount is in the package. Read through and understand the instructions before installing.

- Assemble tube caps (4) to bumper tubes as shown in Figure 1.
- Place bumper bracket (2) in place on passenger side. Line up with the two existing threaded M8 holes. Use two M8 x 25 Hex Bolts (5.3), M8 Lock Washers (5.4) and M8 Flat Washer (5.5) as shown in Figure 2
- Next install one 5/16" x .75 Carriage Bolt BLK (5.1) and 5/16 Hex Flange Nylock Nut (5.2) as shown in Figure 3.
- Repeat steps 2-3 on drivers side. Tighten all hardware evenly.
- Bolt bumper (1) to bumper brackets (2&3) using six 5/16" x .75" Carriage Bolts BLK (5.1) and 5/16" Hex Flange Nylock Nuts (5.2) Figure 4.



Figure 2

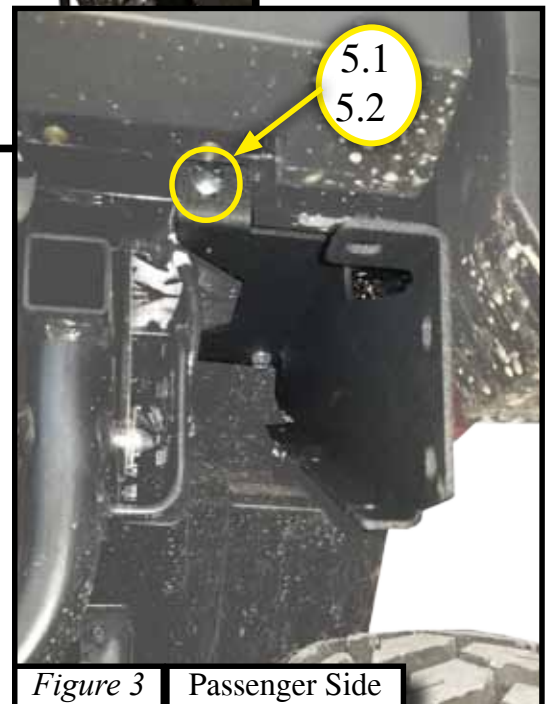

Figure 3 Passenger Side

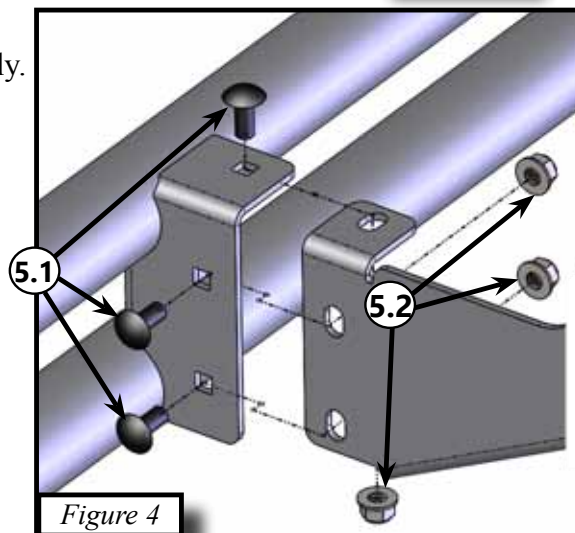

Figure 4

- Tighten all hardware evenly.