

YAMAHA RMAX

Front Receiver

PART #101870

Kit Components:		
Item #	Qty.	Description
1	1	Receiver
2	1	Hardware Kit (HK-388)
2.1	4	3/8"-16 x 1.00 Hex Flange Bolt
2.2	4	3/8"-16 Hex Flange Nylock Nut
2.3	2	5/16"-18 x 1-5/8" x 2 3/16" x 1" Thread U-Bolt
2.4	4	5/16"-18 Hex Flange Nylock Nut

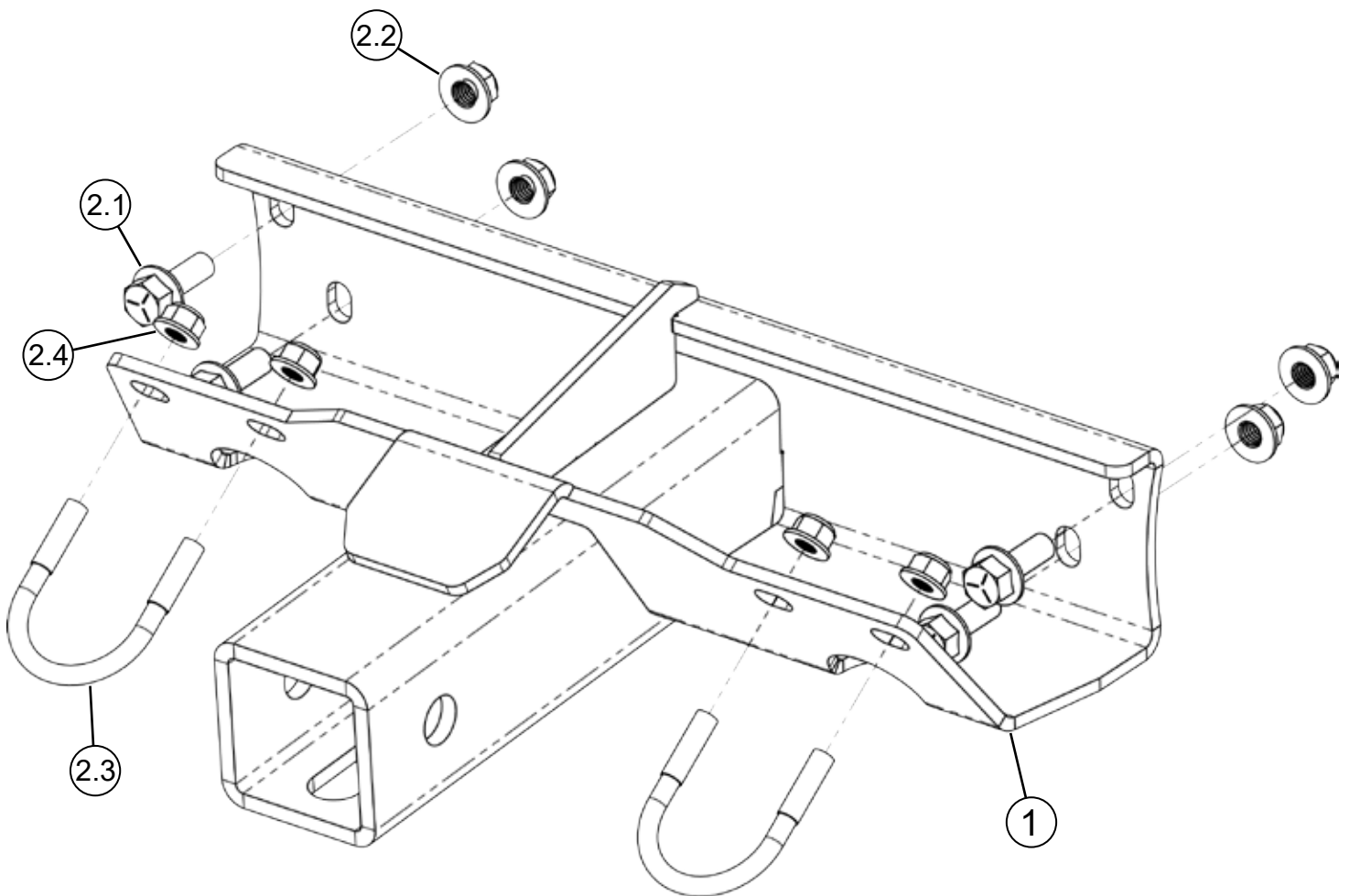

INSTALLATION INSTRUCTIONS

Note: Make sure all hardware needed to complete this mount is in the package. Thoroughly read through and understand the instructions before installing.

1. Remove the front portion of the skid plate on the machine by removing bolts (A) as shown in **Figure 1**. Set bolts aside as they will be reused.
2. Remove the front bumper by removing bolts (B & C) on both side as shown in **Figure 2**. Set bolts aside as they will be reused.
3. Set front receiver (1) in place lining up holes in receiver to holes (D) in frame as shown in **Figure 3**. Loosely secure receiver (1) using bolts (2.1) and nuts (2.2) as shown in **Figure 4**.
4. Reinstall front bumper using bolts (B & C) previously removed in step 2.
5. Secure front of receiver (1) to front bumper using U-Bolts (2.3) and nuts (2.4) as shown in **Figure 4**.
6. Tighten all hardware evenly.
7. Cut the receiver hole into the plastic skid plate using template on the next page.
8. Reinstall the front portion of the skid plate previously remove in step 1 using bolts (A).

Figure 1

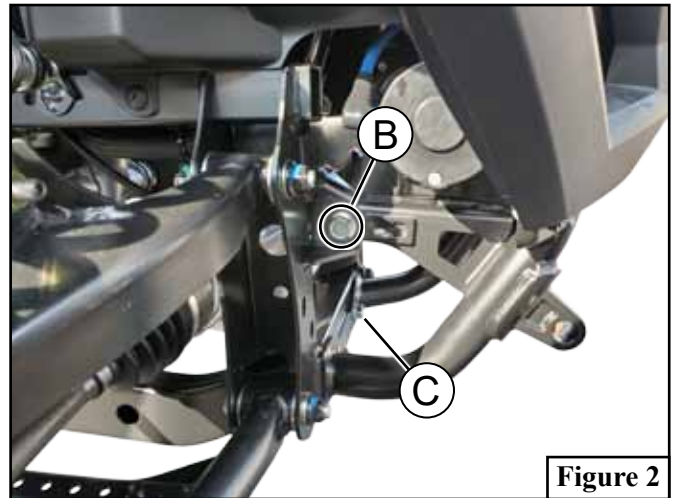
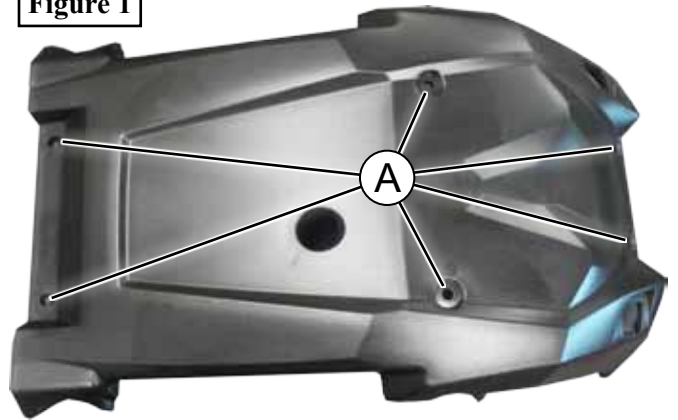

Figure 2

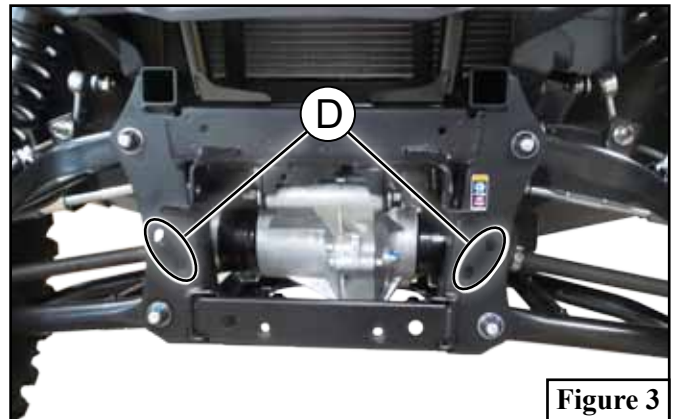

Figure 3

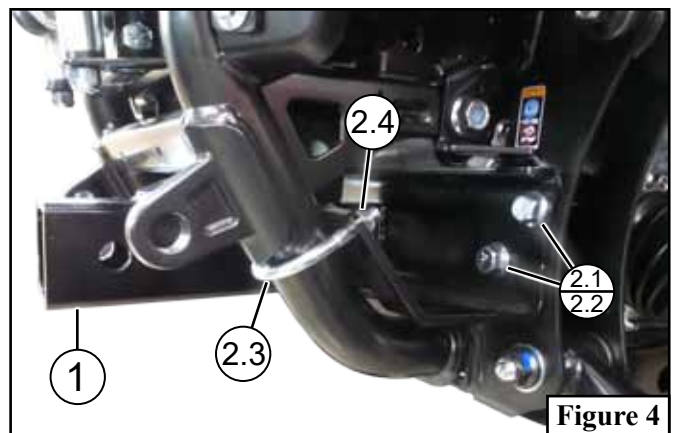
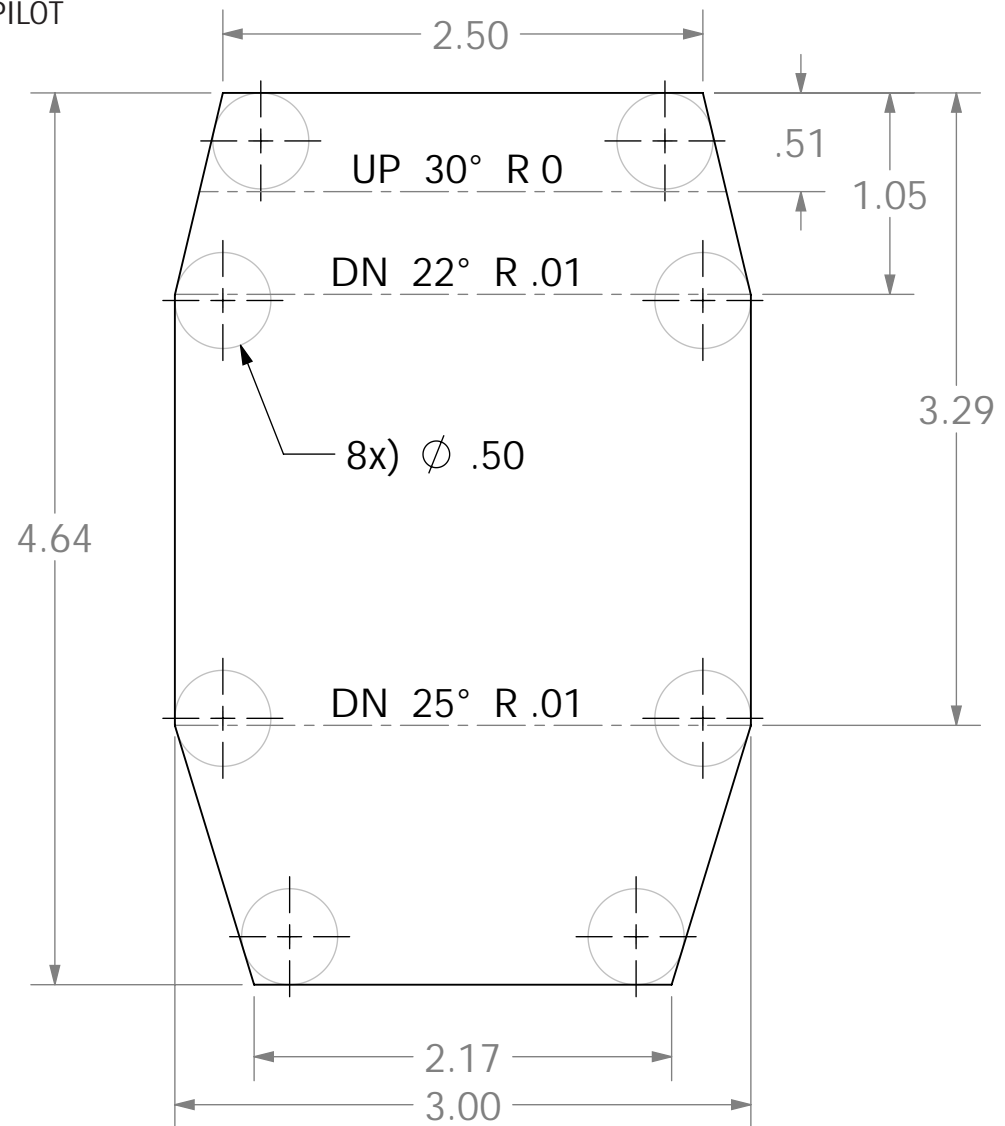

Figure 4

101870 YAMAHA RMAX - FRONT RECEIVER CUTOUT TEMPLATE

- VERIFY TEMPLATE SIZE IS CORRECT BY MEASURING THE 3" DIMENSION GIVEN.
- CUT OUT TEMPLATE ALONG CUT LINE.
- PLACE TEMPLATE ONTO THE SKIDPLATE AS SHOWN IN FIGURE 1.
LINE UP TOP OF TEMPLATE WITH FIRST LINE ON SKIDPLATE BETWEEN BOLT HOLES (SEE ARROW 1).
- MARK EACH POINT AND DRILL WITH A SMALL DRILL BIT TO MAKE A PILOT HOLE THEN DRILL TO SIZE WITH A 1/2" DRILL BIT.
- CUT FROM HOLE TO HOLE TO REMOVE SECTION AND ALLOW CLEARANCE FOR FRONT RECEIVER TUBE.

ARROW 1



"FIGURE 1"