

YAMAHA KODIAK

Winch Mount

PART # 101920

Hardware Kit: HK-340

Kit Components:

Item	Qty.	Description
1	1	Winch Mount
2	1	Winch Spacer Plate
3	2	M6-1.00 X 30MM HEX BOLT GR8.8 ZINC
4	2	M6 FLATWASHER ZINC
5	2	M6 HEX NUT NYLOCK GR8.8 ZINC
6	4	M8-1.25 x 30MM HEX BOLT GR8.8 ZINC
7	2	M8-1.25 HEX NUT NYLOCK GR8.8 ZINC
8	2	1/4" USS WASHER ZINC

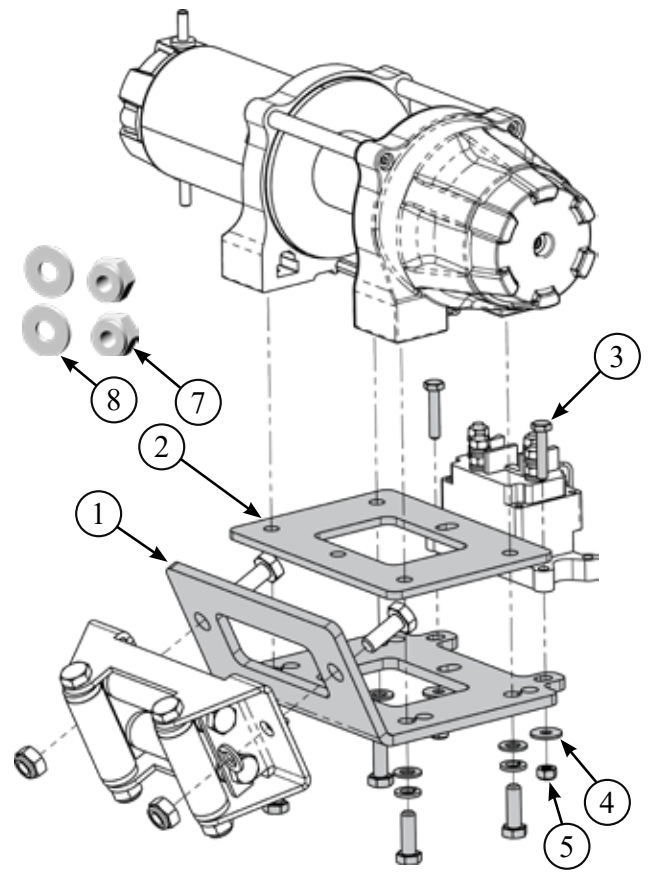

“Figure 1” Exploded View

INSTALLATION INSTRUCTIONS:

1. Remove four bolts (A) from front skid-plate. Retain bolts for re-use (Shown in figure 2).
2. Remove plastic rivets (C) from headlight bezel. Retain for re-use (Shown in figure 3 & 4).
3. Remove top two bolts (B) from the front rack. (Shown in figure 3).



“Figure 2”

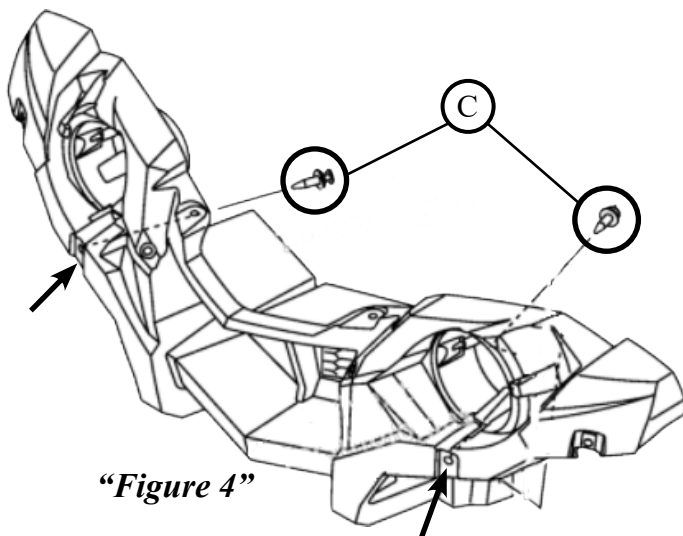

“Figure 4”



“Figure 3”



INSTALLATION INSTRUCTIONS:

4. Remove two bolts (D & E) from each side of the bumper. Remove the bumper from the machine after removal of these bolts. Retain bolts for re-use (Shown in figure 5).

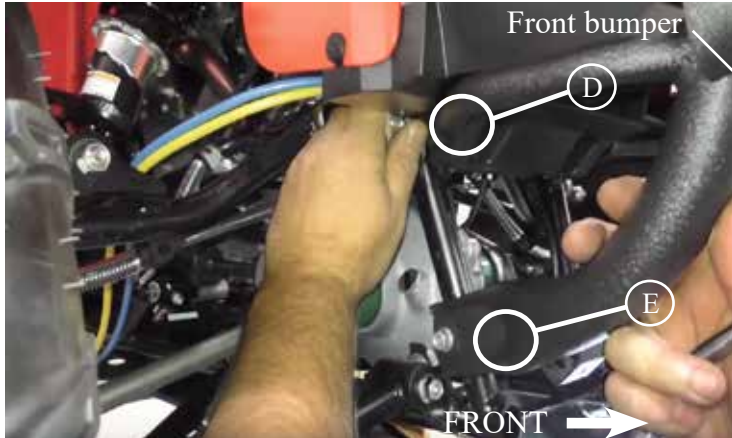

“Figure 5”

5. Attach fairlead to winch mount with hardware provided with your winch (Shown in figure 6).



“Figure 6”

Note: Some winches may require additional space between the mount (1) and bumper. Place the winch spacer plate (2) between the mount and winch if needed. M8x30mm bolts (6) supplied if spacer plate is used.

6. Place winch mount (1) onto the bumper. Place the spacer (2) on top of mount if your winch requires the additional space to clear the bumper tubing on the bottom side (Shown in figure 7).



“Figure 7”

7. The winch power leads on some winches may need to be rotated to prevent contact with the bumper frame (Shown in figure 8). See last page for lead rotation instructions.

8. Place winch onto mount and tighten in place with hardware supplied with your winch (Shown in figure 8 and 9).

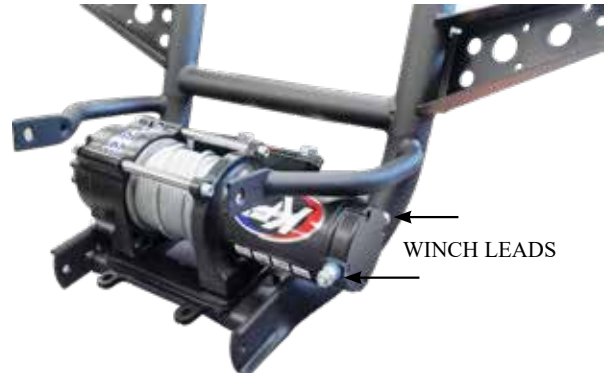

“Figure 8”



“Figure 9”

Note: if mounting a two hole winch you will use the centered holes on the winch mount and Kodiak bumper. Place M8 bolts from the top through the winch, winch mount, and bumper. Place a 1/4” USS washer (8) onto each bolt and fasten with M8-1.25 hex nuts (7).



9. Install your contactor on the mount behind the winch with the two included M6-1.00 x 30MM hex bolts (3), M6 washers (4) and M6 nylock nuts (5),(Shown in figure 10).



“Figure 10”

10. Verify all winch, contactor, and fairlead hardware has been tightened. Place the bumper assembly back up to your machine frame. Reinstall the lower two factory M8 hex bolts (E) removed in step 4. Do not tighten yet (Shown in figure 11).



“Figure 11”

11. Rotate the bumper assembly down to access the contactor. Locate the factory pre-ran Red/Black power and ground wires attached to the radiator hose along the frame under the drivers side front fender (Shown in figure 12). Connect the wires to the corresponding red/black contactor posts (Shown in figure 16).

Connect the shorter red/black wires provided with your winch to the contactor. The black wire will go from the blue post on the contactor to the blue post on the winch and the red wire from the yellow post on the contactor to the yellow post on the winch. (Shown in figure 16)



“Figure 12”

12. Install the Rocker switch to the handle bar and route wires down to the contactor along existing wire bundles. Connect the green and black wires to the contactor. *(Note: make sure all green wires are connected to green and black to black)*. Connect the red wire to a keyed 12 volt power source from the machine. Slide the plastic headlight off cover by removing the two push pins in location (G) Shown in Figure 13. Once the factory harness is exposed you can tap into the PINK (+) wire for your switches shown in Figures 14 & 15.

NOTE: Make sure handlebars can move freely then fasten wires in place.

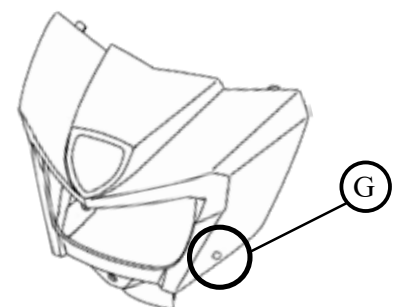

“Figure 13”



“Figure 15”



“Figure 14”

13. Rotate the bumper assembly back up into place and install the upper two M8 hex bolts (D). Tighten all four M8 bolts to secure the bumper assembly (Shown in figure 11).

14. Reinstall bolts into front rack (B), plastic rivets in headlight bezel (C), and four bolts attaching the skid plate. See steps 1-3. (Shown in figure 2, 3 & 4)

15. Locate the factory installed power and ground wires near the battery. The positive wire is found under the drivers side rear fender zip tied to the frame. The negative wire is already routed into the battery compartment under the seat. Connect wires to the respective positive and negative battery terminals (Shown in figure 14 & 15).

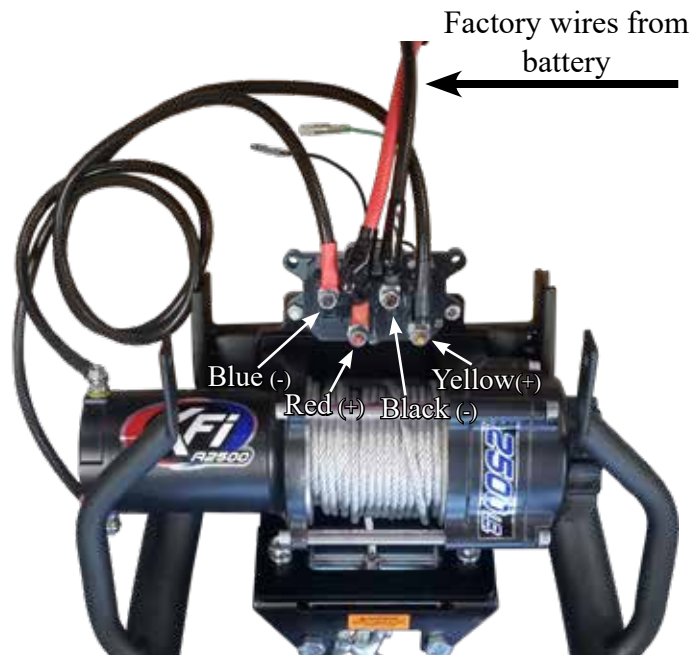

“Figure 16”



“Figure 18”

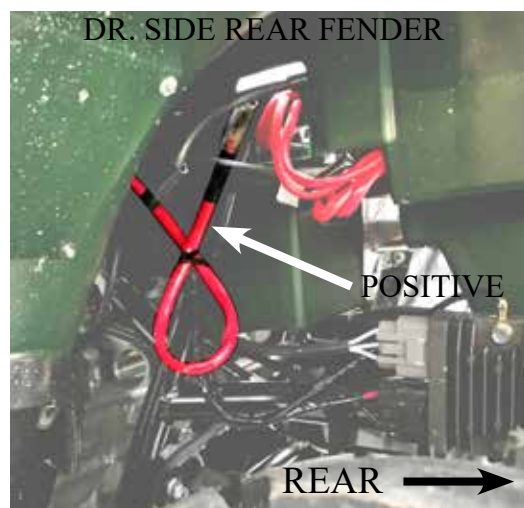

“Figure 17”

WINCH LEAD ROTATION

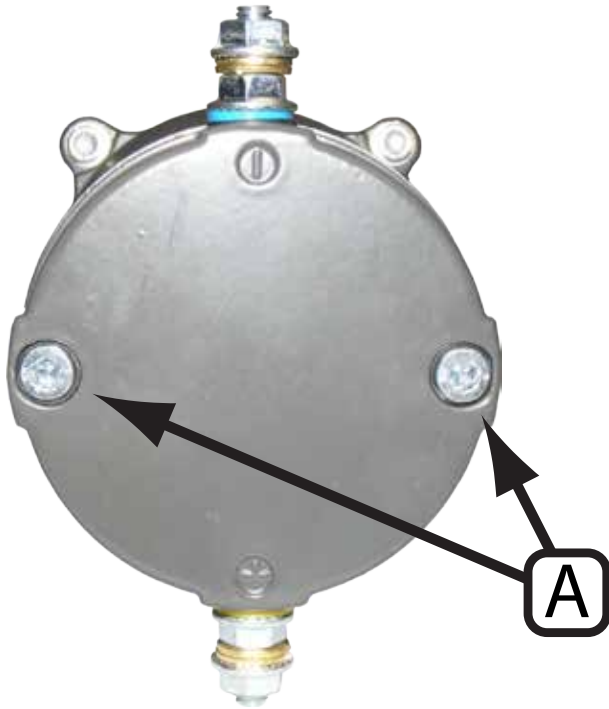

"Figure 1"

1. Remove bolts (A) on motor end cap as shown in Figure 1&2.

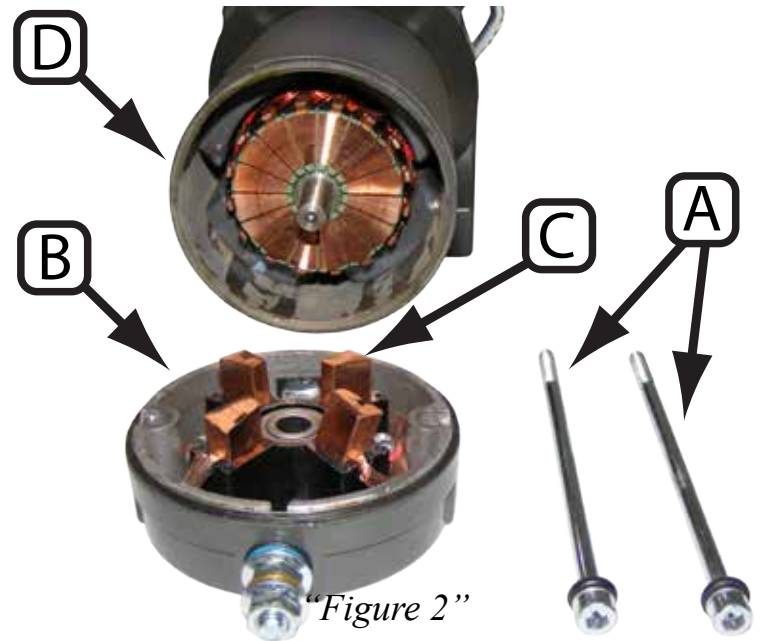

"Figure 2"

2. Remove motor end cap (B) and rotate 90 degrees. Make sure that the brushes (C) are seated properly before reinstalling end cap.

Note: On some winches you may need to rotate the motor housing (D) as the magnets are not always spaced the same.

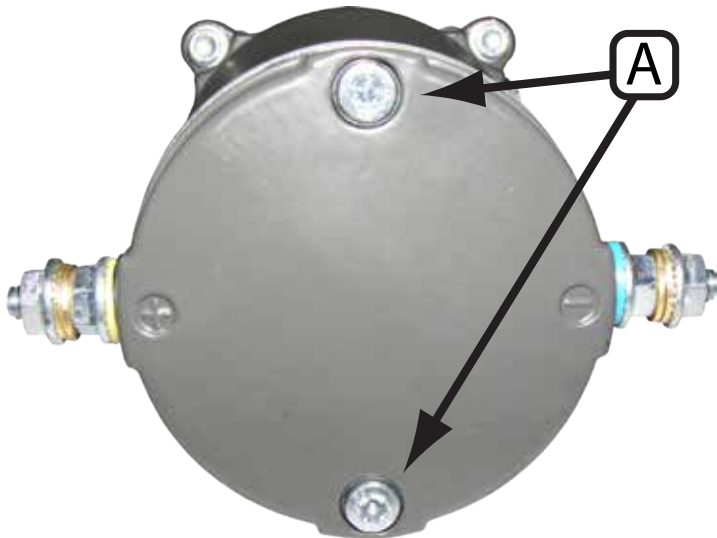

"Figure 4"

3. Reinstall bolts (A) and tighten down.

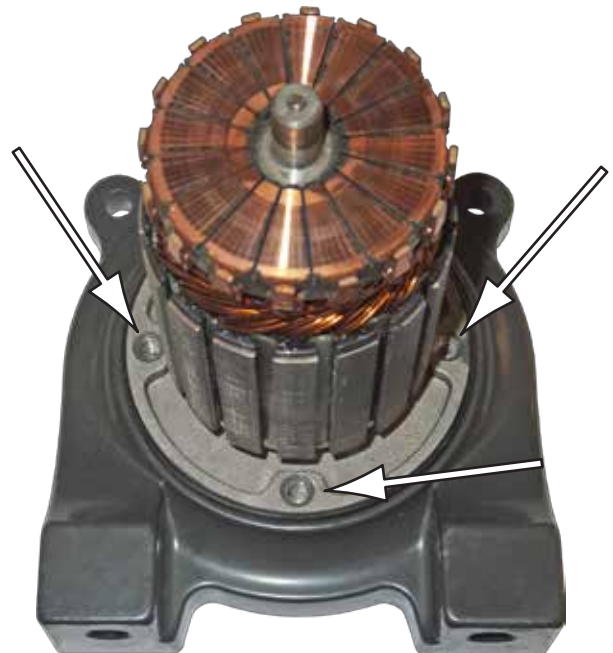

"Figure 3" Threaded Rotation Holes