

CFMOTO CFORCE PLOW MOUNT

Plow Mount Part # 106055 Rev B

Kit Components:

Item #	Qty.	Description
1	1	Plow Mount
2	1	HK-314
2.1	4	M8-1.25 x 30 Hex Bolt GR8.8
2.2	4	M8-1.25 x 35 Hex Bolt GR8.8 (NOT USED)
2.3	4	M8 Lock Washer
2.4	4	M8 Flat Washer

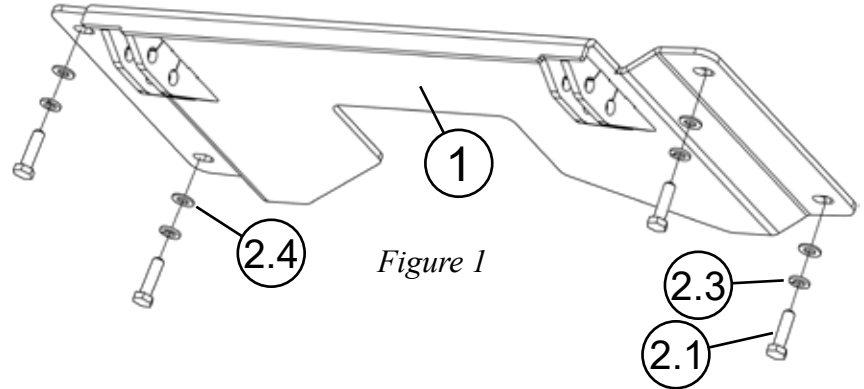

CFORCE 800 INSTALLATION INSTRUCTIONS:

Note: Make sure all of the hardware needed to complete this mount is in the package. Read through and understand the instructions before installing.

1. Remove the outer four bolts labeled (A) on the running board frame tube shown in **Figure 2**.
2. Place the plow mount (1) in its location lining up the bolt holes on the plow mount with the bolt holes from the four bolts (A) removed in step 1 as shown in **Figure 3**.
3. Secure plow mount (1) using M8 Hex Bolt (2.1), M8 Lock Washer (2.3) and M8 Flat Washer (2.4) as shown in **Figure 4**.
4. Tighten all hardware evenly.

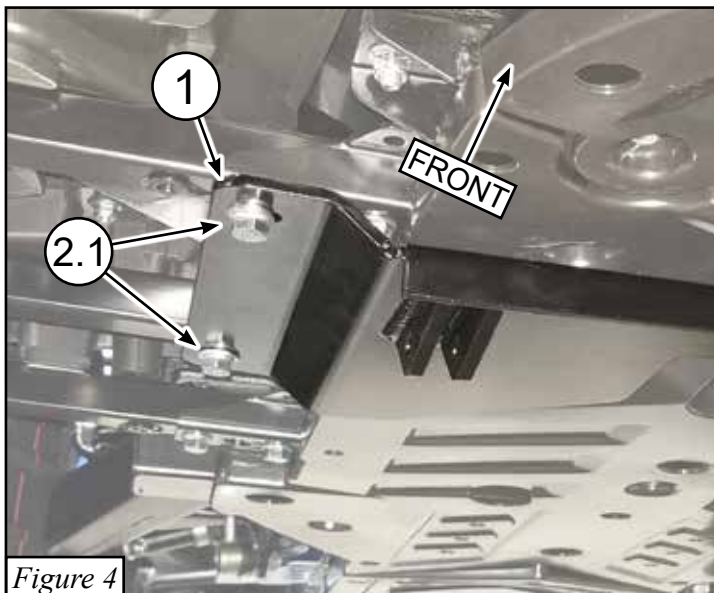
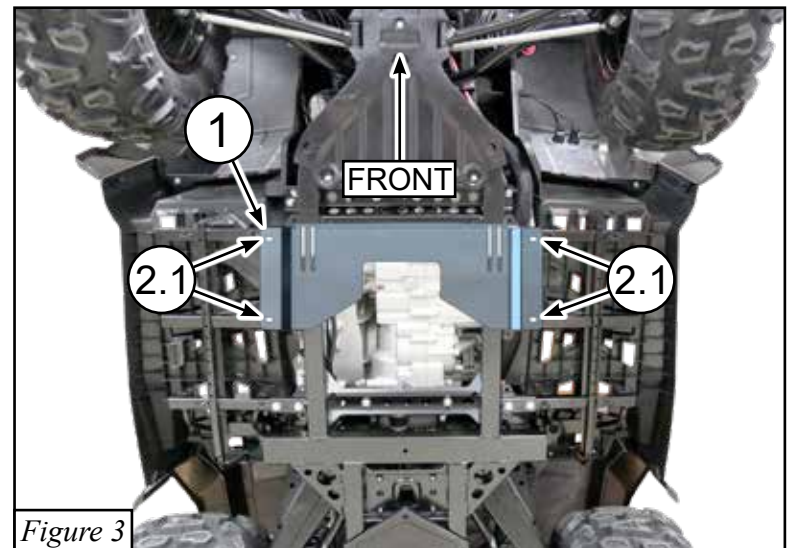
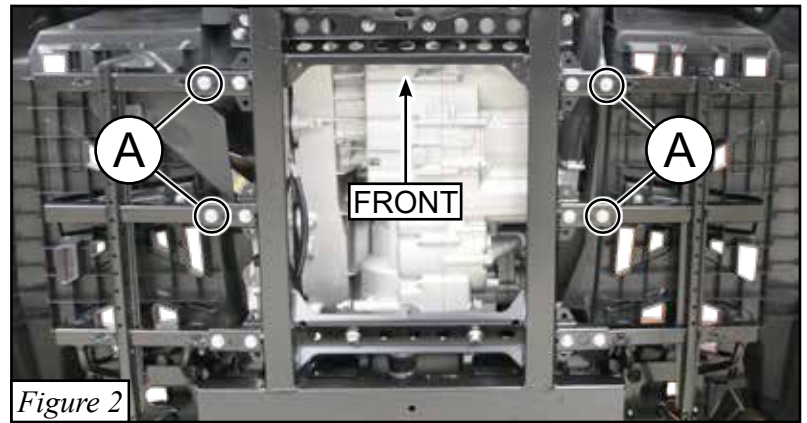

CFORCE 1000 INSTALLATION INSTRUCTIONS:

Note: Make sure all of the hardware needed to complete this mount is in the package (see figure 1 page 1). Read through and understand the instructions before installing.

1. Remove running board skid plates by removing hardware (B) on the running board frame tube shown in **Figure 5**. **NOTE:** Set skid plates and hardware aside as they will be reinstalled in a later step. Be sure to mark what side the skid plate came off of.
2. Remove the outer four bolts labeled (A) on the running board frame tube shown in **Figure 6**. **NOTE:** Middle skid plate is removed for clarity and will not need to be removed to install plow mount. Plow Mount (1) will be installed over top of the middle skid plate.
3. Place the plow mount (1) in its location lining up the bolt holes on the plow mount with the bolt holes from the four bolts (A) removed in step 2 as shown in **Figure 4**.
4. Secure plow mount (1) using M8 Hex Bolt (2.1), M8 Lock Washer (2.3) and M8 Flat Washer (2.4) as shown in **Figure 4**.
5. Keeping the running board skid plates on the same side as they were removed, spin both skid plated 180 degrees to allow clearance for plow mount (1) and reinstall as shown in **Figure 8**.
6. Tighten all hardware evenly.

